

ENERGYSAVER Direct Vent Wall Furnace

	<u>Natural Gas</u>	<u>Propane</u>
Rinnai model number:	RHFE-556FAIII-N	RHFE-556FAIII-P
Gas Rate (Input):	Btu/hr	Btu/hr
	Low: 8,200	8,200
	High: 21,500	20,700
Gas Rate (Output):	Low: 6,640	6,640
	High: 17,420	16,770
Efficiency Rating:	80.6%	84.2%
Gas Supply Pressure:	WC	WC
	Min: 5"	8.0"
	Max: 10.5"	13.0"
Description:	Fan forced flue gas furnace	
Connections:	Electrical – AC 120V 60Hz 52 watts Gas – 1/2" FNPT	
Combustion System:	Stainless steel Bunsen burner	
Ignition System:	Continuous spark	
Operating Buttons:	ON/OFF, Up/down, Child-Lock, Economy/Timers	
Economy Mode:	Energy savings feature	
Humidifier Tray:	Capacity - 3 pints (1300cc)	
Weight:	Approx. 51 lbs	
Clearance from Combustibles:	Side: 2" Top: 10" Front: 40"	
Dimensions:		

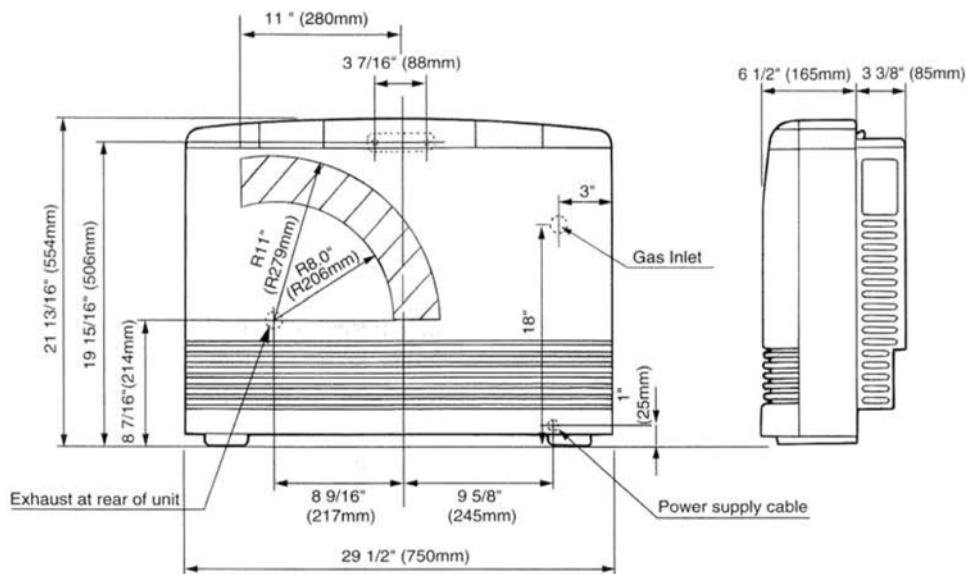

RHFE-556FAIII

Warm Air Outlet:	Bottom front louvers
Fan CFM Output:	Low: 110.5 High: 162.7
Operation:	Finger touch control buttons
Temperature Control:	Electronic thermostat HI-LOW/OFF, Up/Down switch 2°F increments
Temperature Range:	LOW=55°F 60°F~80°F HI=High Combustion
Safety Devices:	Flame failure – flame rod Over heat – Bi-metal switch, thermal fuse, thermistor Power failure - PCB Power surge – 3 Amp fuse Fan delay – Micro computer timer Pre-purge – Combustion fan, pre-purge timer, spark sensor Room over heat – Automatic cut off at 104°F after 10 minutes Child Safety Lock

Control Panel:

