





GENUINE SATELLITE RADIO KIT

INSTALLATION INSTRUCTIONS

Thank you for purchasing a genuine Mazda accessory.
Before removal and installation, be sure to thoroughly read these instructions.
Please read the contents of this booklet in order to properly install and use the satellite radio kit. Your safety depends on it.
Keep these instructions with your vehicle records for future reference.

WARNING

- There are several  **WARNING** and  **CAUTION** sections in this booklet concerning safety when installing. Always read and follow them in order to prevent injuries, accidents, and possible damage to the vehicle.
 -  **WARNING:** Indicates a situation in which serious injury or death could result if the warning is ignored.
 -  **CAUTION:** Indicates a situation in which bodily injury or damage to the vehicle could result if the caution is ignored.
- If in any doubt, please ask your Mazda dealer to install the accessory in order to prevent errors in installation.
- If you have any questions about the use of the accessory, ask your Mazda dealer for proper advice before using it.
- Mazda and its suppliers are not responsible for injuries, accidents, and damage to persons and property that arise from the failure of the dealer or installer to follow these instructions.
- To ensure safety and reliability of the work, installation, removal and disposal work done by an Authorized Mazda Dealership is recommended.
- Be careful not to lose removed parts, and be sure that they are kept free from scratches, grease or other dirt.

PART NAME: SATELLITE RADIO KIT
PART NUMBER: 0000 81 G01A
VEHICLE: MX-5 Miata, MPV, Tribute

NOTE

To the dealer

- Please turn over these instructions to the customer after installation.

To the customer

- Keep these instructions after installation. The instructions may be necessary for installing other optional parts or removal of this accessory.
- Should the vehicle or this accessory be resold, always leave these instructions with it for the next owner.

1ED6P11A06200A

1

INSTALLATION VIEW

MX-5 Miata

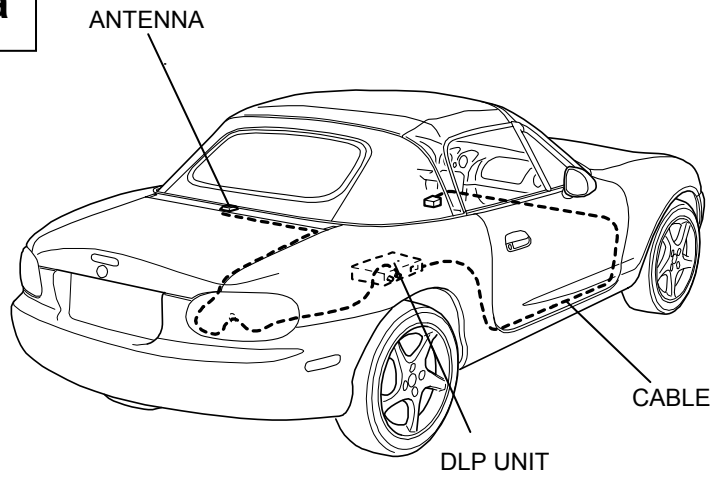

MPV

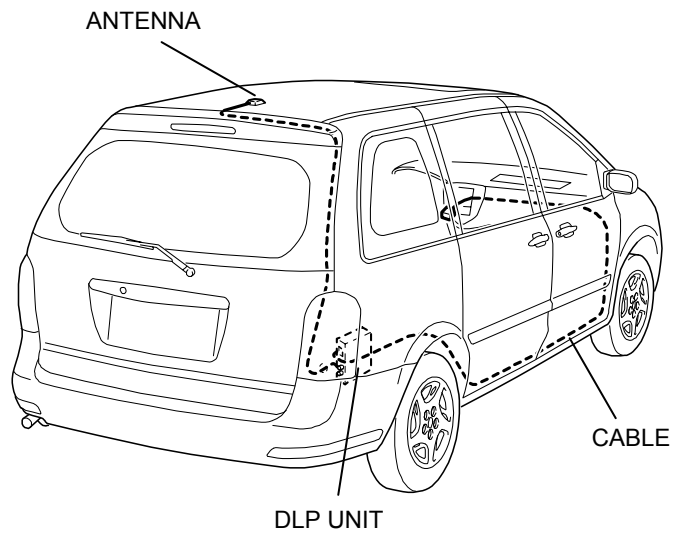



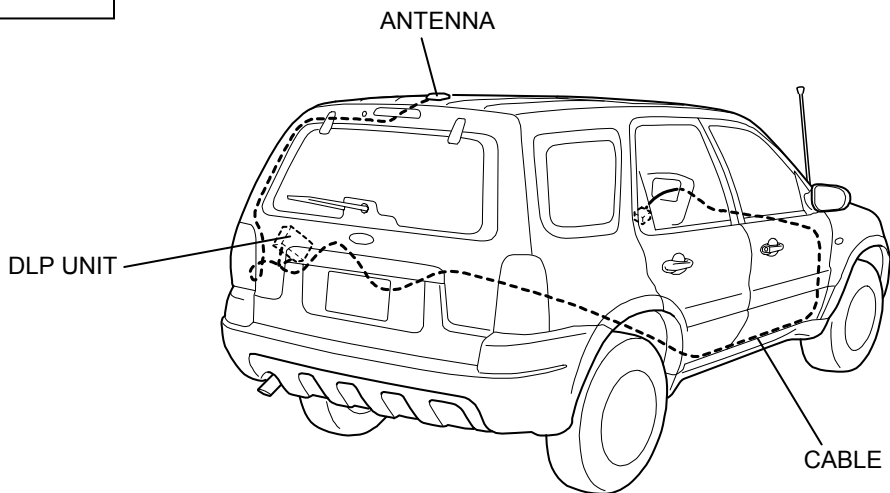







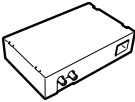
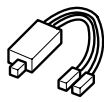
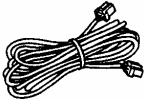

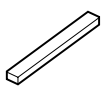
Tribute

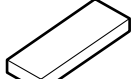

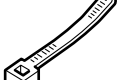
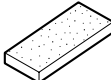
2 PARTS

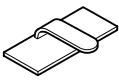
Note

- Verify that the kit includes all the following parts and that they are free of dirt, scratches or damage.

Part	Part name	Qty.	Part	Part name	Qty.	Part	Part name	Qty.
	Antenna 0000 81 Z02A	1		DLP unit 0000 81 Z01	1		Splitter 0000 81 Z13	1
	Cable	1		Antenna protector	1		Double-sided adhesive tape (For antenna protector)	1
	Double-sided adhesive tape (For antenna)	1		Double-sided adhesive tape (For splitter)	1		Double-sided adhesive tape	2
	Tie wrap	7		Tie wrap (Large)	6		Pad protector	9
	Butyl tape	1		Clip	1		Protector cushion	1
	Owner's Manual	1		Installation instructions	1			

3 BEFORE INSTALLATION

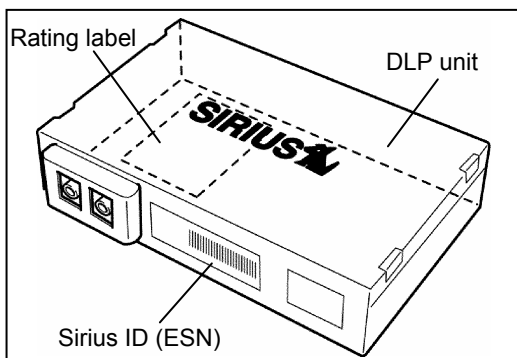

Rating Label Removal

1. Tear off lower part of the rating label on the bottom of DLP unit.
2. If there is nothing written in the Sirius ID (ESN) space of the rating label, write down the 12-digit number printed in the location shown in the figure.
3. Affix one rating label in the last page of the **Owner's Manual**.

Note

- The other rating label is for the dealer (port) records.
- Do not fail to submit the record.

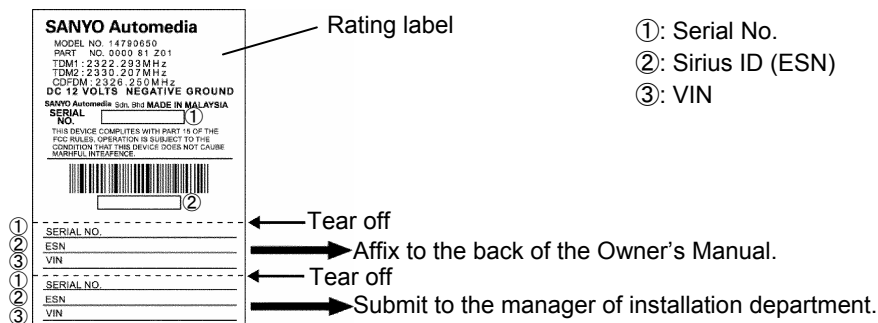



REQUIRED TOOLS

Prepare the following tools or items before installation.

- Electrical vinyl tape ● Mat ● Scissors ● Scale ● Touch-up paint or Zink primer ● Phillips screwdriver
- Socket driver (8 mm, 10 mm, 14 mm) ● File ● Fiber stick ● Wrench ● ISP alcohol

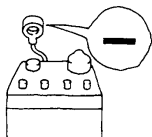
⚠ WARNING

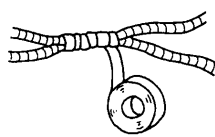
<p>When the negative battery cable is connected during operation, it may cause electric shock or other personal injuries. Disconnect the negative battery cable before removal/installation.</p>	<p>When connecting/disconnecting connectors, grasp the connectors, not the wires. Otherwise a short, an accident from poor contact or fire may occur.</p>	<p>Do not pull the harness with excessive force. Doing so can cause a breakage or a short-related accident, as well as an electrical short or fire.</p>	<p>Secure the harness with the band (part included) so it doesn't dangle. If not, it may cause a short, accident, or fire.</p>
			

⚠ CAUTION

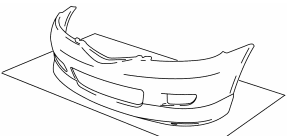
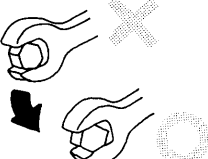
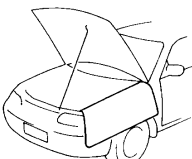
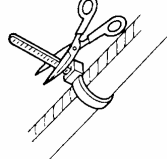
<p>Put the removed parts and the parts in the kit on the protective sheet to prevent scratches.</p>	<p>Using improper tools may cause damage and or broken parts. Use the correct tool for the job.</p>	<p>Be sure to cover the vehicle body with protectors or mats to prevent stains, scratches and damage when removing/installing the vehicle parts.</p>	<p>Excessive length of tie wrap may interfere with other parts and cause damage. Cut unnecessary part up to about 5 mm {0.19 in} from the fixed point.</p>
			

⚠ WARNING

- When removing/installing the parts, park the vehicle on level ground and apply the side brake securely. Be sure to turn the ignition switch off, otherwise the vehicle can move, causing personal injury or vehicle damage.

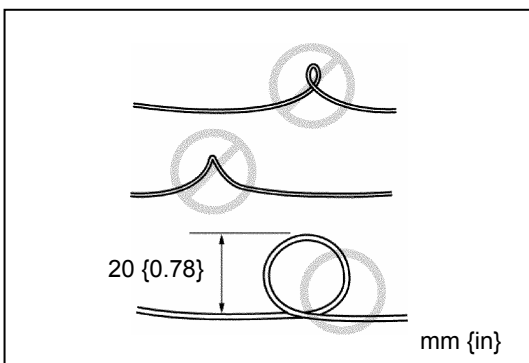

⚠ CAUTION

- During the installation of the antenna cable make sure the cable is not pinched, knotted "kinked" or coiled too tightly. It is recommended that a coil of less than 20 mm {0.78 in} be avoided if possible.
- If this wiring procedure is not followed, the performance of the antenna will be affected and could result in increased audio muting.

Note

- When the negative battery cable is removed, the clock, radio, trip meters and other memories will be erased. Before performing work, record the content of the memory.

4 PART REMOVAL

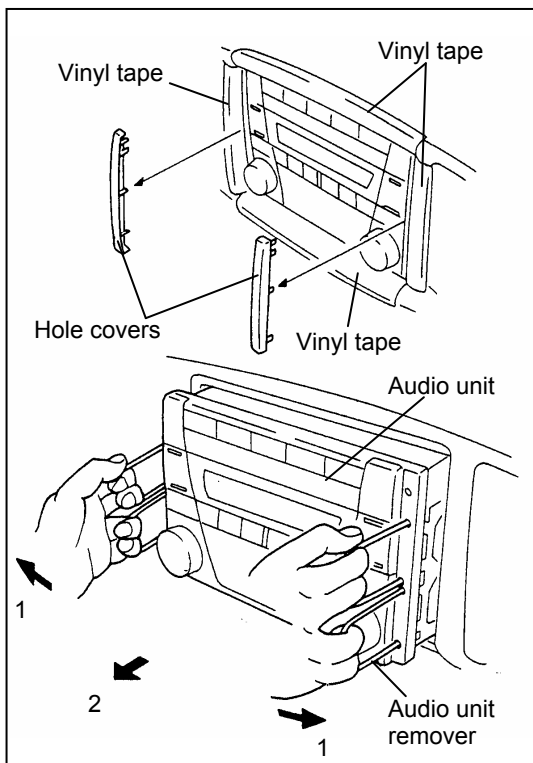

⚠ CAUTION

- Be careful not to damage or lose removed parts during removal.

Audio Unit removal

⚠ CAUTION

- Attach vinyl tape to the entire area of the center panel surrounding the audio unit to prevent scratches while working.

1. Remove the hole covers from the audio unit by using a protected screwdriver or a fiber stick.
2. Insert the audio removal tools and spread both sides outward while slowly pulling the audio unit outward.
3. Disconnect the connector and the one antenna feeder plug.

⚠ CAUTION

- Do not pull on the wiring harness.

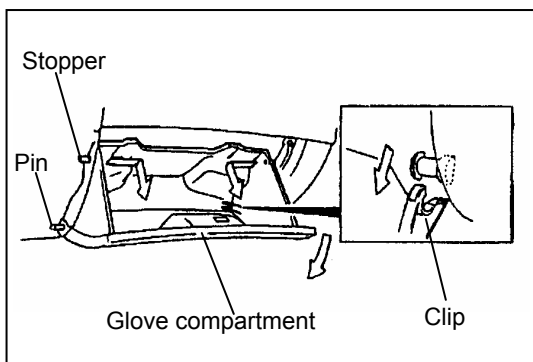

Glove compartment removal

1. Bend the stoppers inward, then remove.
2. Turn the glove compartment downward and pull the clip.
3. Slide the glove compartment to the right, then disengage the pin.

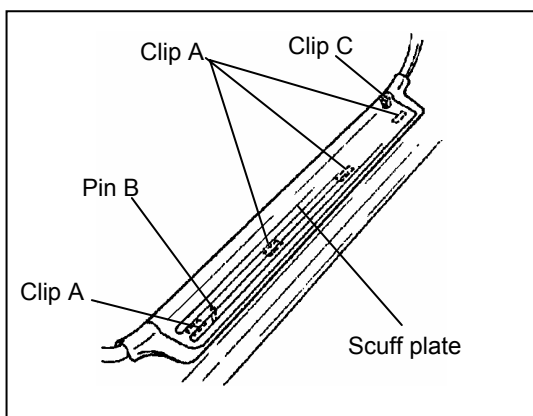

⚠ CAUTION

- Be careful not to damage the scuff plate during removal.

Scuff plate (passenger's side) removal

1. Pull the scuff plate upward by using a fiber stick, then disengage clips A, C and pin B from the body.

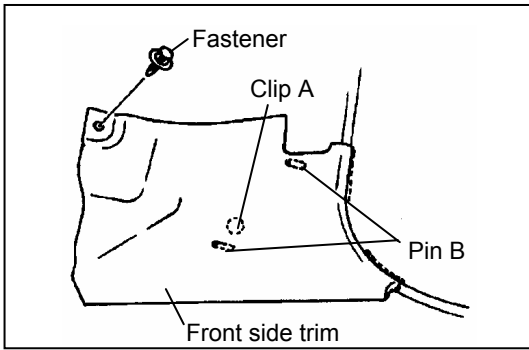

Front side trim (passenger's side) removal

1. Remove the fastener.
2. Pull the front side trim toward you, then disengage clip A, and pins B from the body.

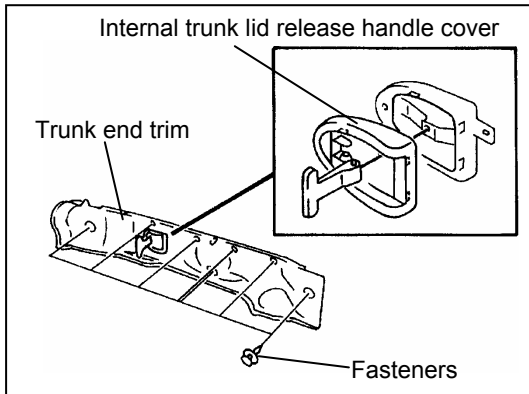

Trunk end trim removal

1. Remove internal trunk lid release handle cover.
2. Remove the fasteners.
3. Remove the trunk end trim.

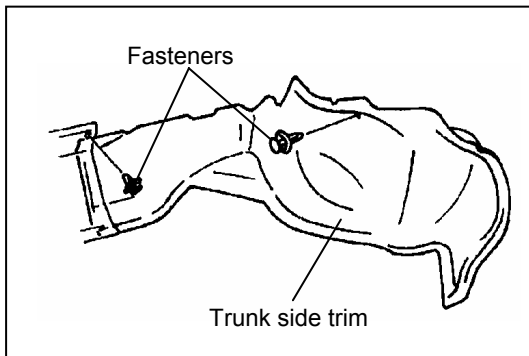

Trunk side trim (passenger's side) removal

1. Remove the fasteners.
2. Remove the trunk side trim.

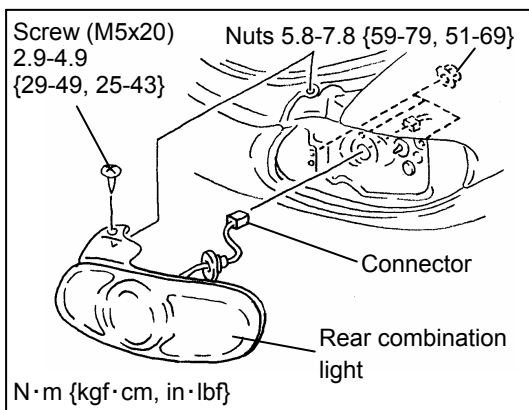

Rear combination light (passenger's side) removal

1. Disconnect the connector.
2. Remove the screw.
3. Remove the two nuts (10 mm).
4. Remove the rear combination light.

5

INSTALLING ANTENNA

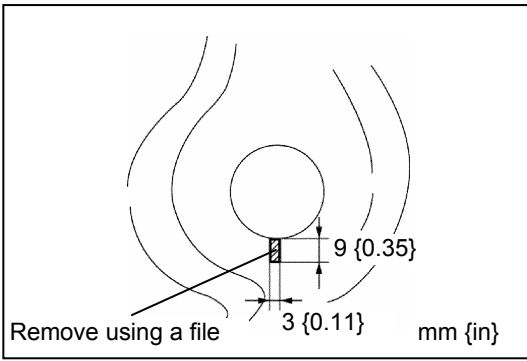

1. File the hole where the rear combination light wiring harness passes through as shown in the figure.

⚠ CAUTION

- When filing, always use a mat or other protection to prevent shavings from getting into the vehicle interior.
- Be sure to remove any burrs after filing.
- Remove any chips or drill filings that may have fallen in the vehicle.

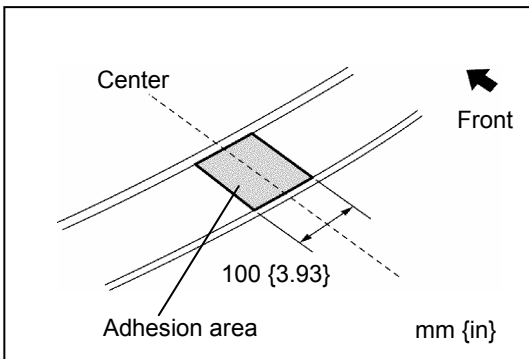

2. Using ISP alcohol, remove grease from around the holes and apply touch-up paint or zinc primer for rust prevention.

3. Clean the adhesion area on the trunk lid with ISP alcohol.

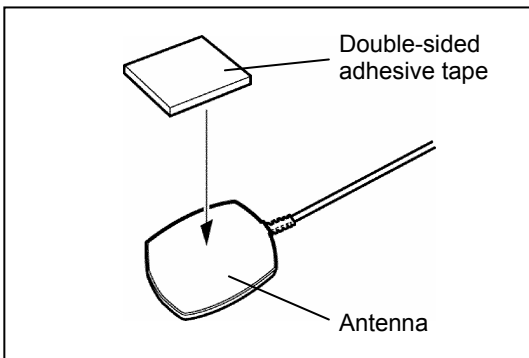

4. Affix the double-sided adhesive tape to the antenna.

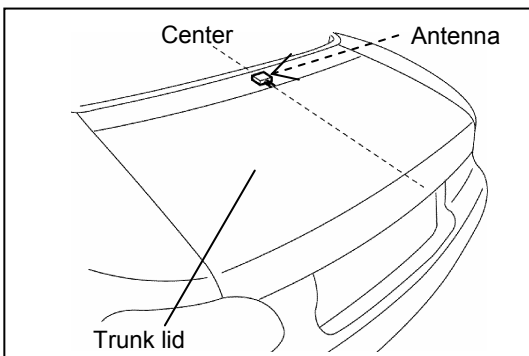

5. Install the antenna in the position shown in the figure. (Refer to Step 6 for the antenna installation position.)

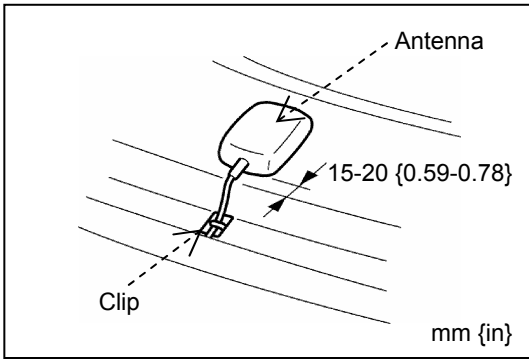

6. Clean the adhesion area of the clip with ISP alcohol.
7. Attach the clip to the vehicle as shown in the figure.
8. Install the antenna cable to the clip.

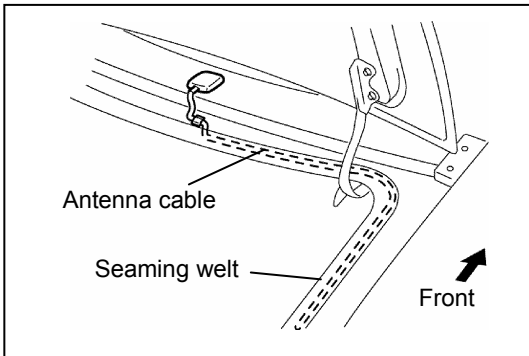

9. Pull the seam upward and route the antenna cable in seaming welt. (Does not need to be completely removed)

CAUTION

- Be careful not to tear the seaming welt when pulling it out.

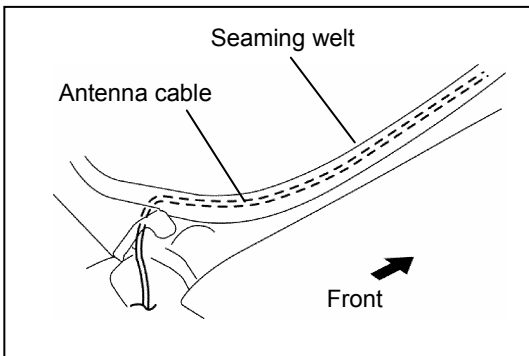

10. Return the seaming welt to its original position.

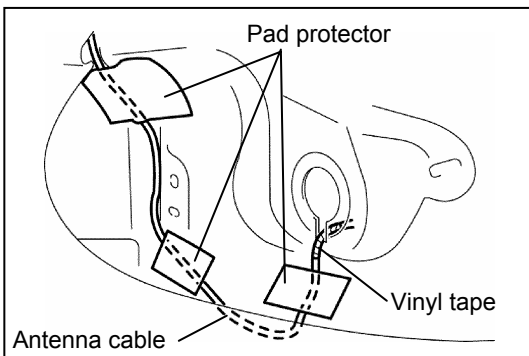

11. Clean the adhesion area with ISP alcohol.
12. Secure the antenna cable in place with pad protector halves.
13. **Route the antenna cable into the trunk compartment with the vinyl taped portion in the filed-out part of hole.**

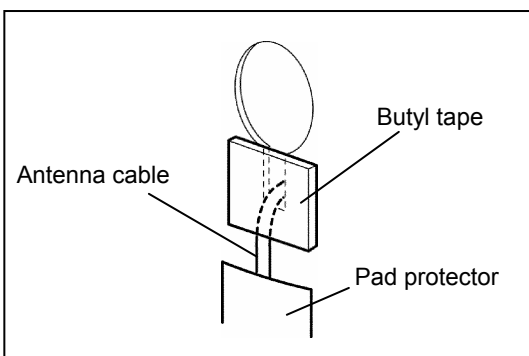

14. Affix butyl tape in the position shown in the figure.

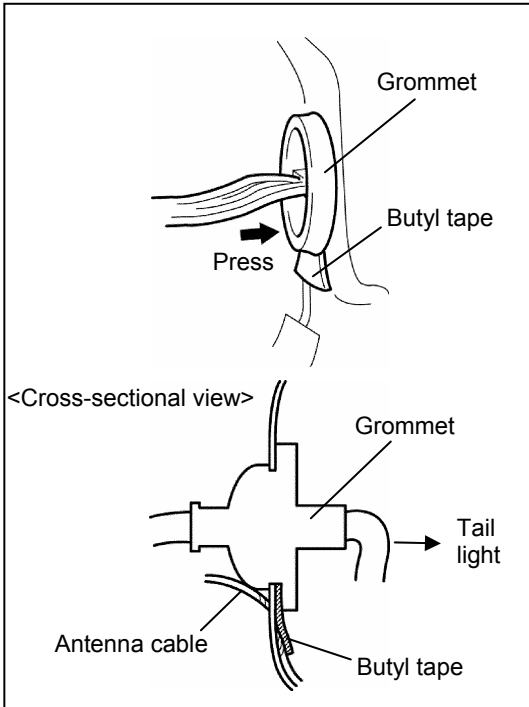

15. Install the rear combination light grommet.

CAUTION

- Press the rear combination light grommet firmly against the butyl tape when installing.

16. Install the rear combination light.

Tightening Torque

Nuts: 5.8-7.8 N·m {59-79 kgf·cm, 51-69 in·lbf}

Screw: 2.9-4.9 N·m {29-49 kgf·cm, 25-43 in·lbf}

17. Reconnect the rear combination light connector.

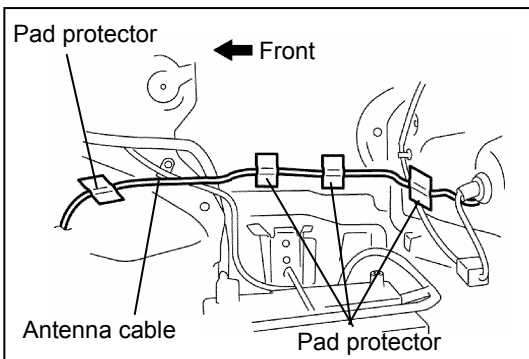

18. Clean the adhesion area with ISP alcohol.

19. Secure the antenna cable with pad protector halves.

6 INSTALLING THE CABLE

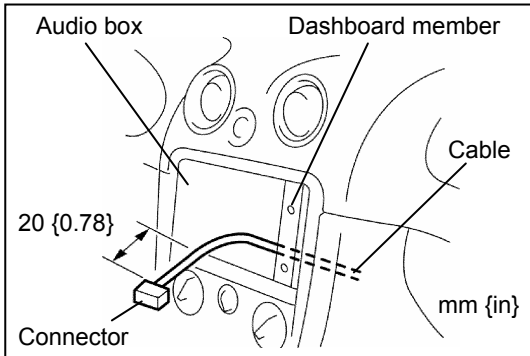

1. Route the cable through the back of the dashboard member.
2. Pull the 16-pin connector (white) 20 mm {0.78 in} out from the audio box.

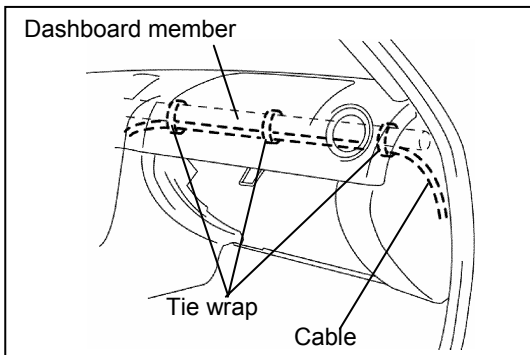

3. Secure the cable in the glove compartment to the dashboard member with the tie wrap and adjust the length of the tie wrap to avoid the interference with glove compartment.

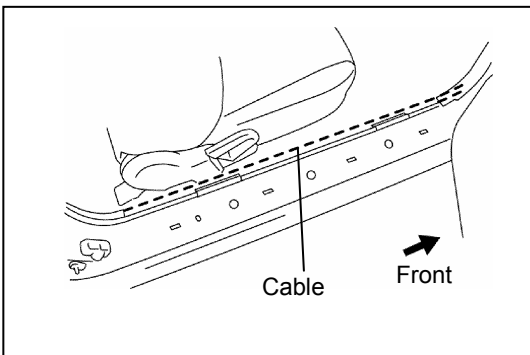

4. Run the cable inside the scuff plate along the vehicle harness and pass it through the center of the floor covering.

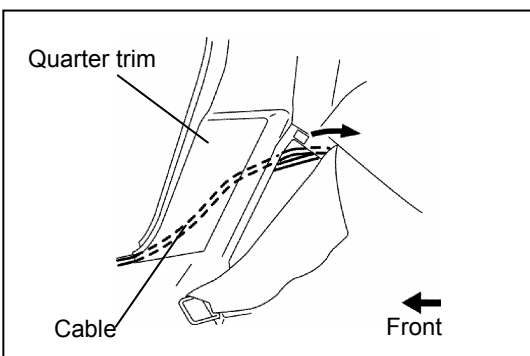

5. Route the cable behind the quarter trim and to the trunk compartment by peeling back the seaming welt and releasing the bottom 2 clips of the quarter trim.

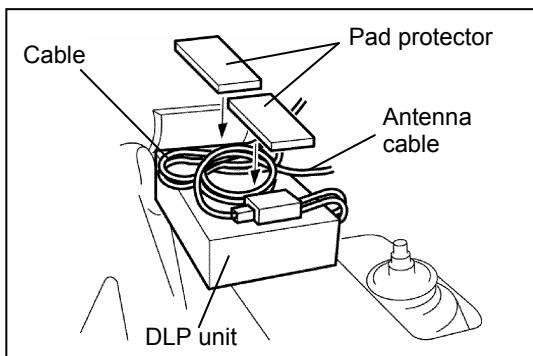
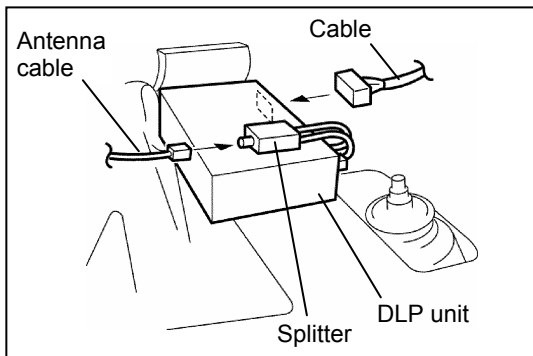
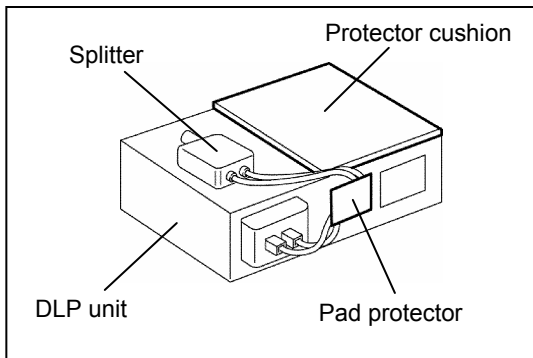
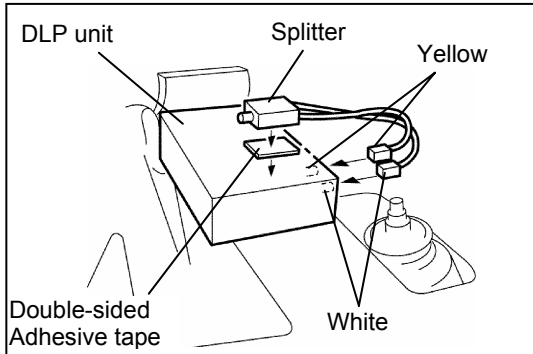
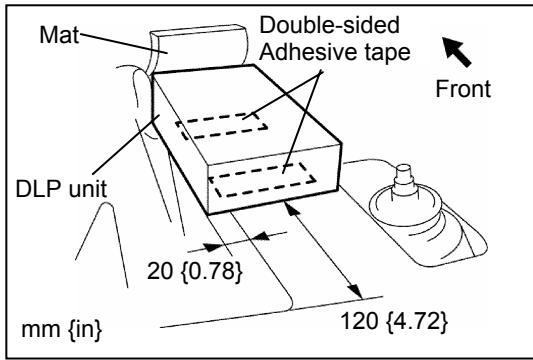

6. Peel back the mat and clean the adhesion area with ISP alcohol.
7. Install the DLP unit with double-sided adhesive tape in the far right-rear side of the trunk compartment.

Note

- Cut off any excess double-sided adhesive tape from DLP unit.

8. Connect the splitter connector to the DLP unit.
9. Affix the splitter to the top of the DLP unit with double-sided adhesive tape.

10. Cut the protector cushion and affix it to the top of the DLP unit.

11. Secure the splitter cables with the pad protector halves.

12. Connect the antenna cable connector (black) to the DLP unit.

13. Connect the antenna cable connector to the splitter.

14. Bundle the antenna and regular cables, and secure them to the top of the DLP unit with a pad protector.

CAUTION

- Be sure to bundle the antenna cable into a loop.

Note

- After completing the installation, refer to the owner's manual for instructions on how to reset the clock and preset radio stations, and record the trip meter numbers on the check sheet.

7 REINSTALLATION OF VEHICLE PARTS

- Install in the reverse order of “Part removal”.



CAUTION

- After installing the vehicle parts, check for dirt. Clean any dirty parts.
-
- Perform the Inspection indicated on the last page of these installation instructions.

8 PART REMOVAL

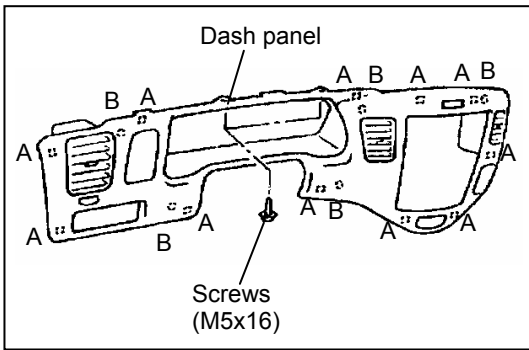

CAUTION

- Be careful not to damage or lose removed parts during removal.

Dash panel removal

1. Remove the two screws using a Phillips screwdriver.
2. Pull the dash panel toward you, insert the fiber stick into point A and B then disengage clip A, and pins B from the dashboard, and remove the dash panel.

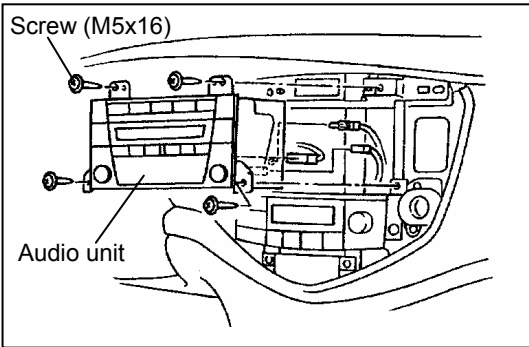

Audio unit removal

1. Remove the four screws using a Phillips screwdriver.
2. Disconnect the connector and the antenna feeder plug.

CAUTION

- Do not pull on the wiring harness.

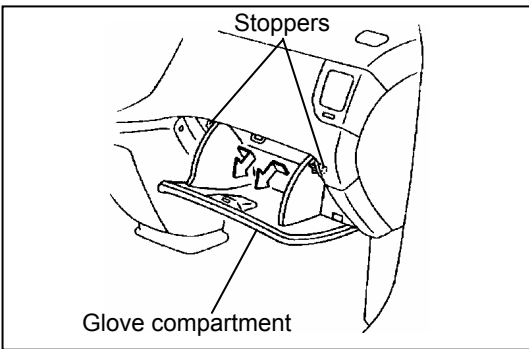

Glove compartment removal

1. Bend the stoppers inward to loosen the top portion.

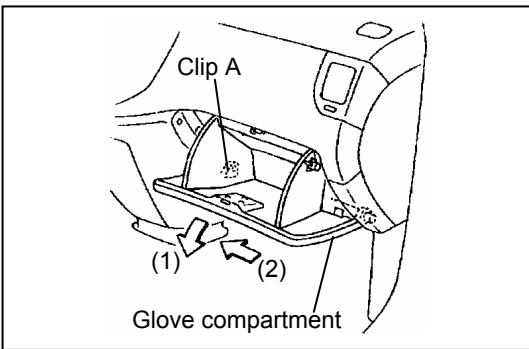

2. Pull the glove compartment outward while pushing it downward (1), to free clip A
3. To remove the glove compartment slide it toward the driver's side door (2).

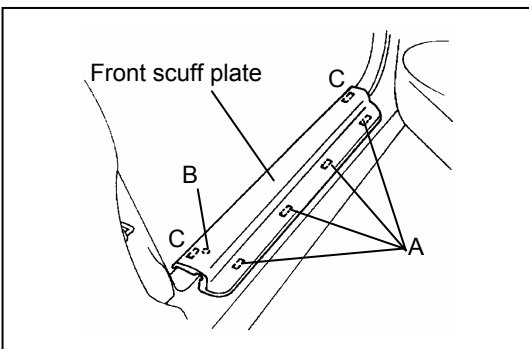

CAUTION

- Be careful not to damage the scuff plate during removal.

Front scuff plate (passenger's side) removal

1. Pull the front scuff plate upward using a fiber stick, then disengage clips A, pin B and hooks C from the body, and remove the front scuff plate.

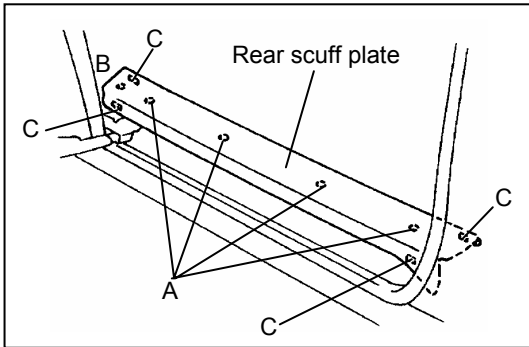

Rear scuff plate (passenger's side) removal

1. Pull the rear scuff plate upward by using a fiber stick, then disengage clips A, pin B and hooks C from the body, and remove the rear scuff plate.

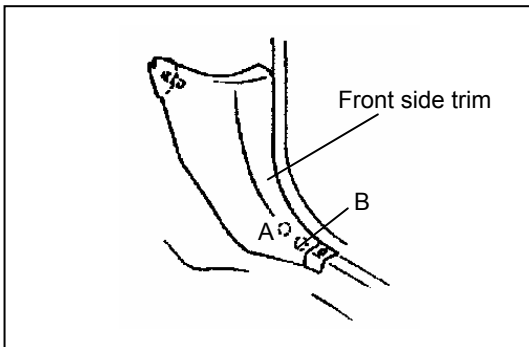

Front side trim (passenger's side) removal

1. Turn the rubber seaming welt over.
2. Pull the front side trim inboard, then disengage clip A and pin B from the body, and remove the front side trim.

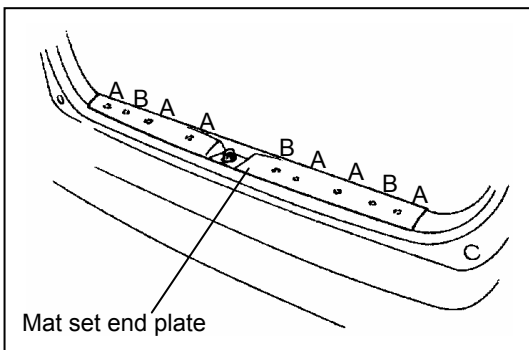

Mat set end plate removal

1. Turn the seaming welt over. (Does not need to be completely removed)

⚠ CAUTION

- Be careful not to tear the seaming welt when pulling it out.

2. Disengage clips A and pins B using a fiber stick, and remove the mat set end plate.

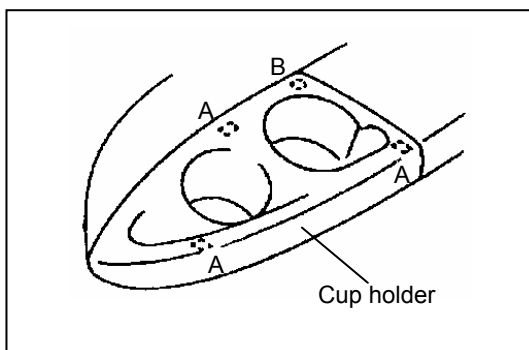

Rear cup holder removal

1. Pull the cup holder upward, then disengage clips A and pin B from the rear side trim, and remove the cup holder.

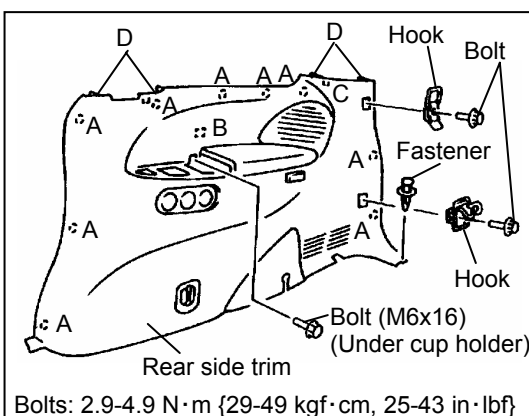

Rear side trim (passenger's side) removal

1. Remove the bolts using a socket driver (8 mm) and one fastener.
2. Pull the rear side trim outward, then disengage clip A, pin D, tabs C and D from the body.

Bolts: 2.9-4.9 N·m {29-49 kgf·cm, 25-43 in·lbf}

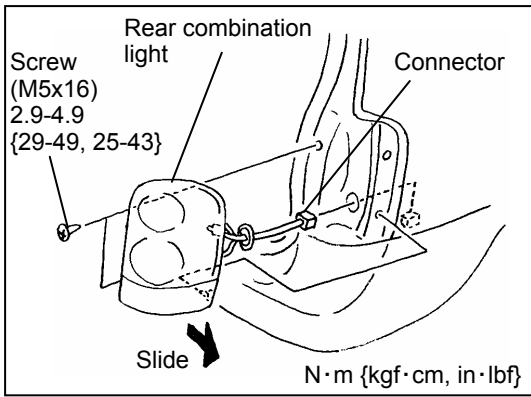

Rear combination light (passenger's side) removal

1. Disconnect the connector.
2. Remove the two screws.
3. Slide the rear combination light outward from the vehicle and disengage the attachment pins.
4. Remove the rear combination light.

9

INSTALLING ANTENNA

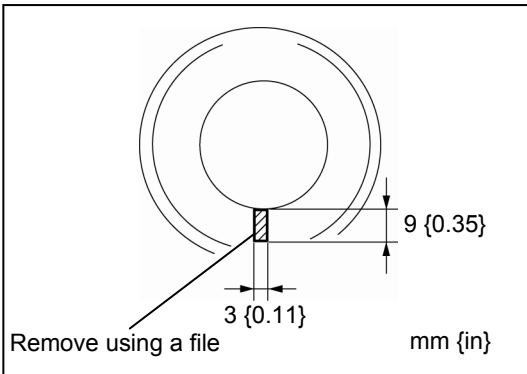

1. File the hole where the rear combination light harness passes through as shown in the figure.

⚠ CAUTION

- When filing, always use a mat or other protection to prevent shavings from getting into the vehicle interior.
- Be sure to remove any burrs after filing.
- Remove any chips or drill filings that may have fallen in the vehicle.

2. Using ISP alcohol, remove grease from around the holes and apply touch-up paint or zinc primer for rust prevention.

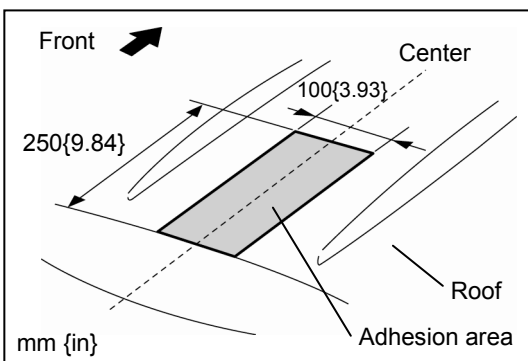

3. Clean the adhesion area on the trunk lid with ISP alcohol.

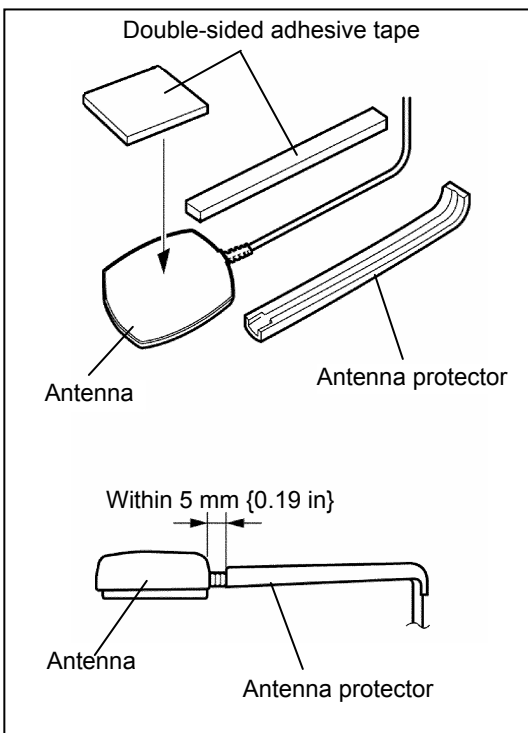

4. Install the antenna protector to the antenna and affix the double-sided adhesive tape.
5. Affix the double-sided adhesive tape to the antenna.

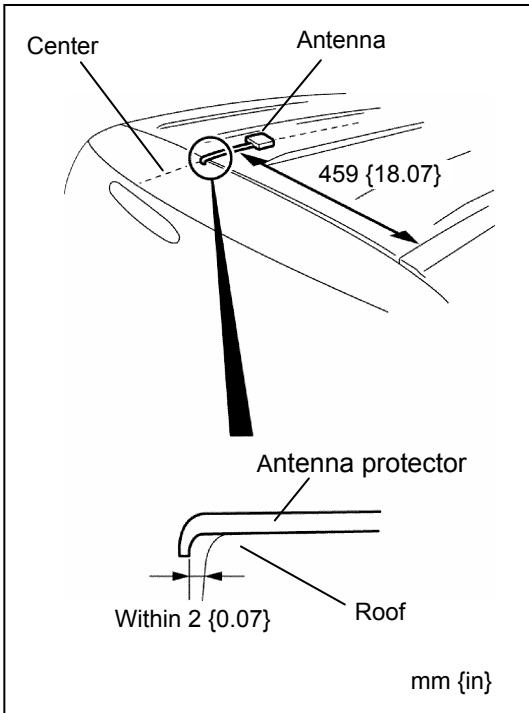

6. Install the antenna in the position shown in the figure from the edge of the roof panel.

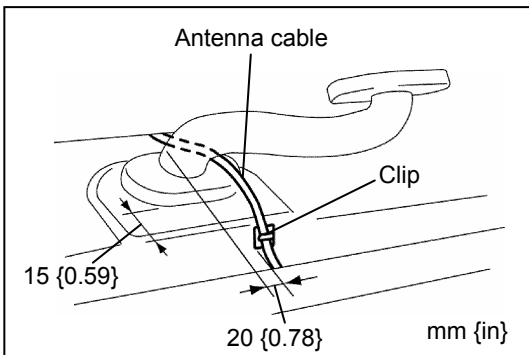

7. Clean the adhesion area of the clip with ISP alcohol.
8. Attach the clip to the vehicle as shown in the figure.
9. Install the antenna cable to the clip.

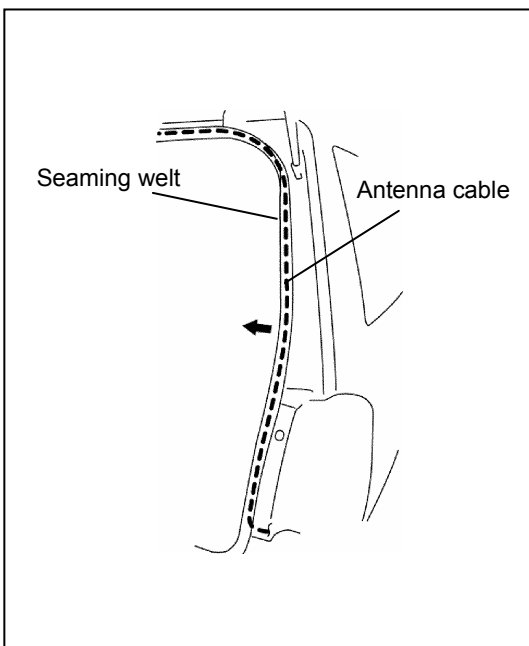

10. Pull seam upward and route the antenna cable in the seaming welt. (Does not need to be completely removed)

CAUTION

- Be careful not to tear the seaming welt when pulling it out.

11. Reinstall the rubber seaming welt to its original position.

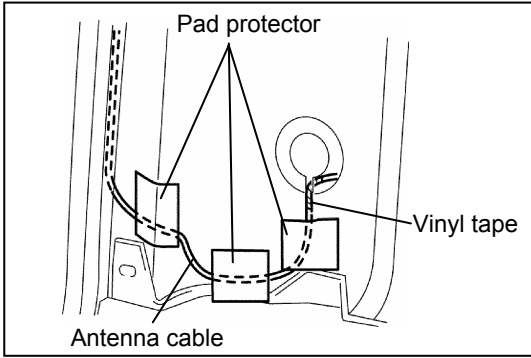

12. Clean the adhesion area with ISP alcohol.
13. Secure the antenna cable in place with pad protector halves.
14. **Route the antenna cable into the trunk compartment with the vinyl taped portion in the filed-out part of hole.**

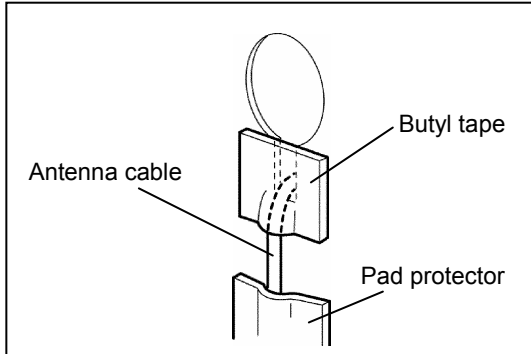

15. Affix butyl tape in the position shown in the figure.

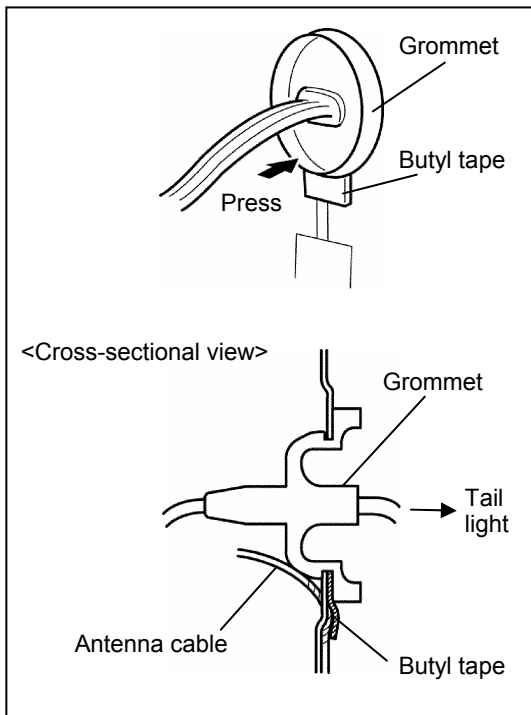

16. Install the rear combination light grommet.

CAUTION

- Press the rear combination light grommet firmly against the butyl tape when installing.

17. Install the rear combination light.
18. Reconnect the rear combination light connector.

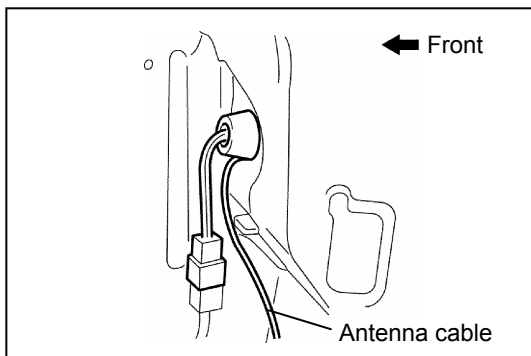

19. Route the antenna cable as shown in the figure.

10 INSTALLING THE CABLE

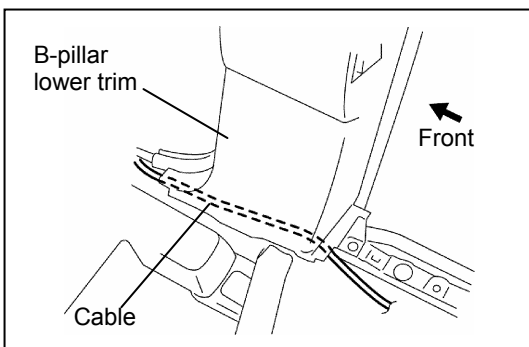
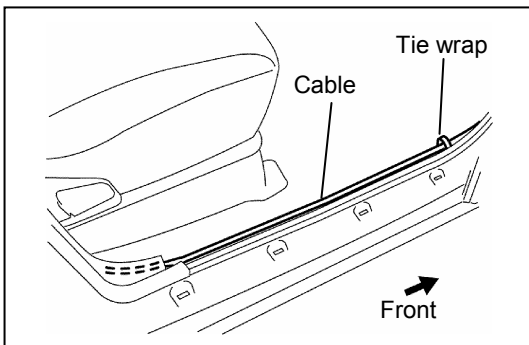
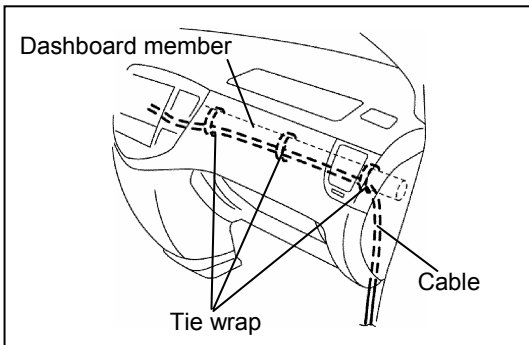
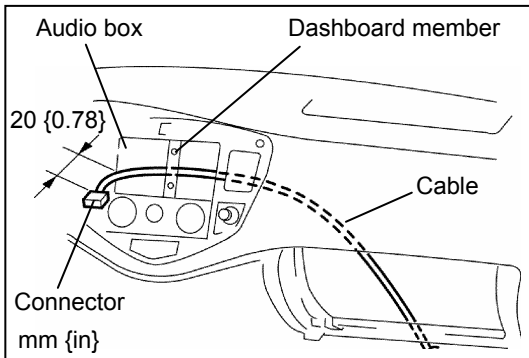

1. Route the cable through the back of the dashboard member.
2. Feed the 16-pin connector (white) 20 mm {0.78 in} to the audio box from the glove compartment.
3. Secure the cable in the glove compartment to the dashboard member with three tie wraps. Confirm the clearance with the glove compartment.
4. Run the cable inside the front scuff plate along the vehicle harness and pass it through the center of the floor covering.
5. Secure the cable to the vehicle harness with a tie wrap.
6. Insert the cable under the B-pillar trim.

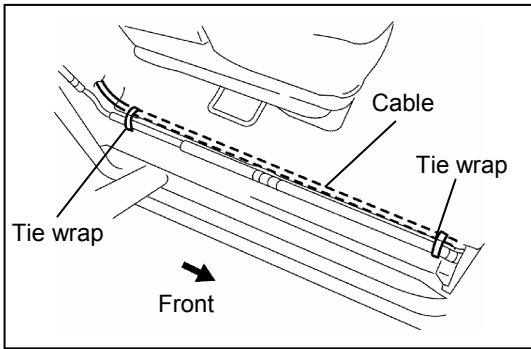

7. Run the cable inside the rear scuff plate along the vehicle harness and pass it through the center of the floor covering.
8. Secure the cable to the vehicle harness with a tie wrap.

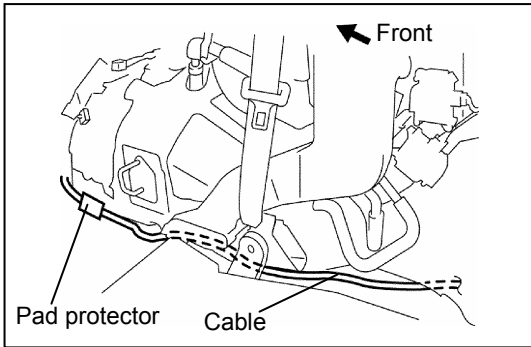

9. Route the cable through the inside of the rear side trim and fix in place with a pad protector halves.

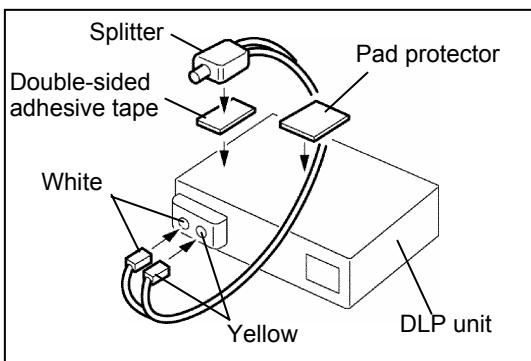

10. Connect the splitter connector to the DLP unit.
11. Affix double-sided adhesive tape to the splitter.
12. Affix the splitter to the top of the DLP unit with double-sided adhesive tape.
13. Secure the splitter cables with pad protector halves.

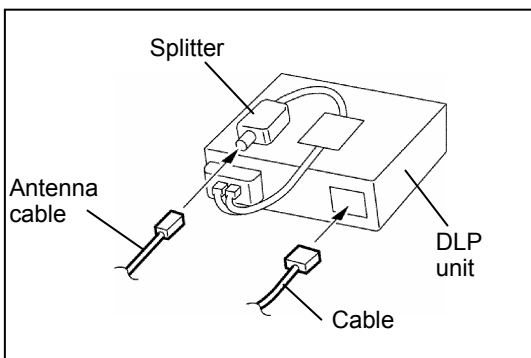

14. Connect the antenna cable connector to the splitter and the cable connector (black) to the DLP unit.

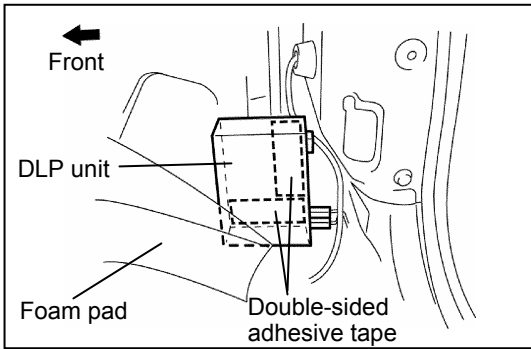

15. Clean the adhesion area with ISP alcohol.
16. Slightly peel back the foam pad inside the rear side trim and secure the DLP unit with the double-sided adhesive tape.

Note

- Cut off any excess double-sided adhesive tape from DLP unit.

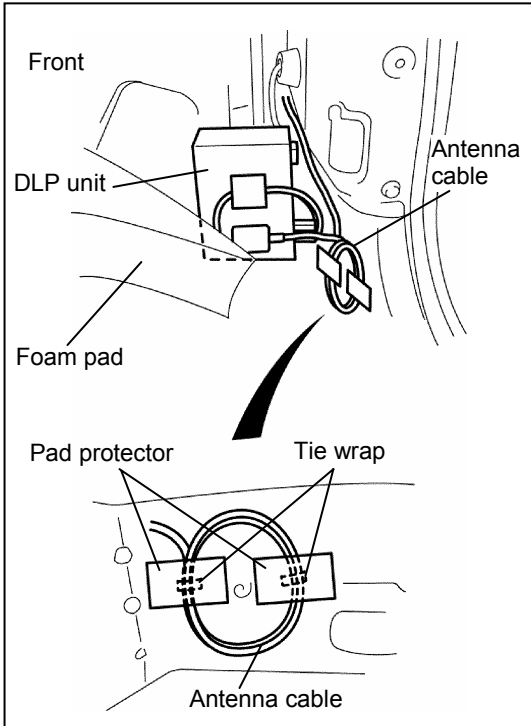

17. Bundle up the antenna cable into a loop using the tie wrap, and secure it to the vehicle panel with the pad protector.

CAUTION

- Be sure to bundle the antenna cable into a loop.

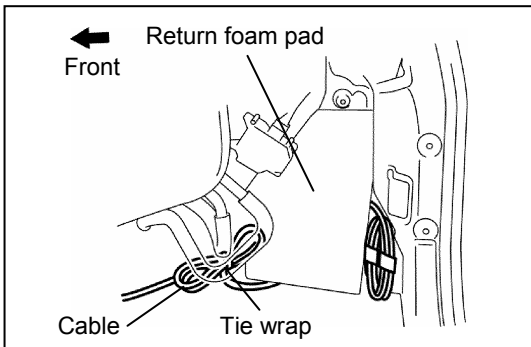

18. Return the foam pad to its original position.

Note

- After completing the installation, refer to the owner's manual for instructions on how to reset the clock and preset radio stations, and record the trip meter numbers on the check sheet.

11 REINSTALLATION OF VEHICLE PARTS

- Install in the reverse order of "Part removal".

CAUTION

- After installing the vehicle parts, check for dirt. Clean any dirty parts.

- Perform the Inspection indicated on the last page of these installation instructions.

12 PART REMOVAL

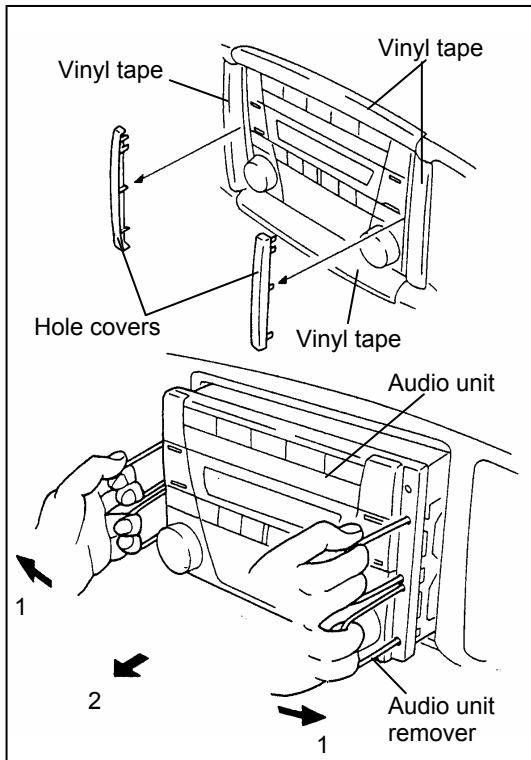

CAUTION

- Be careful not to damage or lose removed parts during removal.

Audio Unit removal

CAUTION

- Attach vinyl tape to the entire area of the center panel surrounding the audio unit to prevent scratches while working.

1. Remove the hole covers from the audio unit by using a protected screwdriver or a fiber stick.
2. Insert the audio removal tools and spread both sides outward while slowly pulling the audio unit outward.
3. Disconnect the connector and the one antenna feeder plug.

CAUTION

- Do not pull on the wiring harness.

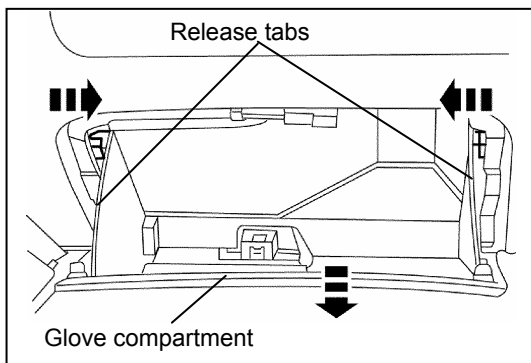

Glove compartment removal

1. Open the glove compartment, press the release tabs inward, and pull the glove compartment outward to remove.

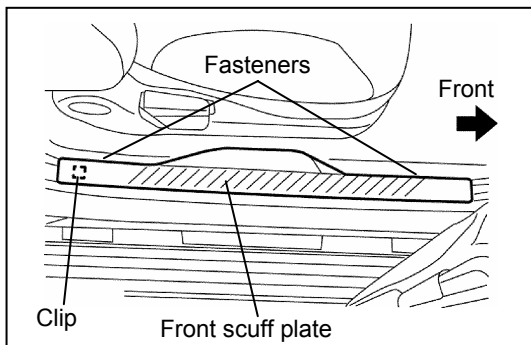

CAUTION

- Be careful not to damage the scuff plate during removal.

Front scuff plate (passenger's side) removal

1. Remove the two fasteners.
2. Pull the front scuff plate upward using a fiber stick, then the disengage clip from body, and remove the front scuff plate.

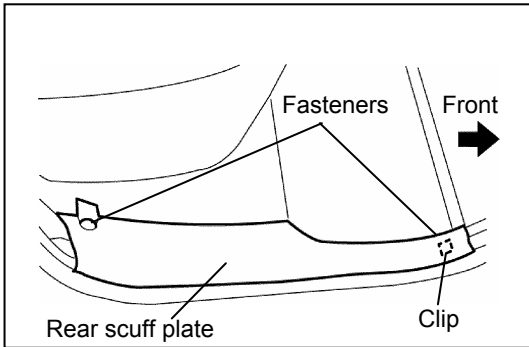

Rear scuff plate removal

Note

- The figure shows the passenger's side, however, the removal for the driver's side is the same.

1. Remove the two fasteners.
2. Pull the rear scuff plate upward by using a fiber stick, then disengage clip from the body, and remove the rear scuff plate.

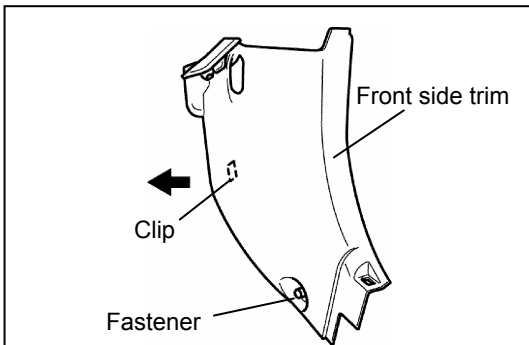

Front side trim (passenger's side) removal

1. Turn the rubber seaming welt over.
2. Remove the fastener.
3. Detach the clips by pulling the front side trim toward the driver's side to remove the front side trim.

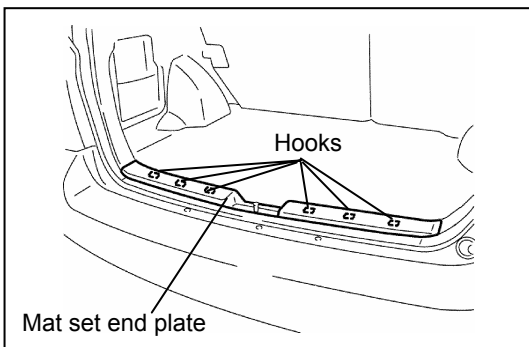

Mat set end plate removal

1. Disengage the hooks using a fiber stick, and remove the mat set end plate.

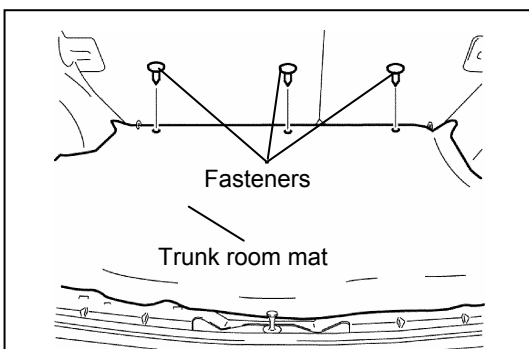

Trunk room mat removal

1. Remove the three fasteners, then remove the trunk room mat.

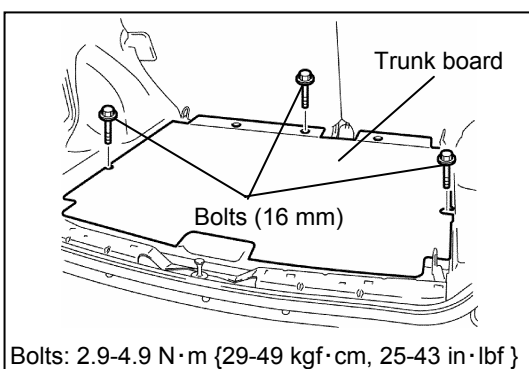

Trunk board removal

1. Remove the three bolts, then remove the trunk board.

Bolts: 2.9-4.9 N·m {29-49 kgf·cm, 25-43 in·lbf }

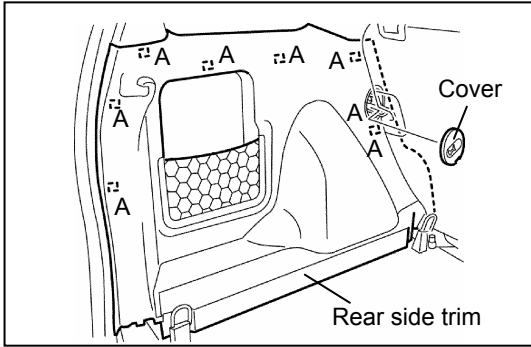

Rear side trim (driver's side) removal

1. Remove the cover.
2. Pull the rear side trim toward you, then disengage clip A, from the body.

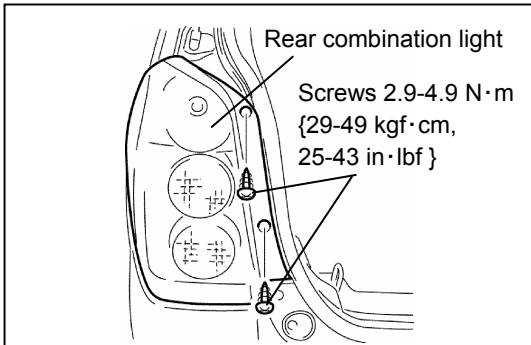

Rear combination light (driver's side) removal

1. Disconnect the connector.
2. Remove the two screws.
3. Pull the rear combination light rearward to disconnect the pins.
4. Remove the rear combination light.

13 INSTALLING ANTENNA

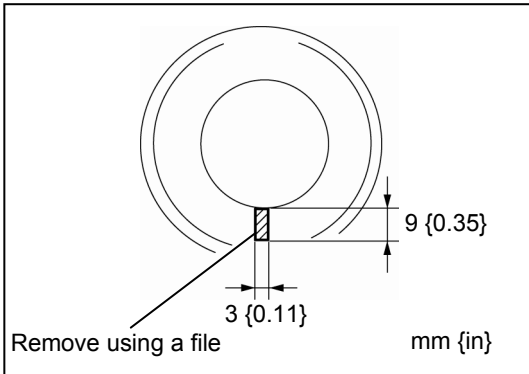

1. File the hole where the rear combination light harness passes through as shown in the figure.

⚠ CAUTION

- When filing, always use a mat or other protection to prevent shavings from getting into the vehicle interior.
- Be sure to remove any burrs after filing.
- Remove any chips or drill filings that may have fallen in the vehicle.

2. Using ISP alcohol, remove grease from around the holes and apply touch-up paint or zinc primer for rust prevention.

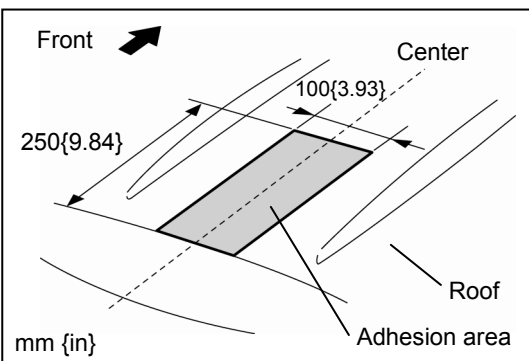

3. Clean the adhesion area on the trunk lid with ISP alcohol.

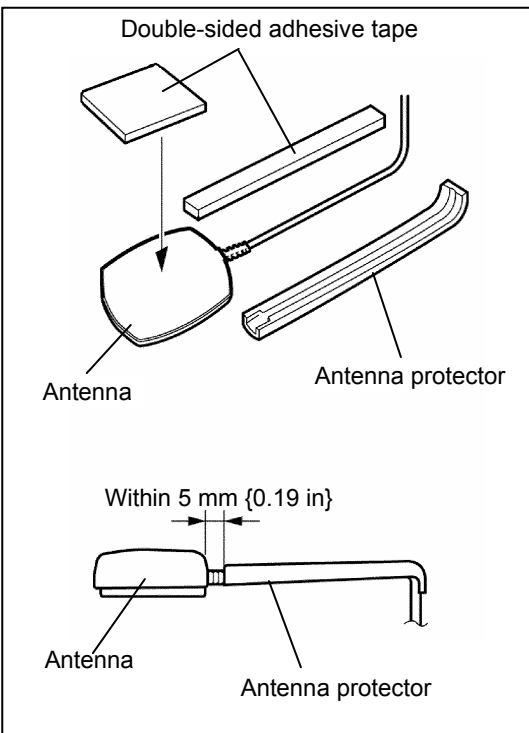

4. Install the antenna protector to the antenna and affix the double-sided adhesive tape.
5. Affix the double-sided adhesive tape to the antenna.

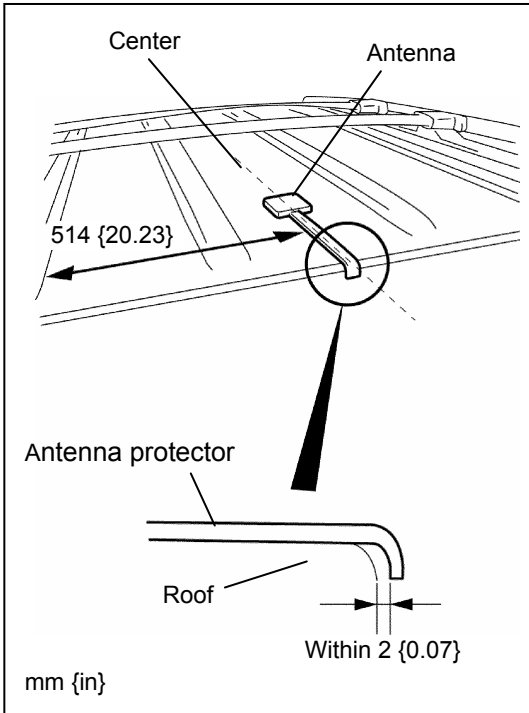

6. Install the antenna in the position shown in the figure.

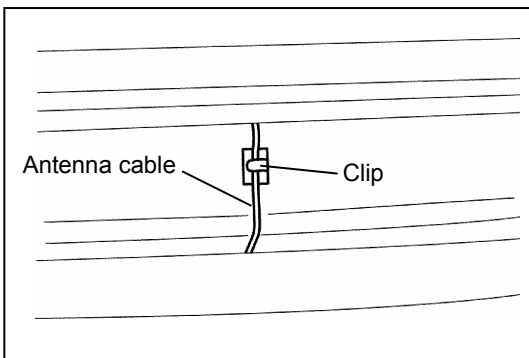

7. Clean the adhesion area of clip with ISP alcohol.

8. Attach the clip to vehicle as shown in the figure.

9. Install the antenna cable to the clip.

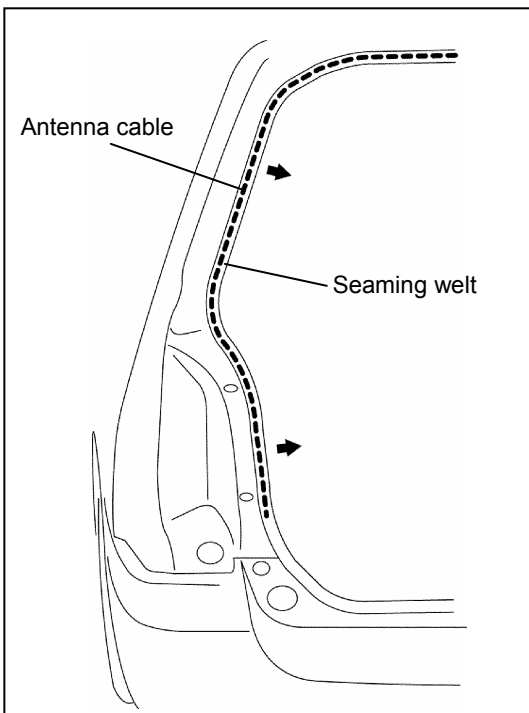

10. Pull the seam upward and route the antenna cable in the seaming welt. (Does not need to be completely removed)

CAUTION

- Be careful not to tear the seaming welt when pulling it out.

11. Reinstall the rubber seaming welt to its original position.

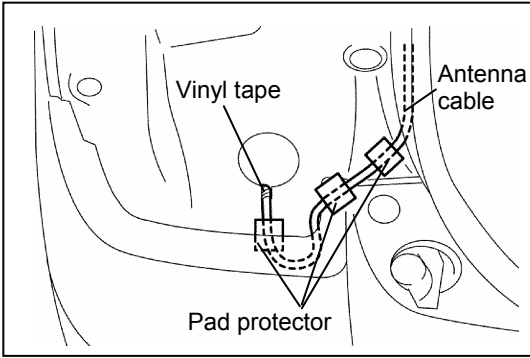

12. Clean the adhesion area with ISP alcohol
13. Secure the antenna cable in place with pad protector halves.
14. **Route the antenna cable into the trunk compartment with the vinyl taped portion in the filed-out part of hole.**

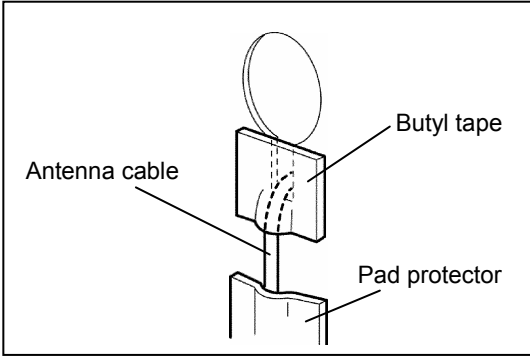

15. Affix butyl tape in the position shown in the figure.

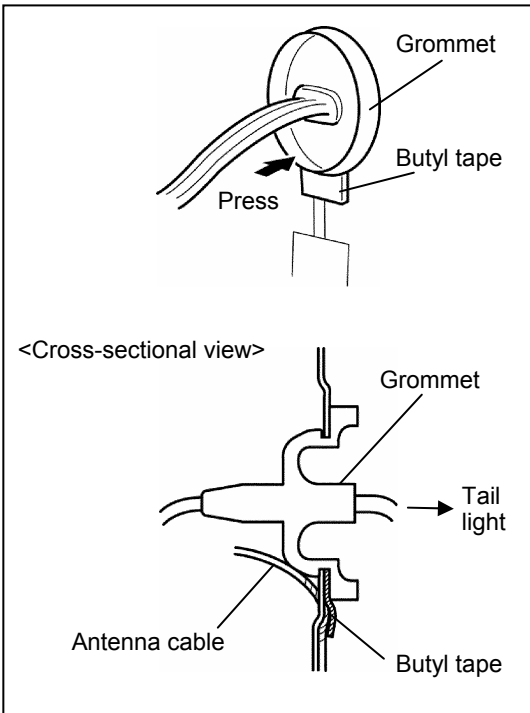

16. Install the rear combination light grommet.

CAUTION

- Press the rear combination light grommet firmly against the butyl tape when installing.

17. Install the rear combination light.
18. Reconnect the rear combination light connector.

14 INSTALLING THE CABLE

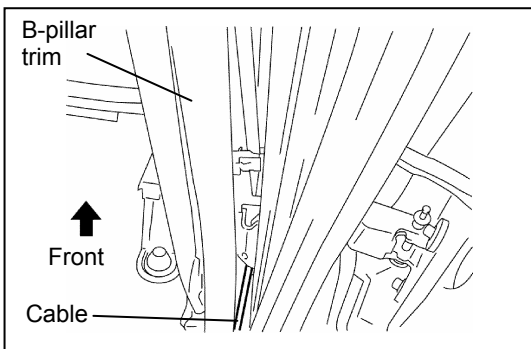
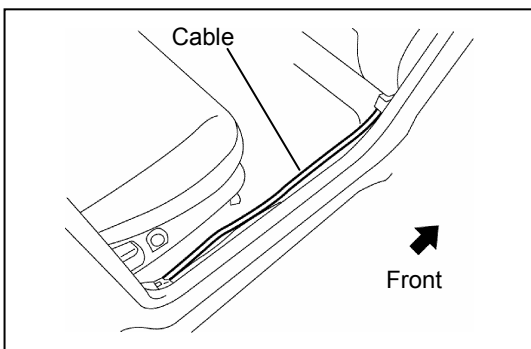
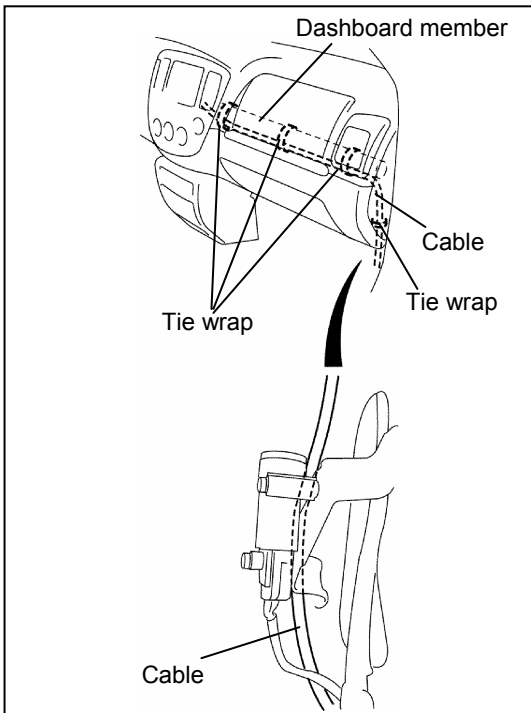
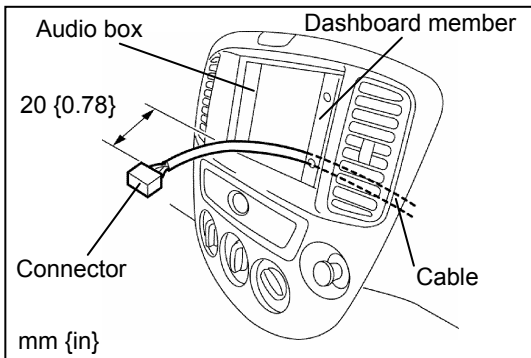

1. Route the cable through the back of the dashboard member.

2. Feed the 16-pin connector (white) 20 mm {0.78 in} to the audio box from glove compartment.

3. Secure the cable in the glove compartment to the dashboard member with three tie wraps. Confirm the clearance with glove compartment.

4. Run the cable inside the front scuff plate along the vehicle harness.

5. Partially remove the B-pillar trim, then route the cable.

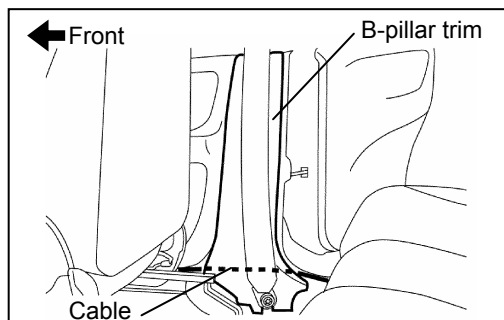

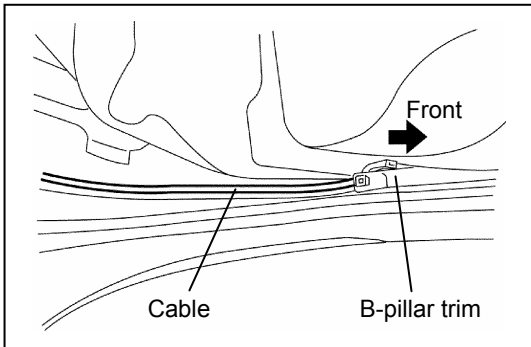

6. Run the cable inside the rear scuff plate along the vehicle harness.

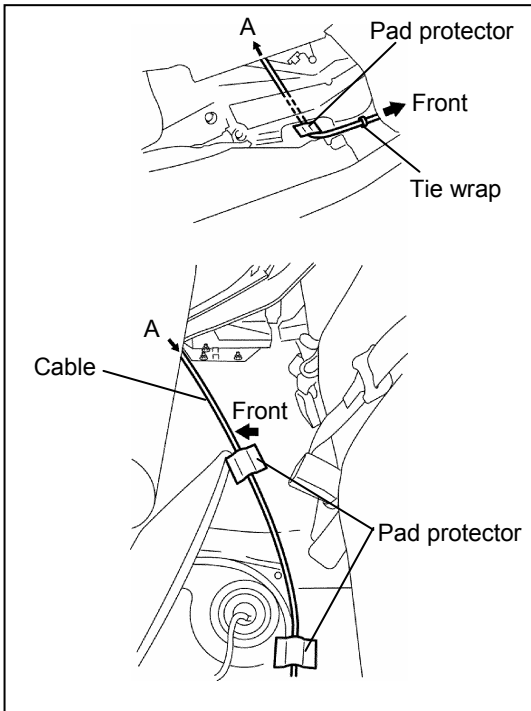

7. Partially peel back the carpet for the rear seat, then pull and route the cable.

8. Secure the cable at three points using pad protectors and tie wrap.

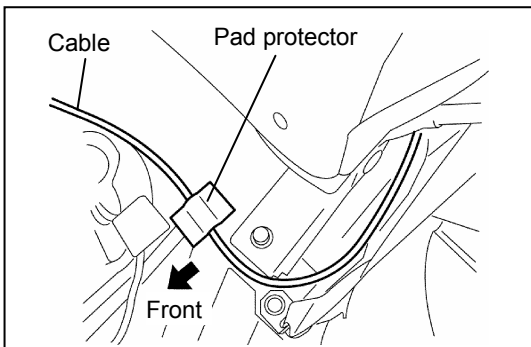

9. Pull and route the cable to the trunk compartment.

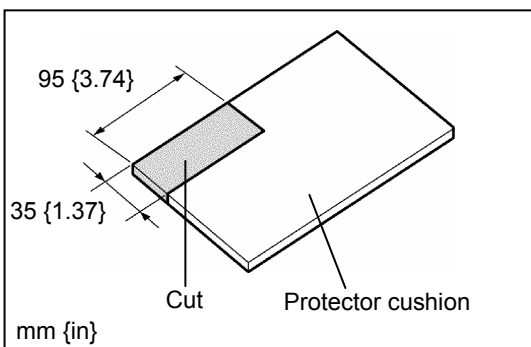

10. Cut the protector cushion to the dimensions show in the figure.

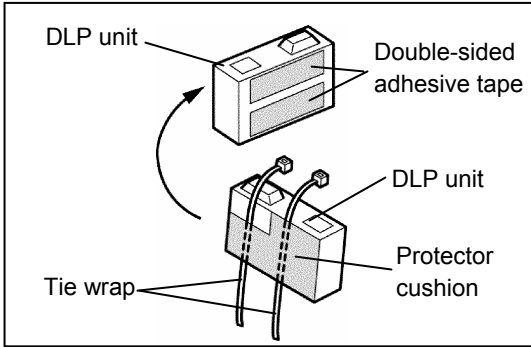

11. Clean the adhesion area with ISP alcohol.
12. Affix two pieces of double-sided adhesive tape to the DLP unit.
13. Attach the two tie wraps (long) to the DLP unit using the protector cushion.

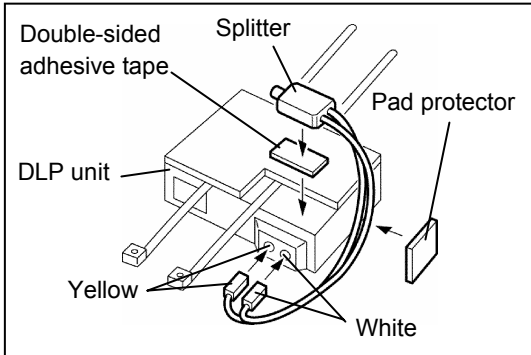

14. Connect the splitter connector to the DLP unit.
15. Affix double-sided adhesive tape to the splitter.
16. Affix the splitter to the top of the DLP unit with double-sided adhesive tape.
17. Secure the splitter cables with pad protector halves.

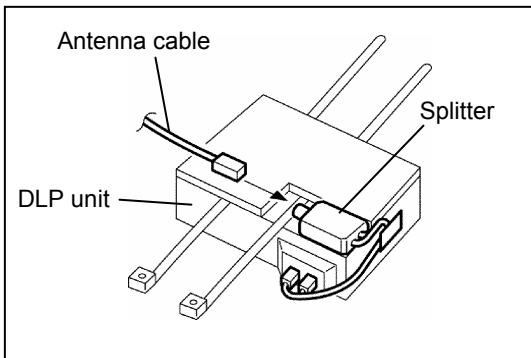

18. Connect the antenna cable connector to the splitter.

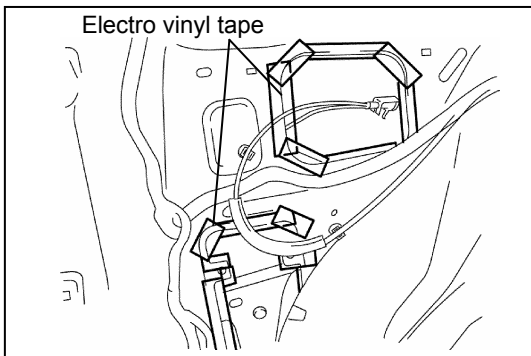

19. Affix electro vinyl tape around the edges.

CAUTION

- Corners are sharp, the electro vinyl tape is intended to protect the installer and components from the sharp edges.

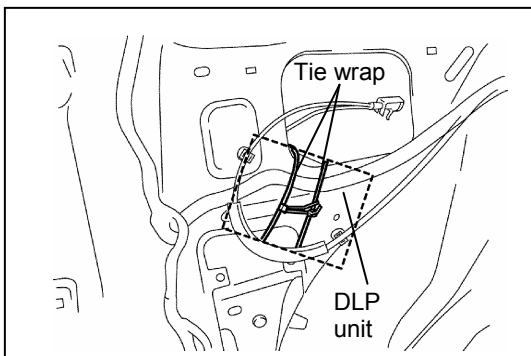

20. Clean the adhesion area with ISP alcohol.
21. Install the DLP unit to the inside of the side body panel of the trunk compartment using the double-sided adhesive tape and the tie wraps. (Connector points downward.)

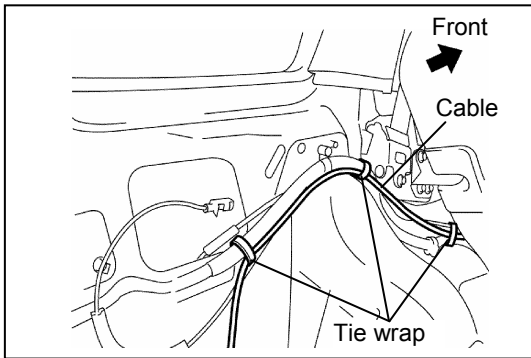

22. Secure the cable to the vehicle wiring harness on trunk side at three points using the three tie wraps.

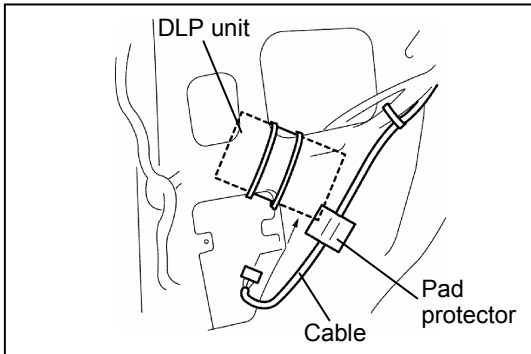

23. Connect the cable connector (black) to the DLP unit.

24. Secure the cable with the pad protector.

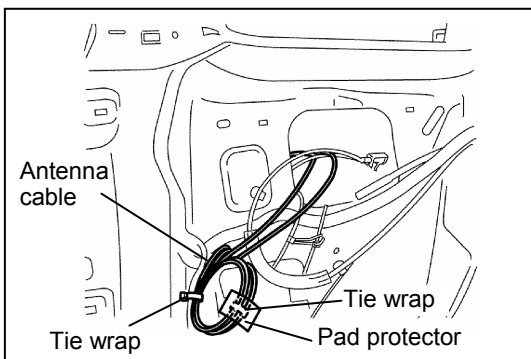

25. Bundle the extra antenna cable, then secure it to the vehicle wiring harness using the tie wrap.

26. Secure the antenna cable using the tie wrap and secure it to the vehicle panel with the pad protector.

CAUTION

- Be sure to bundle the antenna cable into a loop.

Note

- After completing the installation, refer to the owner's manual for instructions on how to reset the clock and preset radio stations, and record the trip meter numbers on the check sheet.

15 REINSTALLATION OF VEHICLE PARTS

- Install in the reverse order of "Part removal".

CAUTION

- After installing the vehicle parts, check for dirt. Clean any dirty parts.

- Perform the Inspection indicated on the last page of these installation instructions.

16 INSPECTION

- Inspect the installed / reinstalled parts for the following items.
- Inspection parts differ depending on the vehicle.

Inspection Parts	Inspection Items (○)			
	Clearance/Fit	Scratches/ Dirt/ Harness interference	Installation/ Tightening/ Engagement	Operation check
Rear combination light	○	○	○	○
Trunk side trim	○	○	○	
Trunk end trim	○	○	○	
Trunk board	○	○	○	
Trunk room mat	○	○	○	
Rear side trim	○	○	○	
Rear cup holder	○	○	○	
Mat set end plate	○	○	○	
Front side trim	○	○	○	
Scuff plate	○	○	○	
Glove compartment	○	○	○	
Audio unit	○	○	○	*1 ○
Dash panel	○	○	○	

○ : Applicable

*1: Refer to the Owner's Manual and the SATELLITE RADIO instruction manual, and verify that the system operates correctly.

Ex.: Turn the power ON, increase the volume, and press the SAT button.

- Direct access channel 184 is a test channel provided by Sirius.
Press the SAT button on the radio, and if properly installed you will receive a signal from the Sirius broadcast.

Note: Sirius broadcasts can only be received in an open area, enclosed spaces such as garages or work buildings block the satellite reception.

Date _____, _____, _____				
Vehicle. _____				
VIN. _____				
Approved		Checked		Person in charge

The term of validity for this sheet: 3 months