



GX-08 HIGH CAPACITY SPRAY GUN

7/8 INCH TIP THREAD

0803 • Form no. 0278995C

SAFETY PRECAUTIONS

⚠ WARNING

HAZARD: Injection injury - A high pressure stream produced by this equipment can pierce the skin and underlying tissues, leading to serious injury and possible amputation. See a physician immediately.

DO NOT TREAT AN INJECTION INJURY AS A SIMPLE CUT! Injection can lead to amputation. See a physician immediately.

The maximum operating range of the gun is 3600 PSI / 25 MPa fluid pressure.

PREVENTION:

- NEVER aim the gun at any part of the body.
- NEVER allow any part of the body to touch the fluid stream. DO NOT allow body to touch a leak in the fluid hose.
- NEVER put hand in front of the gun. Gloves will not provide protection against an injection injury.
- ALWAYS lock the gun trigger, shut the pump off, and release all pressure before servicing, cleaning the tip or guard, changing tip, or leaving unattended. Pressure will not be released by turning off the motor. The PRIME/SPRAY valve must be turned to PRIME to relieve the pressure. Refer to the PRESSURE RELIEF PRESSURE described in the pump manual.
- ALWAYS keep the tip guard in place while spraying. The tip guard provides some protection but is mainly a warning device.
- ALWAYS remove the spray tip before flushing or cleaning the system.
- The paint hose can develop leaks from wear, kinking and abuse. A leak can inject material into the skin. Inspect the hose before each use.
- NEVER use a spray gun without a trigger lock and trigger guard in place and in good working order.
- All accessories must be rated at or above 3600 PSI / 25 MPa. This includes spray tips, guns, extensions, and hose.

NOTE TO PHYSICIAN:

Injection into the skin is a traumatic injury. It is important to treat the injury as soon as possible. DO NOT delay treatment to research toxicity. Toxicity is a concern with some coatings injected directly into the blood stream. Consultation with a plastic surgeon or reconstructive hand surgeon may be advisable.

HAZARD: EXPLOSION OR FIRE - Solvent and paint fumes can explode or ignite. Severe injury and/or property damage can occur.

PREVENTION:

- Provide extensive exhaust and fresh air introduction to keep the air within the spray area free from accumulation of flammable vapors.
- Avoid all ignition sources such as static electricity sparks, electrical appliances, flames, pilot lights, hot objects, and sparks from connecting and disconnecting power cords or working light switches.
- Do not smoke in spray area.

- Fire extinguisher must be present and in good working order.
- Place pump at least 20 feet (6.1 m) from the spray object in a well ventilated area (add more hose if necessary). Flammable vapors are often heavier than air. Floor area must be extremely well ventilated. The pump contains arcing parts that emit sparks and can ignite vapors.
- The equipment and objects in and around the spray area must be properly grounded to prevent static sparks.
- Use only conductive or grounded high pressure fluid hose. Gun must be grounded through hose connections.
- Power cord must be connected to a grounded circuit.
- Always flush unit into a separate metal container, at low pump pressure, with spray tip removed. Hold gun firmly against side of container to ground container and prevent static sparks.
- Follow the material and solvent manufacturer's warnings and instructions.
- Use extreme caution when using materials with a flashpoint below 70° F (21° C). Flashpoint is the temperature that a fluid can produce enough vapors to ignite.
- Plastic can cause static sparks. Never hang plastic to enclose a spray area. Do not use plastic drop cloths when spraying flammable materials.
- Use lowest possible pressure to flush equipment.

HAZARD: EXPLOSION HAZARD DUE TO INCOMPATIBLE MATERIALS - will cause severe injury or property damage.

PREVENTION:

- Do not use materials containing bleach or chlorine.
- Do not use halogenated hydrocarbon solvents such as bleach, mildewcide, methylene chloride and 1,1,1 - trichloroethane. They are not compatible with aluminum.
- Contact your coating supplier about the compatibility of material with aluminum.

HAZARD: HAZARDOUS VAPORS - Paints, solvents, insecticides, and other materials can be harmful if inhaled or come in contact with the body. Vapors can cause severe nausea, fainting, or poisoning.

PREVENTION:

- Use a respirator or mask if vapors can be inhaled. Read all instructions supplied with the mask to be sure it will provide the necessary protection.
- Wear protective eyewear.
- Wear protective clothing as required by coating manufacturer.

HAZARD: GENERAL - Can cause severe injury or property damage.

PREVENTION:

- Read all instructions and safety precautions before operating equipment.
- Always disconnect the motor from the power supply before working on the equipment.
- Follow all appropriate local, state, and national codes governing ventilation, fire prevention, and operation.
- The United States Government Safety Standards have been adopted under the Occupational Safety and Health Act (OSHA). These standards, particularly part 1910 of the General Standards and part 1926 of the Construction Standards should be consulted.
- Use only manufacturer authorized parts. User assumes all risks and liabilities when using parts that do not meet the minimum specifications and safety devices of the pump manufacturer.
- Before each use, check all hoses for cuts, leaks, abrasion or bulging of cover. Check for damage or movement of couplings. Immediately replace the hose if any of these conditions exist. Never repair a paint hose. Replace it with another grounded high-pressure hose.
- All hoses, swivels, guns, and accessories must be pressure rated at or above 3600PSI / 25 MPa.
- Do not spray outdoors on windy days.
- Wear clothing to keep paint off skin and hair.

OPERATING INSTRUCTIONS

LOCKING AND UNLOCKING THE GUN

Always lock the gun off when it is not in use. To lock the gun, turn the trigger lock forward and slightly down until it stops. To unlock the gun, turn the trigger lock so that it is vertical and pointing up.

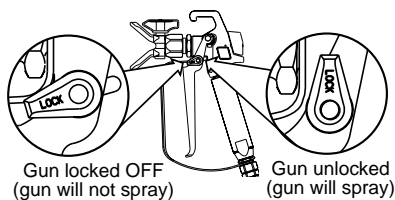

⚠ WARNING

POSSIBLE INJECTION HAZARD.

Do not spray without the tip guard in place. Never trigger the gun unless the tip is in either the spray or the unclog position. Always lock the gun off before removing, replacing or cleaning the tip.

ATTACHING THE TIP

1. Thread the spray tip onto the gun. Tighten the nut first by hand, then tighten more firmly with a wrench.

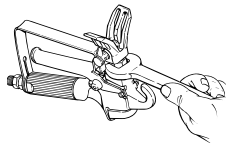

ATTACHING THE FILTER

1. Insert the tapered plastic end of the paint filter into the fitting on the spray gun.
2. Place the spring into the filter housing.
3. Place the white sealing washer into the filter housing with the lipped side up.
4. Slide the filter housing over the filter and screw the filter housing securely to the fitting.

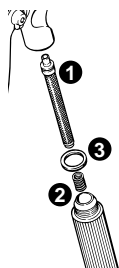

UNCLOGGING THE SPRAY TIP

⚠ WARNING

Do not attempt to unclog or clean the tip with your finger. Do not use a needle or other sharp pointed instrument to clean the tip. The hard tungsten carbide is brittle and can be chipped.

The spray gun is equipped with a reversible tip which allows you to blow out any particles of old paint or other contaminants that may obstruct the paint flow through the tip. If the spray pattern becomes distorted or stops completely while the gun is triggered, follow these steps:

1. Release the trigger and lock the gun off.
2. Rotate the reversible tip cylinder arrow 180° so that the point of the arrow is toward the rear of the gun.
3. Unlock the gun and squeeze the trigger, pointing the gun at a scrap piece of wood or cardboard. This allows pressure in the spray hose to blow out the obstruction. When the nozzle is clean, paint will come out in a straight, high pressure stream.
4. Release the trigger and lock the gun off.
5. Reverse the tip so the arrow points forward again.
6. Unlock the gun and resume spraying.

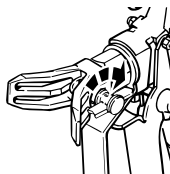

⚠ CAUTION

If spraying with latex paint, use warm soapy water for cleaning. If using oil or alkyd-based paints, use mineral spirits or paint thinner. Refer to the paint manufacturer's instructions for specific recommendations.

Do not use mineral spirits or paint thinner on latex paint, or the mixture will turn into a jellylike substance which is difficult to remove.

CLEANING THE SPRAY GUN FILTER

The spray gun includes a filter to catch particles before they reach the spray tip. If this filter becomes clogged or obstructed it will reduce the flow of paint, changing the spray pattern and possibly damaging the filter.

This filter must be cleaned daily. If the material being used is old or contains hardened particles, then the filter should be cleaned approximately every 4 hours. If the filter is not cleaned at the proper time, it will plug and blow pin holes in the filter. Holes in the filter will allow unwanted particles to get into the spray tip, causing the spray tip to clog.

Clean the filter by rinsing it thoroughly in water or the type of solvent appropriate to the paint you are using. If this is not sufficient, use a natural or nylon bristle brush dipped in water or the appropriate solvent. Do not use a wire brush or any sharp instrument on the filter.

CLEANING THE GUN

1. Check that the spray tip assembly has been removed from the gun.
2. Remove the filter and reattach the filter housing to the gun.
3. Run the appropriate solvent through the pump.
4. Hold the metal part of the gun against a metal container to ground the gun.
5. Trigger the gun into the container until it is flushed clean. Use the lowest possible pressure.

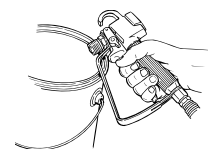

Part No.	Application	Filter Type	Mesh Number	Color of Filter Body	Qty.
0154918	Synthetic resin, enamels, clean varnishes, stains azures	Extrafine	180 mesh 0.084 mm	red	2 pack
0154675	Base coat enamels, primer enamels, fillers, marking paints, textured enamels	Fine	100 mesh 0.140 mm	yellow	2 pack
0154842	Emulsions, latex paints, acrylic paints	Medium	50 mesh 0.315 mm	white	2 pack
0089957	Filler paints, large area surfaces	Coarse	30 mesh 0.560 mm	green	2 pack

REPLACING THE VALVE SPRING UNIT

NOTE: Replace the packing if the spray gun is disassembled. Replace the sliding pins if they are worn.

1. Unscrew the spray tip.
2. Lock the gun in the ON position and remove the diffuser with a wrench.
3. Unlock the gun.
4. Unscrew the nut with a wrench and remove the retainer block.
5. Remove the sliding pins with care and store them in a safe place so they will not be lost.
6. Drive the valve spring unit forward from the back of the retainer block. Use the handle of a wooden hammer or similar soft tool to avoid damaging the valve spring unit.

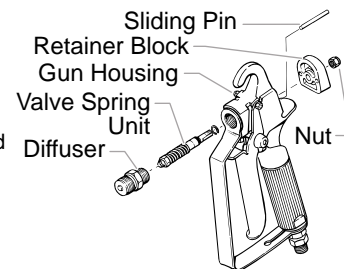

PARTS LIST

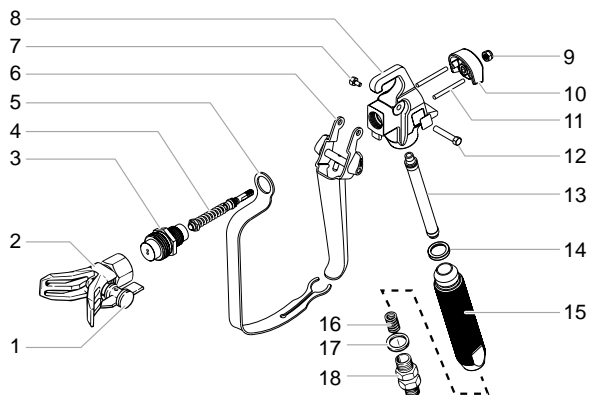

Item	Part #	Description	Item	Part #	Description
1		Tip	10	0296222	Retainer block
2	0501011	Holder assembly	11	0296286	Sliding pin
3	0296261	Diffuser, 7/8"	12	0296287	Trigger screw (long)
4	0296270	Valve spring unit	13	0034377	Filter, white
5	0296230	Trigger guard	14	0296289	Washer
6	0296285	Trigger assembly	15	0296342	Handle
7	0296284	Trigger screw (short)	16	0043590	Spring
8	0296228	Gun housing	17	0296283	Sealing ring
9	9910201	Hex nut	18	0296301	Fitting