

Safety Precautions

⚠ WARNING

HAZARD: Injection injury - A high pressure stream produced by this equipment can pierce the skin and underlying tissues, leading to serious injury and possible amputation. See a physician immediately.

DO NOT TREAT AN INJECTION INJURY AS A SIMPLE CUT! Injection can lead to amputation. See a physician immediately.

The maximum operating range of the gun is 3600 PSI / 25 MPa fluid pressure.

PREVENTION:

- NEVER aim the gun at any part of the body.
- NEVER allow any part of the body to touch the fluid stream. DO NOT allow body to touch a leak in the fluid hose.
- NEVER put hand in front of the gun. Gloves will not provide protection against an injection injury.
- ALWAYS lock the gun trigger, shut the pump off, and release all pressure before servicing, cleaning the tip or guard, changing tip, or leaving unattended. Pressure will not be released by turning off the motor. The PRIME/SPRAY valve must be turned to PRIME to relieve the pressure. Refer to the PRESSURE RELIEF PROCEDURE described in the pump manual.
- ALWAYS keep the tip guard in place while spraying. The tip guard provides some protection but is mainly a warning device.
- ALWAYS remove the spray tip before flushing or cleaning the system.
- The paint hose can develop leaks from wear, kinking and abuse. A leak can inject material into the skin. Inspect the hose before each use.
- NEVER use a spray gun without a trigger lock and trigger guard in place and in good working order.
- All accessories must be rated at or above the maximum operating pressure range of the airless sprayer. This includes spray tips, guns, extensions, and hose.

NOTE TO PHYSICIAN:

Injection into the skin is a traumatic injury. It is important to treat the injury as soon as possible. DO NOT delay treatment to research toxicity. Toxicity is a concern with some coatings injected directly into the blood stream. Consultation with a plastic surgeon or reconstructive hand surgeon may be advisable.

HAZARD: EXPLOSION OR FIRE - Solvent and paint fumes can explode or ignite. Severe injury and/or property damage can occur.

PREVENTION:

- Provide extensive exhaust and fresh air introduction to keep the air within the spray area free from accumulation of flammable vapors.
- Avoid all ignition sources such as static electricity sparks, electrical appliances, flames, pilot lights, hot objects, and sparks from connecting and disconnecting power cords or working light switches.
- Do not smoke in spray area.
- Fire extinguisher must be present and in good working order.
- Place pump at least 20 feet (6.1 m) from the spray object in a well ventilated area (add more hose if necessary). Flammable vapors are often heavier than air. Floor area must be extremely well ventilated. The pump contains arcing parts that emit sparks and can ignite vapors.
- The equipment and objects in and around the spray area must be properly grounded to prevent static sparks.

- Use only conductive or grounded high pressure fluid hose. Gun must be grounded through hose connections.
- Power cord must be connected to a grounded circuit.
- Always flush unit into a separate metal container, at low pump pressure, with spray tip removed. Hold gun firmly against side of container to ground container and prevent static sparks.
- Follow the material and solvent manufacturer's warnings and instructions.
- Use extreme caution when using materials with a flashpoint below 70° F (21° C). Flashpoint is the temperature that a fluid can produce enough vapors to ignite.
- Plastic can cause static sparks. Never hang plastic to enclose a spray area. Do not use plastic drop cloths when spraying flammable materials.
- Use lowest possible pressure to flush equipment.

HAZARD: EXPLOSION HAZARD DUE TO INCOMPATIBLE MATERIALS - will cause severe injury or property damage.

PREVENTION:

- Do not use materials containing bleach or chlorine.
- Do not use halogenated hydrocarbon solvents such as bleach, mildewcide, methylene chloride and 1,1,1 - trichloroethane. They are not compatible with aluminum.
- Contact your coating supplier about the compatibility of material with aluminum.

HAZARD: HAZARDOUS VAPORS - Paints, solvents, insecticides, and other materials can be harmful if inhaled or come in contact with the body. Vapors can cause severe nausea, fainting, or poisoning.

PREVENTION:

- Use a respirator or mask if vapors can be inhaled. Read all instructions supplied with the mask to be sure it will provide the necessary protection.
- Wear protective eyewear.
- Wear protective clothing as required by coating manufacturer.

HAZARD: GENERAL - Can cause severe injury or property damage.

PREVENTION:

- Read all instructions and safety precautions before operating equipment.
- Always disconnect the motor from the power supply before working on the equipment.
- Follow all appropriate local, state, and national codes governing ventilation, fire prevention, and operation.
- The United States Government Safety Standards have been adopted under the Occupational Safety and Health Act (OSHA). These standards, particularly part 1910 of the General Standards and part 1926 of the Construction Standards should be consulted.
- Use only manufacturer authorized parts. User assumes all risks and liabilities when using parts that do not meet the minimum specifications and safety devices of the pump manufacturer.
- Before each use, check all hoses for cuts, leaks, abrasion or bulging of cover. Check for damage or movement of couplings. Immediately replace the hose if any of these conditions exist. Never repair a paint hose. Replace it with another grounded high-pressure hose.
- All hoses, swivels, guns, and accessories must be pressure rated at or above the maximum operating pressure range of the airless sprayer.
- Do not spray outdoors on windy days.
- Wear clothing to keep paint off skin and hair.

Using the Gun Trigger Lock

Always engage the gun's trigger lock when the gun is not in use.

1. To lock the trigger, rotate the trigger lock forward until it stops.
2. To unlock the trigger, rotate the trigger lock backward until it is vertical.

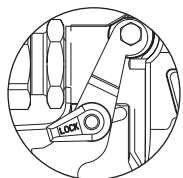

Trigger locked
(gun will not spray)

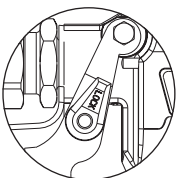

Trigger unlocked
(gun will spray)

Setup

⚠ WARNING

Never attempt to assemble, change, or clean the gun, tip, or tip guard without first relieving pressure from the spray system. Follow the "Pressure Relief Procedure" in the sprayer's Owner's Manual.

⚠ WARNING

Always use a tip safety guard for added protection against injection. Beware that the guard alone will not prevent injection. Never cut off tip guard! Always engage gun trigger lock when the gun is not in use. Before servicing equipment, consult Owner's Manuals and follow all warnings.

1. Set up the sprayer. Refer to the instructions in the sprayer's Owner's Manual.
2. Attach a grounded, airless spray hose to the material inlet on the gun. Using two wrenches (one on the gun and one on the hose), tighten securely.
3. With the tip and tip guard off the gun, start the sprayer. Flush and prepare the spray system according to the sprayer's Owner's Manual. Inspect the spray system to make sure that all fittings are secure and that there are no leaks.
4. Perform the "Pressure Relief Procedure" described in the sprayer's Owner's Manual.
5. Using a pen or similar object, insert the tip seal and seal into the back of the tip guard. Press in for final adjustment.
6. Insert the tip into the slot on the tip guard.
7. Thread the tip guard onto the gun. Position the tip guard in the desired spraying position, then tighten securely by hand.

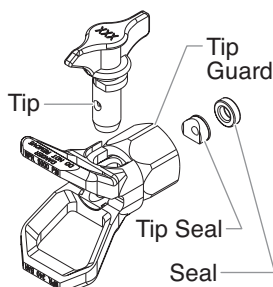

NOTE: The arrow on the tip handle should be pointing in the forward direction for spraying.

Operation

1. Make sure the arrow on the tip handle is pointing in the forward direction for spraying.
2. Start the sprayer. Refer to the instructions in the sprayer's Owner's Manual.
3. Adjust the fluid pressure on the sprayer until the spray is completely atomized. Always spray at the lowest pressure necessary to get the desired results.

NOTE: The spray tip determines the size of spray pattern and coverage. When more coverage is needed, use a larger tip instead of increasing fluid pressure.

4. To clear a clogged tip:
 - a. Rotate the tip 180° so that the arrow on the tip handle is pointing opposite the spray direction.
 - b. Trigger the gun once so that the pressure can blow the clog out.

⚠ CAUTION

Never pull the trigger more than once at time with the tip in the reverse position.

- c. Continue this procedure until the tip is clear of the clog.

Changing a Tip

Tips can be removed and replaced easily without disassembling the gun.

⚠ WARNING

Never attempt to change or clean the tip or tip guard without first performing the "Pressure Relief Procedure."

1. Perform the "Pressure Relief Procedure" described in the sprayer's Owner's Manual.
2. Remove the tip from the slot on the tip guard.
3. Insert the new tip into the slot on the tip guard. The arrow on the tip handle should be pointing in the forward direction for spraying.

Removing the Seal and Tip seal

1. Remove the tip and tip guard from the spray gun.
2. Remove the seal and tip seal from the back of the tip guard.

Identifying Tip Sizes

To identify tip sizes, use the following formula. A "517" tip size will be used in this example.

The first digit multiplied by two represents the size of the spray pattern when spraying 12" away from the work surface:

$$5 \times 2 = 10" \text{ spray pattern}$$

The second two digits represent the diameter of the orifice on the tip:

$$17 = .017" \text{ orifice}$$

NOTE: Worn spray tips will adversely affect the spray pattern and result in reduced production, poor finish, and wasted material. Replace worn tips immediately.

Cleanup

Maintaining a clean gun is important to ensure trouble-free operation. Flush the gun after each use and store in a dry location. Do not leave the gun or any of its parts in water or solvents.

⚠ WARNING

Special cleanup instructions for use with flammable solvents:

- Always flush spray gun preferably outside and at least one hose length from spray pump.
- If collecting flushed solvents in a one gallon metal container, place it into an empty five gallon container, then flush solvents.
- Area must be free of flammable vapors.
- Follow all cleanup instructions.

⚠ CAUTION

The sprayer, hose, and gun should be cleaned thoroughly after daily use. Failure to do so permits material to cake, seriously affecting the performance of the unit.

⚠ WARNING

Always spray at minimum pressure with the tip and tip guard removed when using mineral spirits or any other solvent to clean the sprayer, hose, or gun. Static electricity buildup may result in a fire or explosion in the presence of flammable vapors. Hold the gun firmly against a metal container while flushing.

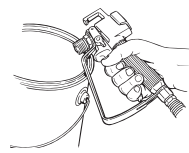

Maintenance

⚠ WARNING

Follow all safety precautions as described in the Safety Precautions section of this manual before proceeding.

NOTE: Refer to the Parts List section in this manual for part identification.

Replacing/Serviceing the Seal Assembly

If your spray gun leaks or spits at the tip when you release the trigger, the needle or seat is worn, damaged, or dirty and must be replaced or cleaned.

⚠ WARNING

Never attempt to perform maintenance on the spray gun without first performing the "Pressure Relief Procedure."

1. Disconnect the fluid hose from the gun.
2. Remove the tip and tip guard.
3. With the trigger depressed, remove the diffuser from the front of the gun.
4. Remove the lock nut, rear housing, and retractor pins from the rear of the gun head.
5. Remove the seal assembly from the front of the gun head by pushing or gently tapping at the back of the seal assembly.
6. Soak the removed parts in the appropriate solvent and wipe clean.
7. Inspect the parts for wear or damage and use new parts during reassembly of the gun, when necessary.

NOTE: Lubricate all packings and moving parts before reassembly with a lithium-based grease.

8. Install the seal assembly into the front of the gun head.
9. Install the retractor pins into the rear of the gun head. Slide the rear housing onto the retractor pins and secure in position with the lock nut.
10. With the trigger depressed, install the diffuser into the front of the gun head and tighten securely with a wrench.
11. Perform the "Adjusting the Seal Assembly" procedure described below.

Adjusting the Seal Assembly

⚠ WARNING

Proper adjustment of the seal assembly is essential to ensure positive shut-off when the trigger is released.

1. Tighten the lock nut until the rear housing is flush against the gun head.
2. Unscrew the lock nut 3/4 of a turn.

NOTE: To check the adjustment of the seal assembly:

1. Move the gun trigger lock to the locked position.
2. Pull the trigger.

With the trigger lock engaged, there should be 1/32" of movement between the lock nut and the rear housing while pulling the trigger.

Replacing/Removing the Filter

1. Pull the bottom of the trigger guard forward so that it comes loose from the handle assembly.
2. Loosen and remove the handle assembly from the gun head.
3. Pull the old filter out of the gun head.
4. Slide the new filter, tapered end first, into the gun head.
5. Make sure the handle seal is in position and thread the handle assembly into the gun head until secure.
6. Snap the trigger guard back onto the handle assembly.

Gun Filter Chart

Part Number	Application	Filter Type	Color of Filter Body
0089960	Synthetic resin, enamels, clean varnishes, stains azures	Extrafine	red
0089959	Base coat enamels, primer enamels, fillers, marking paints, textured enamels	Fine	yellow
0089958	Emulsions, latex paints, acrylic paints	Medium	white
0089957	Filler paints, large area surfaces	Coarse	green

Parts List

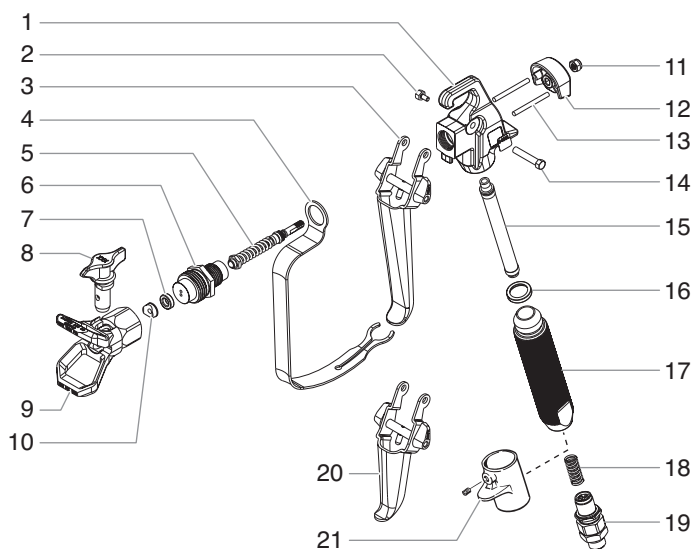

Item	Part #	Description	Quantity
1	0296228	Gun head	1
2	0296284	Trigger screw, short	1
3	0296285	Trigger assembly, 4-finger gun	1
4	0296230	Trigger guard	1
5	0296270	Seal assembly	1
6	0296261	Diffuser	1
7	0297045	Seal.....	1
8	0550517	Tip assembly, XL1 (includes items 7 and 10)	1
9	0502949	Tip guard	1
10	0297007	Tip seal	1
11	9910201	Lock nut	1
12	0296222	Rear housing	1
13	0296286	Retractor pin	2
14	0296287	Trigger screw, long	1
15	0089958	Filter, medium	1
16	0296289	Handle seal.....	1
17	0296342	Handle	1
18	0296343	Spring	1
19	0347706	Swivel	1
20	0296291	Trigger assembly, 2-finger gun	1
21	0279185	Collar assembly, 2-finger gun	1
22	0296231	G-10XL label (not shown).....	1
	0296345	Handle assembly (includes items 17-19)	
	0296294	Gun repair kit (includes items 5, 6, and 11)	

SprayTECH



1770 Fernbrook Lane
Minneapolis, MN 55447

Technical Assistance: 1-800-292-4637

Order Entry: 1-800-443-4500

Fax: 1-800-525-9501

www.spraytechinc.com