

TROUBLESHOOTING

Problem

The sprayer does not start up.

Cause

1. The sprayer is not plugged in.
2. The ON/OFF switch is set to OFF.
3. A fuse is blown in the sprayer.
4. Low or no voltage is coming from the wall plug.
5. The sprayer was turned off while still under pressure.
6. The extension cord is damaged or has too low a capacity.
7. The thermal overload on the sprayer is tripped.
8. There is a problem with the motor.

Solution

1. Plug the sprayer in.
2. Turn the ON/OFF switch to ON.
3. Replace the blown fuse with the proper replacement.
4. Properly test the power supply voltage.
5. Turn the PRIME/SPRAY knob to PRIME.
6. Replace the extension cord.
7. Allow the motor to cool and move the sprayer to a cooler spot.
8. Take the sprayer to a Wagner Authorized Service Center.

The sprayer starts up but does not draw in paint when the PRIME/SPRAY knob is set to PRIME.

1. The unit will not prime properly or has lost prime.
2. The paint bucket is empty or the suction tube is not totally immersed in the paint.
3. The suction filter is clogged.
4. The suction tube is loose at the inlet valve.
5. The inlet valve is stuck.
6. The outlet valve is stuck.
7. The PRIME/SPRAY valve is plugged.
8. The inlet valve is worn or damaged.
9. There is a problem with the diaphragm.
10. The hydraulic oil level is low or empty.

1. Try to prime the unit again.
2. Immerse the suction tube in paint.
3. Clean the suction set filter.
4. Clean the tube connection and tighten it securely.
5. Clean the inlet valve.
6. Clean the outlet valve and replace any worn parts.
7. Take the sprayer to a Wagner Authorized Service Center.
8. Replace the inlet valve.
9. Take the sprayer to a Wagner Authorized Service Center.
10. Take the sprayer to a Wagner Authorized Service Center.

The sprayer draws up paint but the pressure drops when the gun is triggered.

1. The spray tip is worn.
2. The suction set filter is clogged.
3. The gun or spray tip filter is plugged.
4. The paint is too heavy or coarse.
5. The outlet valve assembly is dirty or worn.
6. The inlet valve assembly is damaged or worn.

1. Replace the spray tip with a new tip.
2. Clean the suction set filter.
3. Clean or replace the proper filter. Always keep extra filters on hand.
4. Thin or strain the paint.
5. Clean or replace the outlet valve assembly.
6. Replace the inlet valve.

The spray gun will not shut off.

1. The inlet or outlet valve ball or ball seat is worn.
2. Foreign matter or paint has built up between the ball and the seat.

1. Take the sprayer to a Wagner Authorized Service Center.
2. Take the sprayer to a Wagner Authorized Service Center.

The spray gun leaks.

1. Internal parts of the gun are worn or dirty.

1. Take the sprayer to a Wagner Authorized Service Center.

The tip assembly leaks.

1. The tip was assembled incorrectly.
2. A seal is worn.

1. Check the tip assembly and assemble properly.
2. Replace the seal.

The spray gun will not spray.

1. The spray tip, the gun filter or the tip filter is plugged.
2. The spray tip is in the CLEAN position.

1. Clean the spray tip, gun filter or tip filter.
2. Put the tip in the SPRAY position.

The paint pattern is tailing.

1. The pressure is set too low.
2. The gun, the tip, or the suction filter is plugged.
3. The suction tube is loose at the inlet valve.
4. The tip is worn.
5. The paint is too thick.

1. Increase the pressure.
2. Clean the filters.
3. Tighten the suction tube fitting.
4. Replace the spray tip.
5. Thin the paint.

The thermal overload tripped and shut off the sprayer.

1. The motor overheated.
2. The extension cord is too long or is too small a gauge.
3. Paint has built up on the motor.
4. The motor was started while the sprayer was under pressure.
5. The sprayer was sitting in the hot sun.

1. Allow to cool for 30 minutes.
2. Allow to cool for 30 minutes and replace the extension cord with a shorter extension or a thicker gauge cord.
3. Clean the paint from the motor.
4. Restart the sprayer in the PRIME mode.
5. Move the sprayer out of the sun.

NOTE: When the PRIME/SPRAY valve is on SPRAY and there is flow through the return tube, remove the PRIME/SPRAY valve and clean or replace it.

NOTE: The electric motor should always be kept clean and dry. Paint acts as an insulator. Too much paint on the motor will cause the motor to overheat.

PARTS LISTING / SCHÉMAS DES PIÈCES / DIAGRAMAS DE LAS PIEZAS

Final Assembly / Montage Final / Ensamble Fina

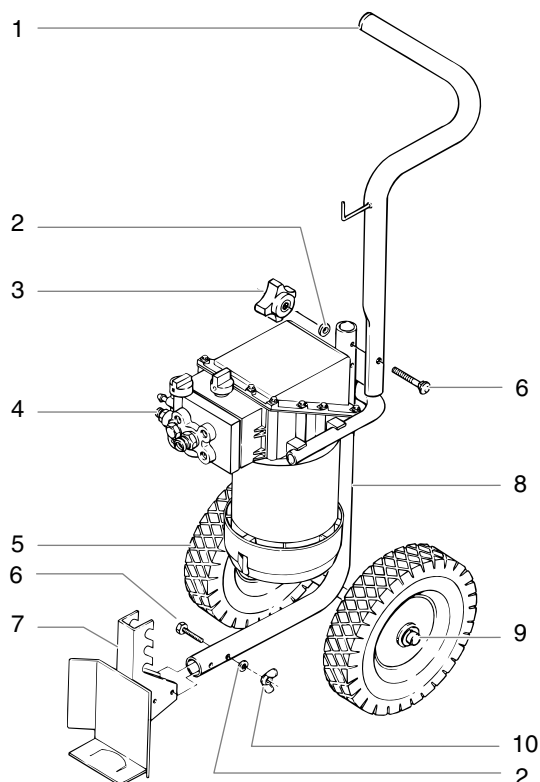

FRANÇAIS • MONTAGE FINAL

ARTICLE	No DE PIÈCE	DESCRIPTION	QUANTITÉ
1	0270581	Guidon de chariot	1
2	9821503	Rondelle de blocage	3
3	0288661	Écrou à oreilles	3
4	-----	Ensemble de pompe à peinture (voir la liste séparée)	1
5	0270582	Roue	2
6	9802518	Boulon	3
7	0270579	Support de seau	18
8	0270580	Ensemble de chariot	1
9	0275728	Enjoliveur	2
10	9810111	Écrou à ailettest	2

ENGLISH • FINAL ASSEMBLY

ITEM	PART NO.	DESCRIPTION	QTY.
1	0270581	Cart handle	1
2	9821503	Lock washer	3
3	0288661	Thumb nut	1
4	-----	Paint pump assembly (see separate listing)	1
5	0270582	Wheel	2
6	9802518	Bolt	3
7	0270579	Pail bracket	1
8	0270580	Cart assembly	1
9	0275728	Hub cap	2
10	9810111	Wing nut	2

ESPAÑOL • ENSAMBLE FINA

ARTÍCULO	# PIEZA	DESCRIPCIÓN	CANTIDAD
1	0270581	Manubrio del carro	1
2	9821503	Rondana de seguridad	3
3	0288661	Tuerca de mariposa	3
4	-----	Conjunto de la bomba de pintura (vea la lista separada)	1
5	0270582	Rueda	2
6	9802518	Perno	3
7	0270579	Soporte de la cubeta	1
8	0270580	Conjunto del carro	1
9	0275728	Tapacubos	2
10	9810111	Tuerca de palomilla	2

Paint Pump Assembly / Ensemble de Pompe à Peinture / Conjunto de la Bomba de Pintura

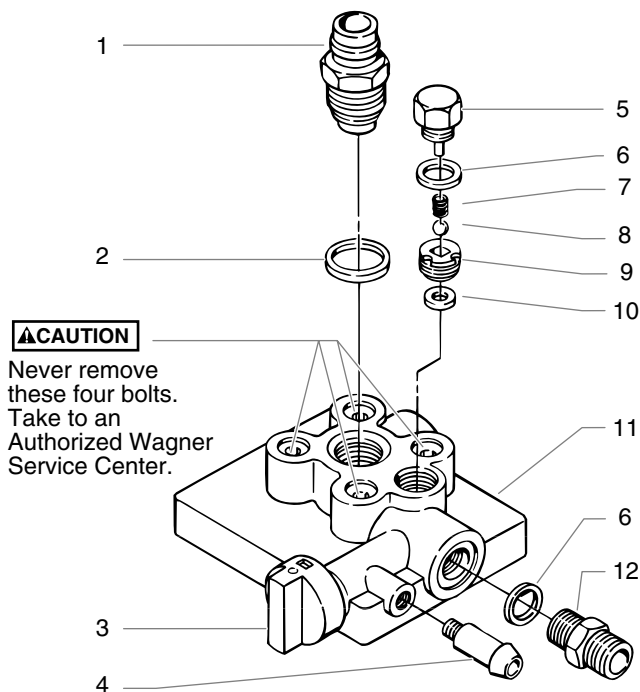

FRANÇAIS • ENSEMBLE DE POMPE À PEINTURE

ARTICLE	No DE PIÈCE	DESCRIPTION	QUANTITÉ
1	0281113	Ensemble de soupape d'admission (comprend l'article 2)	1
2	0089482	Rondelle d'étanchéité, en nylon	1
3	0288748	Bouton seulement.	1
4	0088715	Raccord du tube de retour	1
5	0089564	Capuchon de l'ensemble de sortie	1
6	9970103	Rondelle d'étanchéité en cuivre	2
7	0047485	Ressort de sortie	1
8	0093635	Bille de carbure de 6 mm	1
9	0090348	Ensemble de bille et de siège de la soupape de sortie	1
10	0089494	Joint d'étanchéité de sortie	1
11	0270200	Pompe à peinture avec soupape.	1
12	0288379	Raccord de sortie	1
	0288172	Nécessaire de réparation	1
		Remplace le support et le siège	

ENGLISH • PAINT PUMP ASSEMBLY

ITEM	PART NO.	DESCRIPTION	QTY.
1	0281113	Valve, Inlet Assembly (includes item 2)	1
2	0089482	Washer, Sealing, Nylon.	1
3	0288748	Knob Only	1
4	0088715	Fitting, Return Tube	1
5	0089564	Cap, Outlet Assembly	1
6	9970103	Washer, Sealing, Copper	2
7	0047485	Spring, Outlet	1
8	0093635	Ball, 6mm, Carbide	1
9	0090348	Seat, Ball, Outlet Assembly.	1
10	0089494	Seal, Outlet	1
11	0270200	Paint Pump with Valve	1
12	0288379	Fitting, Outlet	1
	0288172	Repair Kit	1
		Replaces both Holder & Seat	

ESPAÑOL • CONJUNTO DE LA BOMBA DE PINTURA

ARTÍCULO	# PIEZA	DESCRIPCIÓN	CANTIDAD
1	0281113	Válvula, Conjunto de la entrada (incluye el artículo 2)	1
2	0089482	Rondana, Selladura, Nailon	1
3	0288748	Perilla solamente	1
4	0088715	Adaptador, Tubo de retorno	1
5	0089564	Anillo, Conjunto de la salida	1
6	9970103	Rondana, Selladura, Cobre.	2
7	0047485	Resorte, Salida	1
8	0093635	Bola, 6 mm, Carburo.	1
9	0090348	Asiento, Bola, Conjunto de la salida	1
10	0089494	Sello, Salida	1
11	0270200	Bomba de pintura con válvula.	1
12	0288379	Adaptador, Salida	1
	0288172	Juego para reparar.	1
		Para reemplazar el sujetador y el asiento	

0270174 Suction Set Assembly / Ensemble d'aspiration / Conjunto del Equipo de Succión

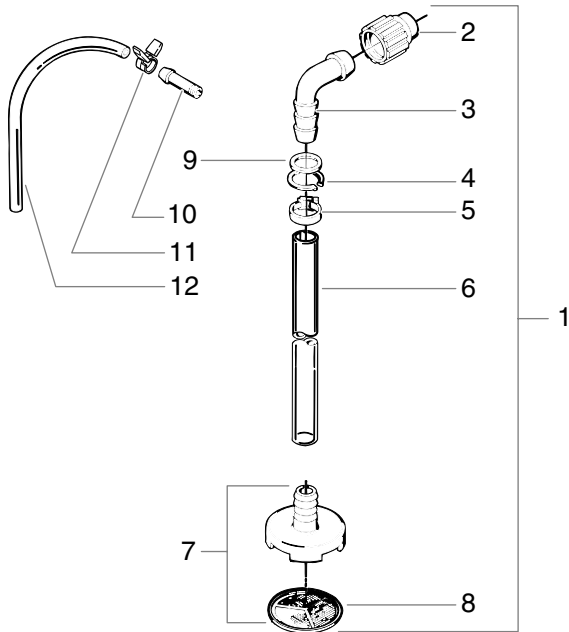

FRANÇAIS • ENSEMBLE D'ASPIRATION

ARTICLE	No DE PIÈCE	DESCRIPTION	QUANTITÉ
1	0270133	Tube d'aspiration, au complet	1
		(comprend les articles 2 à 9)	
2	0090622	Écrou d'aspiration	1
3	0281314	Raccord coudé 3/4 x 1 po.	1
4	0088931	Collier de retenue	1
5	0089882	Bride	2
6	0270360	Tuyau d'aspiration.	1
7	0270162	Boîtier de filtre et filtre.	1
8	0270369	Filtre	1
9	0090621	Rondelle.	1
10	0088715	Raccord de tuyau de retour.	1
11	0327226	Bride	1
12	0270363	Tube de retour	1

ENGLISH • SUCTION SET ASSEMBLY

ITEM	PART NO.	DESCRIPTION	QTY.
1	0270133	Suction Tube Complete.	1
		(Includes Items 2 thru 9)	
2	0090622	Nut, Suction	1
3	0281314	Elbow, Adapter, 3/4" x 1"	1
4	0088931	Ring, Snap	1
5	0089882	Clamp.	2
6	0270360	Hose, Suction	1
7	0270162	Filter Housing & Filter	1
8	0270369	Filter.	1
9	0090621	Washer.	1
10	0088715	Fitting, Return Hose	1
11	0327226	Clamp.	1
12	0270363	Tubing, Return	1

ESPAÑOL • CONJUNTO DEL EQUIPO DE SUCCIÓN

ARTÍCULO	# PIEZA	DESCRIPCIÓN	CANTIDAD
1	0270133	Tubo de succión completo	1
		(incluye los artículos del 2 al 9)	
2	0090622	Tuerca, Succión	1
3	0281314	Codo, Conexión, 3/4" x 1".	1
4	0088931	Argolla, de Retención	1
5	0089882	Abrazadera.	2
6	0270360	Manguera, Succión.	1
7	0270162	Caja del filtro y Filtro.	1
8	0270369	Filtro	1
9	0090621	Rondana.	1
10	0088715	Adaptador, Manguera de retorno.	1
11	0327226	Abrazadera.	1
12	0270363	Tubo, Retorno.	1

G-06 Spray Gun / Pistolet G-06 / G-06 Pistola de Atomización

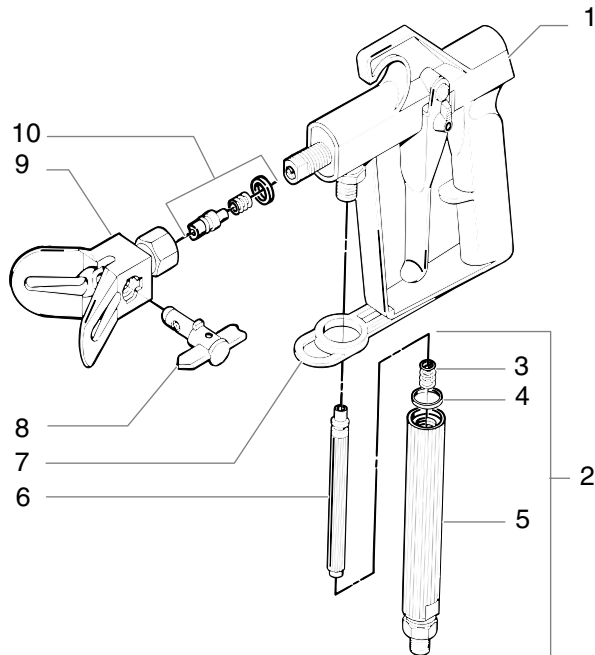

ENGLISH • G-06 SPRAY GUN

NOTE: This gun is used on the CW models. If you own an EX model, refer to the manual that comes with your G-09 spray gun for part numbers.

ITEM	PART NO.	DESCRIPTION
1	0293004	G-06 gun assembly (includes items 2 through 7)
2	0089731	Filter assembly (includes items 3,4,5,6)
3	0043590	Spring
4	0089694	Seal, nylon
5	0089692	Housing filter
6	0089959	Filter
7	0293303	Guide, hose
8	0154782	Tip, .011 (oil based materials)
	0154783	Tip, .013 (oil based , latex paints and stains)
	0154784	Tip, .015 (extra thick materials)
9	0154680	Tip, body
10	0154693	Seal kit

NOTE: Part numbers may change without notice due to improvements and modifications.

FRANÇAIS • PISTOLET G-06

NOTA: Ce pistolet est utilisé pour les modèles CW. Si vous avez un modèle EX, consultez le manuel qui accompagne votre pistolet G-09 pour obtenir les numéros de pièces.

ARTICLE	No DE PIÈCE	DESCRIPTION
1	0293004	Ensemble de pistolet G-06 (comprend les articles 2 à 7)
2	0089731	Ensemble de filtre (comprend les articles 3, 4, 5 et 6)
3	0043590	Ressort
4	0089694	Joint d'étanchéité en nylon
5	0089692	Filtre de boîtier
6	0089959	Filtre
7	0293303	Guide de tuyau
8	0154782	Tête, 0,011 (pour peintures à huile)
	0154783	Tête, 0,013 (pour peintures à huile, peintures au latex et teintures)
	0154784	Tête, 0,015 (pour matériaux particulièrement épais)
9	0154680	Corps de tête
10	0154693	Ensemble de joint d'étanchéité

NOTA: Les numéros de pièces peuvent être changés sans avis, en raison d'améliorations ou de modifications.

ESPAÑOL • G-06 PISTOLA DE ATOMIZACIÓN

NOTA: Esta pistola se usa con los modelos CW. Si usted tiene un modelo EX, consulte el manual que viene con su pistola de atomización G-09 para ver los números de las piezas.

ARTÍCULO	# PIEZA	DESCRIPCIÓN
1	0293004	G-06 conjunto de la pistola (incluye los artículos del 2 al 7)
2	0089731	Conjunto del filtro (incluye los artículos 3,4,5 y 6)
3	0043590	Resorte
4	0089694	Sello, Nailon
5	0089692	Filtro de la caja
6	0089959	Filtro
7	0293303	Guía, manguera
8	0154782	TBoquilla, .011 (materiales a base de aceite)
	0154783	Boquilla, .013 (pinturas a base de aceite, de látex y tintes)
	0154784	Boquilla, .015 (materiales demasiado espesos)
9	0154680	Boquilla, mango
10	0154693	Juego para sellar

NOTA: Los números de las piezas pueden cambiar sin aviso debido a mejoras o modificaciones.