

TROUBLESHOOTING

Problem

Cause

Remedy

The sprayer does not start up.

1. The sprayer is not plugged in.
2. The ON/OFF switch is set to OFF.
3. A fuse is blown in the sprayer.
4. Low or no voltage is coming from the wall plug.
5. The sprayer was turned off while still under pressure.
6. The extension cord is damaged or has too low a capacity.
7. The thermal overload on the sprayer is tripped.
8. There is a problem with the motor.

1. Plug the sprayer in.
2. Turn the ON/OFF switch to ON.
3. Replace the blown fuse with the proper replacement.
4. Properly test the power supply voltage.
5. Turn the PRIME/SPRAY knob to PRIME.
6. Replace the extension cord.
7. Allow the motor to cool and move the sprayer to a cooler spot.
8. Take the sprayer to a Wagner Authorized Service Center.

The sprayer starts up but does not draw in paint when the PRIME/SPRAY knob is set to PRIME.

1. The unit will not prime properly or has lost prime.
2. The paint bucket is empty or the suction tube is not totally immersed in the paint.
3. The suction filter is clogged.
4. The suction tube is loose at the inlet valve.
5. The inlet valve is stuck.
6. The outlet valve is stuck.
7. The PRIME/SPRAY valve is plugged.
8. The inlet valve is worn or damaged.
9. There is a problem with the diaphragm.
10. The hydraulic oil level is low or empty.

1. Try to prime the unit again.
2. Immerse the suction tube in paint.
3. Clean the suction set filter.
4. Clean the tube connection and tighten it securely.
5. Clean the inlet valve.
6. Clean the outlet valve and replace any worn parts.
7. Take the sprayer to a Wagner Authorized Service Center.
8. Replace the inlet valve.
9. Take the sprayer to a Wagner Authorized Service Center.
10. Take the sprayer to a Wagner Authorized Service Center.

The sprayer draws up paint but the pressure drops when the gun is triggered.

1. The spray tip is worn.
2. The suction set filter is clogged.
3. The gun or spray tip filter is plugged.
4. The paint is too heavy or coarse.
5. The outlet valve assembly is dirty or worn.
6. The inlet valve assembly is damaged or worn.

1. Replace the spray tip with a new tip.
2. Clean the suction set filter.
3. Clean or replace the proper filter. Always keep extra filters on hand.
4. Thin or strain the paint.
5. Clean or replace the outlet valve assembly.
6. Replace the inlet valve.

The spray gun will not shut off.

1. The inlet or outlet valve ball or ball seat is worn.
2. Foreign matter or paint has built up between the ball and the seat.

1. Take the sprayer to a Wagner Authorized Service Center.
2. Take the sprayer to a Wagner Authorized Service Center.

The spray gun leaks.

1. Internal parts of the gun are worn or dirty.

1. Take the sprayer to a Wagner Authorized Service Center.

The tip assembly leaks.

1. The tip was assembled incorrectly.
2. A seal is worn.

1. Check the tip assembly and assemble properly.
2. Replace the seal.

The spray gun will not spray.

1. The spray tip, the gun filter or the tip filter is plugged.
2. The spray tip is in the CLEAN position.

1. Clean the spray tip, gun filter or tip filter.
2. Put the tip in the SPRAY position.

The paint pattern is tailing.

1. The pressure is set too low.
2. The gun, the tip, or the suction filter is plugged.
3. The suction tube is loose at the inlet valve.
4. The tip is worn.
5. The paint is too thick.

1. Increase the pressure.
2. Clean the filters.
3. Tighten the suction tube fitting.
4. Replace the spray tip.
5. Thin the paint.

The thermal overload tripped and shut off the sprayer.

1. The motor overheated.
2. The extension cord is too long or is too small a gauge.
3. Paint has built up on the motor.
4. The motor was started while the sprayer was under pressure.
5. The sprayer was sitting in the hot sun.

1. Allow to cool for 30 minutes.
2. Allow to cool for 30 minutes and replace the extension cord with a shorter extension or a thicker gauge cord.
3. Clean the paint from the motor.
4. Restart the sprayer in the PRIME mode.
5. Move the sprayer out of the sun.

NOTE: When the PRIME SPRAY valve is on SPRAY (I⁺) and there is flow through the return tube, remove the PRIME/SPRAY valve and clean or replace IT.

NOTE: The electric motor should always be kept clean and dry. Paint acts as an insulator. Too much paint on the motor will cause the motor to overheat.

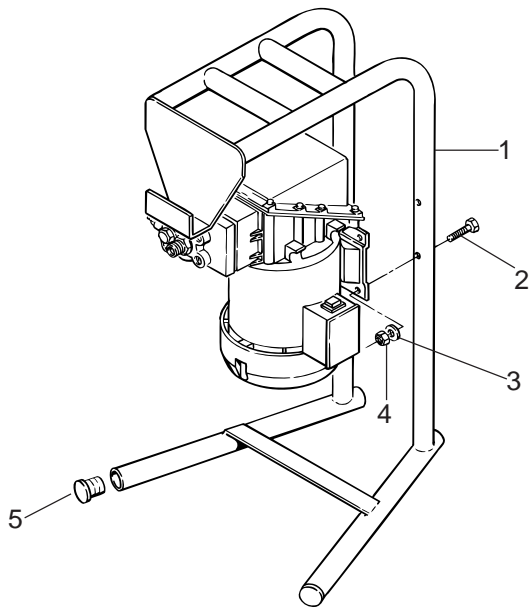

Parts Diagram – Final Assembly

ITEM	PART NO.	DESCRIPTION	QTY.
1	0270590	Stand Weldment	1
2	9810107	Screw, 5/16" x 1-3/4"	4
3	9821505	Washer, 5/16"	4
4	9810197	Nut, 5/16"	4
5	0294635	Plug, Leg	2

ACCESSORIES

PART NO.	DESCRIPTION
0270192	Hose, 25' X 1/4" Grounded
0093896	Hose Connector
0149018	G-9 Gun
0149017	G-10 Gun
0089731	Gun Filter Assembly
0154675	Gun Filters, Medium/Fine
0093820	Tip, Adjustable
0154681	Tip, Reversible (light) Stains
0154682	Tip, Reversible (Medium), Enamel
0154683	Tip, Reversible (heavy), Latex
0154693	Kit, Repair, Reversible Tip
0088009	Oil, Hydraulic (quart)
0088010	Oil, Hydraulic (gallon)

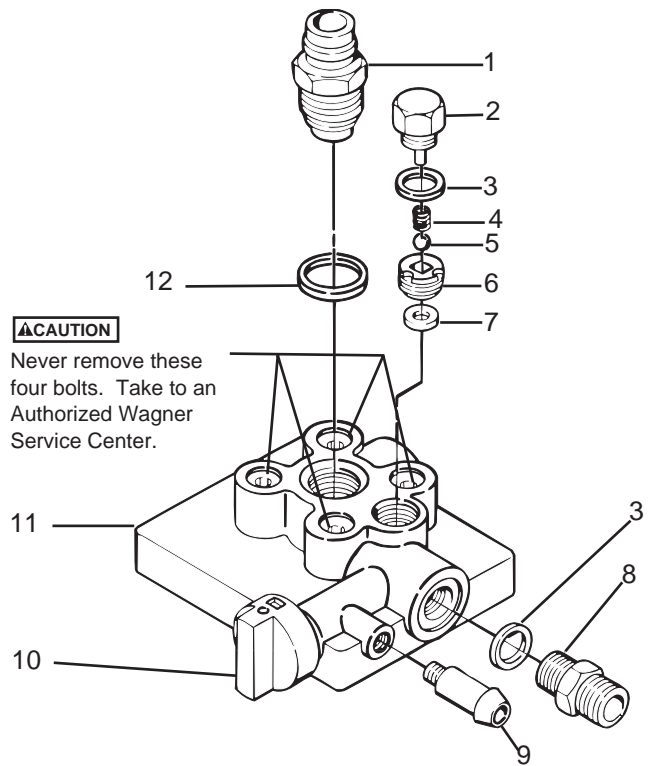

Parts Diagram - Paint Pump Assembly

ITEM	PART NO.	DESCRIPTION	QTY.
1	0270240	Valve, inlet assembly (includes item 12)	1
2	0270241	Cap, outlet assembly	1
3	9970103	Washer, sealing, copper	2
4	0047485	Spring, outlet	1
5	0093635	Ball, 6mm, carbide	1
6	0090348	Seat, ball, outlet assembly	1
7	0089494	Seal, outlet	1
8	0270551	Fitting, outlet	1
9	0088715	Fitting, return tube	1
10	0288748	Knob	1
11	0270200	Paint pump with valve	1
12	0089482	Washer, sealing, nylon	1
	0288172	Repair kit	1
		(replaces both holder and seat)	

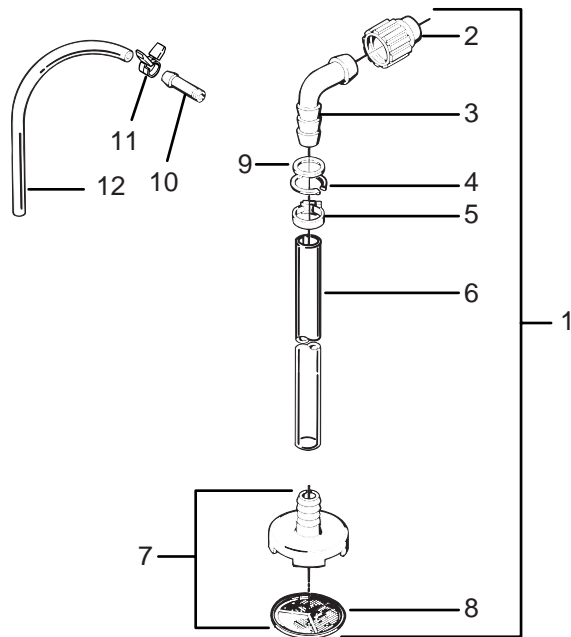

**Parts Diagram – Suction Set Assembly
0270174**

ITEM	PART NO.	DESCRIPTION	QTY.
1	0270133	Suction tube assembly 1 (Includes Items 2 through 10)	1
2	0090622	Nut, suction	1
3	0281314	Elbow, adapter, 3/4" x 1"	1
4	0088931	Ring, snap	1
5	0089882	Clamp	1
6	0270360	Hose, suction	1
7	0270162	Filter housing and filter	1
8	0270369	Filter	1
9	0090621	Washer	1
10	0088715	Fitting, return hose	1
11	0327226	Clamp	1
12	0270363	Tubing, return	1

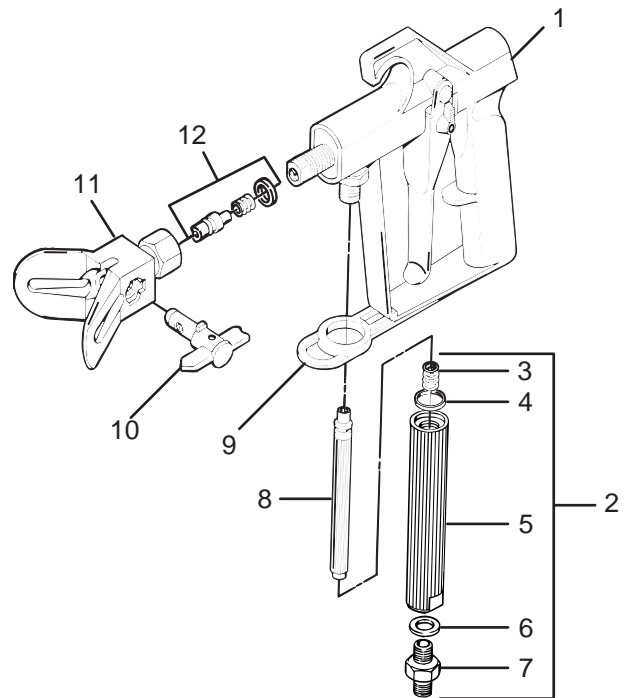

Parts Diagram - G-06 Spray Gun

ITEM	PART NO.	DESCRIPTION
1	0293004	G-06 gun assembly (includes items 2 through 7)
2	0089731	Filter assembly (includes items 3,4,5,6)
3	0043590	Spring
4	0089694	Seal, nylon
5	0089692	Housing filter
6	0043260	Washer
7	0089693	Fitting
8	0089959	Filter
9	0293303	Guide, hose
10	0154782	Tip, .011 (oil based materials)
	0154783	Tip, .013 (oil based , latex paints and stains)
	0154784	Tip, .015 (extra thick materials)
11	0154680	Tip, body
12	0154693	Seal kit

NOTE: Part numbers may change without notice due to improvements and modifications.