



TENSIONED EXECUTIVE ELECTROL®

Automatic Electric Projection Screen Model

SPECIFICATION DATA

DA-LITE SCREEN COMPANY, INC.
 3100 North Detroit Street
 Post Office Box 137
 Warsaw, Indiana 46581-0137
 Phone: 574-267-8101
 800-622-3737
 Fax: 574-267-7804
 Toll Free Fax: 877-325-4832
 www.da-lite.com
 e-mail: info@da-lite.com

SUGGESTED SPECIFICATIONS: _____ projection screen(s), _____ (H) x _____ (W), electrically operated 120 volt (60 Hz) not more than 2.2 amp. Three wire quick reversal motor especially designed for the purpose, to be ball bearing and oiled for life. With automatic thermal overload cut-out and integral interlocking gears. To have pre-set but adjustable limit switches to automatically stop screen surface in the "down" position. Stop action to be positive to prevent coasting. The roller to be of rigid metal at least 3" in diameter and mounted on two heavy duty brackets equipped with self-aligning bearings. Screen surface to be seamless, flame retardant and mildew resistant vinyl with black masking borders standard. Each side of the fabric to have tab guide cable system to maintain even lateral tension and hold surface flat. Custom slat bar with added weight maintains vertical tension on the screen surface. The ends of the slat to be protected by heavy duty plastic caps enclosing a preset adjustable mechanism for screen tensioning. Case to be of wood, with double top for extra rigidity and strength. Motor compartment to be metal lined. A section of the bottom of the case shall be equipped with hinges and connected to the drive mechanism so that it opens and closes automatically with the lowering and raising of the screen surface. The door will lift to the closed position where a micro switch shall cut off the electrical current to the motor. Balance of the bottom panel shall be pegged to manual opening to provide access. Hinges shall be mounted to allow matching of the bottom panel to the ceiling. **(Specify Type 1 and 2 or Type 3 hinge, as required.)** Case to be finished with a black primer coat, ready to accept final finish by others. To be complete with three position control switch with cover plate. Screen to be listed by Underwriters' Laboratories and CSA.



All viewing surfaces will be seamless.

All viewing surfaces are standard with black backing except Da-Tex® and Dual Vision.

Audio Vision, High Contrast Audio Vision and High Contrast Cinema Perf available in sizes up to 87" x 116" in Video Format and 78" x 139" in HDTV Format.

VIDEO (NTSC 4:3) FORMAT DIMENSIONS

Viewing Area		Nominal Diagonal		*Overall Length of Case		Approx. Ship. Wt.	
H x W	Cm	In.	Cm	In.	Cm	Lbs.	Kg
43" x 57"	109 x 145	72"	183	92 ³ / ₄ "	236	156	70.8
50" x 67"	127 x 170	84"	213	103 ³ / ₄ "	264	183	83.0
60" x 80"	152 x 203	100"	254	117 ³ / ₄ "	299	211	95.7
69" x 92"	175 x 234	120"	305	131 ³ / ₄ "	335	244	110.7
87" x 116"	221 x 295	150"	381	158 ³ / ₄ "	403	279	126.6
108" x 144"	274 x 366	180"	457	183 ³ / ₄ "	467	323	146.5
120" x 160"	305 x 406	200"	508	200 ³ / ₄ "	510	353	160.1

HDTV (16:9) FORMAT DIMENSIONS

Viewing Area		Nominal Diagonal		*Overall Length of Case		Approx. Ship. Wt.	
H x W	Cm	In.	Cm	In.	Cm	Lbs.	Kg
45" x 80"	114 x 203	92"	234	116 ¹ / ₄ "	295	211	95.7
52" x 92"	132 x 234	106"	269	128 ³ / ₄ "	327	244	110.7
54" x 96"	137 x 244	110"	279	133 ³ / ₄ "	338	250	113.4
58" x 104"	147 x 264	119"	302	141 ³ / ₄ "	360	261	118.4
65" x 116"	165 x 295	133"	338	154 ³ / ₄ "	393	279	126.6
78" x 139"	198 x 353	159"	404	179 ³ / ₄ "	457	300	136.1

SQUARE FORMAT DIMENSIONS

Viewing Area		*Overall Length of Case		Approx. Ship. Wt.	
H x W	Cm	In.	Cm	Lbs.	Kg
50" x 50"	127 x 127	86 ³ / ₄ "	220	140	63.5
60" x 60"	152 x 152	97 ³ / ₄ "	248	155	70.3
70" x 70"	178 x 178	109 ¹ / ₄ "	277	183	83.0
84" x 84"	213 x 213	125 ³ / ₄ "	319	211	95.7
6' x 8'	183 x 244	135 ³ / ₄ "	345	244	110.7
8' x 8'	244 x 244	139 ¹ / ₄ "	354	244	110.7
7' x 9'	213 x 274	149 ³ / ₄ "	380	267	120.2
9' x 9'	274 x 274	148 ¹ / ₄ "	377	267	120.2
8' x 10'	244 x 305	163 ¹ / ₄ "	415	279	126.6
10' x 10'	305 x 305	160 ¹ / ₄ "	407	279	126.6
9' x 12'	274 x 366	183 ³ / ₄ "	467	323	146.5
12' x 12'	366 x 366	193 ¹ / ₄ "	491	328	148.8

*Add 7" to overall length for mounting brackets.

All screens standard with 12" black drop at the top.

Extra drop may alter case dimensions. Contact Da-Lite for details.

Overall case length dimensions ±¹/₄".

Specifications subject to change without notice.

Detailed dimensional drawings, wiring diagrams and installation instructions available upon request.

Custom formats and sizes available upon request.

WHEN ORDERING, MARK APPROPRIATE SELECTIONS:

Select size from charts on the other side.

Select method of installation:

- Type 1 and 2 – Offset or Flush Mounting.
- Type 3 – Extended Mounting.

Select viewing surface:

- Da-Mat®
- Audio Vision
- High Contrast Da-Mat®
- High Contrast Audio Vision
- Dual Vision
- Pearlescent
- Cinema Vision
- High Contrast Cinema Vision
- High Contrast Cinema Perf
- Da-TeX® (Rear)

Options:

- Single motor Low Voltage Control (LVC) - external.
- Wireless Remote Control for LVC.
 - Radio Frequency Remote
 - Radio Frequency Range Extender available
 - Infrared Remote
- Key Locking Cover Plate for 120V or LVC Switch.
- Key Operated Switch for 120V only (NOTE: Cannot be used with LVC).
- 220 Volt (50 Hz) motor.
- Video Projector Interface Control - external.
- External SCB-100 - RS-232 Serial Control Board
 - NET-100 Ethernet-Serial Adapter
- White box (black standard).
- White doors (brushed aluminum standard).

Project: _____

Architect: _____

Phone: _____

Contractor: _____

Phone: _____

Supervisor: _____

Phone: _____

Supplier: _____

Date: _____

Revised: _____

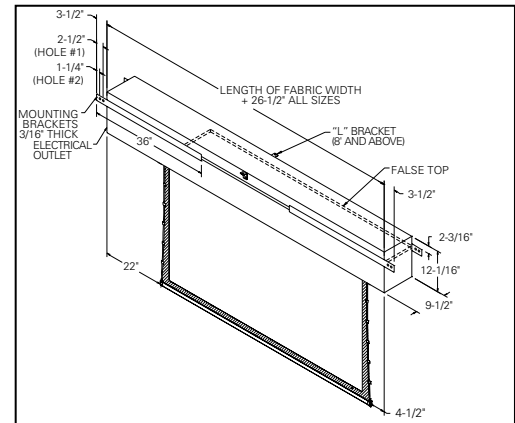

TENSIONED EXECUTIVE ELECTROL®

**SUGGESTED METHODS FOR INSTALLATION
ACCORDING TO CEILING TYPE**

TYPE 1 & 2

Offset mounting, recessed above ceiling, for plaster, dry wall or paneling. Door painted same finish as ceiling.

INCLUDING MOUNTING BRACKETS

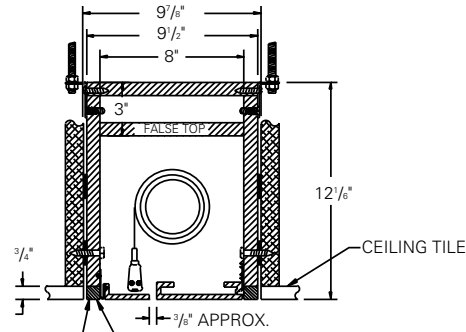

NOTE: Paint the same as doors and ceiling or remove and replace with ceiling tile.

TYPE 1 & 2

Allow 1/8" min. clearance all around surface door.

Flush mounting, recessed above ceiling. For use with 1/2" max. paneling or installation in existing ceiling using molding around door.

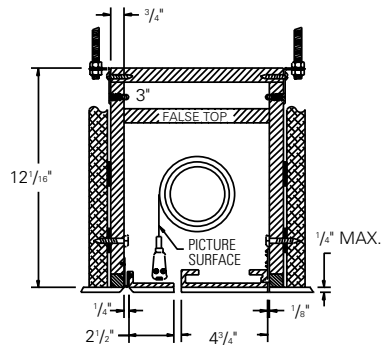

TYPE 3

Allow 1/8" min. clearance all around surface door.

Extended mounting, recessed above ceiling. For use with acoustical or other ceiling tile 3/4" thick laid over door.

