



# TENSIONED PROFESSIONAL ELECTROL®

Automatic Electric Projection Screen Model

## SPECIFICATION DATA

DA-LITE SCREEN COMPANY, INC.  
3100 North Detroit Street  
Post Office Box 137  
Warsaw, Indiana 46581-0137  
Phone: 574-267-8101  
800-622-3737  
Fax: 574-267-7804  
Toll Free Fax: 877-325-4832  
www.da-lite.com  
e-mail: info@da-lite.com

**SUGGESTED SPECIFICATIONS:** \_\_\_\_\_ projection screen(s), \_\_\_\_\_ (H) x \_\_\_\_\_ (W), electrically operated 120 volt (60Hz) not more than 2.4 amp. Shall have specially designed motor mounted inside the roller, to be three wire with ground quick reversal type, oiled for life, with automatic thermal overload cut-out, integral gears, capacitor and an electric brake to prevent coasting. To have pre-set but adjustable limit switches to automatically stop picture surface in the "up" and "down" positions. The roller to be of 4½" diameter aluminum. Roller to be mounted in one heavy duty bracket equipped with self-aligning bearing. Motor to be secured to the case with a steel motor mount bracket. Screen fabric to be flame retardant and mildew resistant vinyl with black masking borders standard. Each side of fabric to have a tab guide cable system to maintain even lateral tension and hold surface flat. Bottom of fabric to be inserted into a custom aluminum slat bar with added weight to provide vertical tension on the screen surface. The ends of the slat to be protected by heavy duty plastic caps enclosing a preset adjustable mechanism for screen tensioning. Case to be of wood, with double top for extra rigidity and strength. Case to be finished with a black primer coat, ready to accept final finish by others, heavy metal brackets shall be supplied for mounting screen to ceiling or wall. To be complete with 3 position control switch with cover plate. Screen to be listed by Underwriter's Laboratories.

All viewing surfaces will be seamless.

All viewing surfaces are standard with black backing except Da-Tex® and Dual Vision.

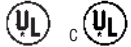

### VIDEO (NTSC 4:3) FORMAT DIMENSIONS

Viewing Area		Nominal Diagonal		Overall Length of Case		Approx. Ship. Wt.	
H x W	Cm	In.	Cm	In.	Cm	Lbs.	Kg
108" x 144"	274 x 366	180"	457	167¼"	425	301	136.5
120" x 160"	305 x 406	200"	508	184¾"	469	306	138.8
126" x 168"	320 x 427	210"	533	193¾"	492	315	142.9
132" x 176"	335 x 447	220"	559	202¾"	515	320	145.2
144" x 192"	366 x 488	240"	610	220¼"	559	380	172.4
162" x 216"	411 x 549	270"	686	245¾"	624	430	195.5

### HDTV (16:9) FORMAT DIMENSIONS

Viewing Area		Nominal Diagonal		Overall Length of Case		Approx. Ship. Wt.	
H x W	Cm	In.	Cm	In.	Cm	Lbs.	Kg
92" x 164"	234 x 417	188"	478	185¾"	472	315	142.9
108" x 192"	274 x 488	220"	559	215¼"	547	350	172.4
121" x 216"	307 x 549	247"	627	241¼"	613	430	195.5
135" x 240"	343 x 610	275"	699	267¼"	679	810	368.2
146" x 260"	372 x 660	298"	757	288¾"	733	875	397.7

### SQUARE FORMAT DIMENSIONS

Sizes		Overall Length of Case		Approx. Ship. Wt.	
H x W	Cm	In.	Cm	Lbs.	Kg
9' x 12'	274 x 366	167¼"	425	301	136.5
12' x 12'	366 x 366	172¼"	438	311	141.1
10'6" x 14'	320 x 427	193¾"	492	315	142.9
14' x 14'	427 x 427	200¾"	510	335	152.0
12' x 16'	366 x 488	220¼"	559	380	172.4

All screens standard with 12" black drop at the top (except 270" diagonal).

Extra drop may alter case dimensions. Contact Da-Lite for details.

Overall case length dimensions ±¼".

Detail dimensional drawings, wiring diagrams and installation instructions available upon request.

Specifications subject to change without notice.

Custom formats and sizes available upon request.

**WHEN ORDERING, MARK APPROPRIATE SELECTIONS:**

Select size from charts on the other side.

**Select viewing surface:**

- Da-Mat®
- High Contrast Da-Mat®
- Cinema Vision
- High Contrast Cinema Vision
- Pearlescent
- Da-Tex® (Rear)
- Dual Vision

**Options:**

- Single Motor Low Voltage Control System (LVC) - external.
- Wireless Remote Control for LVC.
  - Radio Frequency Remote.
    - Radio Frequency Range Extender available
  - Infrared Remote.
- Key Locking Cover Plate for 120V or LVC Switch.
- Key Operated Switch for 120V only (NOTE: Cannot be used with LVC).
- 220 Volt (50 Hz) Motor.
- Video Projector Interface Control - external.
- External SCB-100 - RS-232 Serial Control Board.
  - NET-100 Ethernet-Serial Adapter.
- White box (black standard).

Project: \_\_\_\_\_

Architect: \_\_\_\_\_

Phone: \_\_\_\_\_

Contractor: \_\_\_\_\_

Phone: \_\_\_\_\_

Supervisor: \_\_\_\_\_

Phone: \_\_\_\_\_

Supplier: \_\_\_\_\_

Date: \_\_\_\_\_

Revised: \_\_\_\_\_

## TENSIONED PROFESSIONAL ELECTROL®

### SUGGESTED METHODS OF INSTALLATION

**CEILING TYPE HANGER**

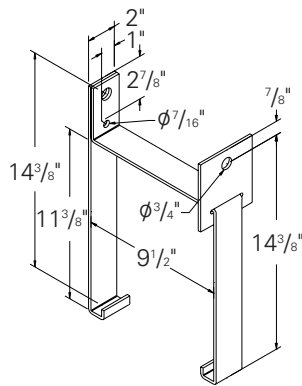
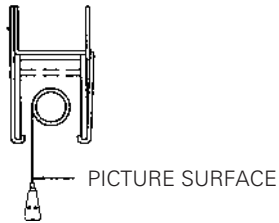

**WALL TYPE HANGER**

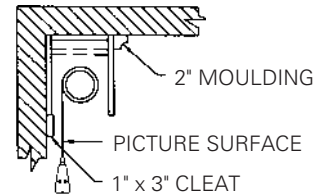
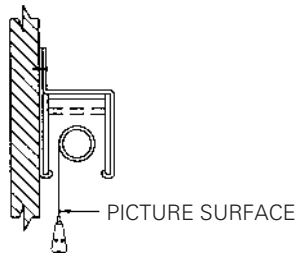

**CEILING MOUNT WITHOUT HANGERS**

Screen case is placed flush with the wall and ceiling and held in position by moulding securely attached to the wall.

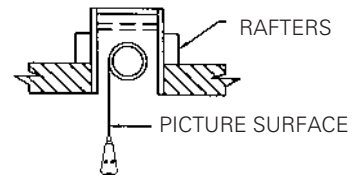

**RECESSED ABOVE CEILING**

Other methods of installation will suggest themselves in new buildings where it would be an easy matter to provide a recess for the screen to conceal it when not in use.  
Do not seal in—allow access.

**WALL OR CEILING MOUNT WITH HANGERS**

Wall type hangers and ceiling type hangers are standard equipment. One set is supplied with each screen. Useful for recessed installations.

**FOR EXPOSED INSTALLATION**

If the screen is to be mounted in an exposed position, it may be covered with finished plywood, veneer, paneling, plastic wall covering or a valance.

