



# BOARDROOM ELECTROL®

Automatic Electric Projection Screen Model

## SPECIFICATION DATA

DA-LITE SCREEN COMPANY, INC.  
 3100 North Detroit Street  
 Post Office Box 137  
 Warsaw, Indiana 46581-0137  
 Phone: 574-267-8101  
 800-622-3737  
 Fax: 574-267-7804  
 Toll Free Fax: 877-325-4832  
 www.da-lite.com  
 e-mail: info@da-lite.com

**SUGGESTED SPECIFICATIONS:** \_\_\_\_\_ projection screen(s), \_\_\_\_\_ (H) x \_\_\_\_\_ (W), electrically operated 120 volt (60Hz), not more than 2.4 amp. Shall have specially designed motor mounted inside the roller, to be three wire with ground, quick reversal type, oiled for life, with automatic thermal overload cutout, integral gears, capacitor and an electric brake to prevent coasting. To have preset but adjustable limit switches to automatically stop picture surface in the "down" position. The roller to be of rigid metal. Screen fabric to be flame retardant and mildew resistant fiberglass with black masking borders standard. Bottom of fabric shall be formed into a pocket holding a metal rod. The ends of the rod shall be protected by heavy-duty plastic caps. Case to be of wood with metal-lined wiring compartment. A section of the bottom of the case shall be a door equipped with hinges so that it opens and closes automatically with the lowering and raising of the picture surface. When the picture surface is being lowered, the door shall drop open by gravity. When the picture surface is being raised, the two ends of the slat in the bottom pocket of the screen fabric shall engage two hooks on the door to lift it to the closed position where the door will engage a micro switch that will cut off the electrical current to the motor. The balance of the bottom of the case shall be a second hinged door with manual opening to provide access. Hinges shall be mounted to allow matching of the doors to the ceiling. Case to be finished with a black primer coat, ready to accept final finish by others. To be complete with three position control switch with cover plate. Screen to be listed by Underwriters' Laboratories.

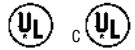

**Matte White:** Seamless in all sizes.

**Video Spectra 1.5:** Available in sizes where both dimensions do not exceed 8'.

**High Power®:** Available in sizes up to 9'x 12'. Horizontal seam required when both dimensions exceed 6'.

### VIDEO (NTSC 4:3) FORMAT DIMENSIONS (2" standard black drop at top)

Viewing Area		Nominal Diagonal		*Overall Length of Case		Approx. Ship. Wt.	
H x W	Cm	In.	Cm	In.	Cm	Lbs.	Kg
43" x 57"	109 x 145	72"	183	73 1/2"	187	72	32.7
50" x 67"	127 x 170	84"	213	83 1/2"	212	79	35.8
57" x 77"	145 x 196	96"	244	97 1/2"	248	86	39.0
60" x 80"	152 x 203	100"	254	97 1/2"	248	91	41.3
69" x 92"	175 x 234	120"	305	109 1/2"	278	106	48.1
87" x 116"	221 x 295	150"	381	133 1/2"	339	129	58.5
105" x 140"	267 x 356	180"	457	157 1/2"	400	137	62.1
120" x 160"	305 x 406	200"	508	177 1/2"	441	154	69.9

### HDTV (16:9) FORMAT DIMENSIONS (2" standard black drop at top)

Viewing Area		Nominal Diagonal		*Overall Length of Case		Approx. Ship. Wt.	
H x W	Cm	In.	Cm	In.	Cm	Lbs.	Kg
45" x 80"	114 x 203	92"	234	97 1/2"	248	91	41.3
52" x 92"	132 x 234	106"	269	109 1/2"	278	100	45.4
54" x 96"	137 x 244	110"	279	113 1/2"	288	105	47.6
58" x 104"	147 x 264	119"	302	121 1/2"	309	115	52.2
65" x 116"	165 x 295	133"	338	133 1/2"	339	119	54.0
78" x 139"	198 x 353	159"	404	157 1/2"	400	149	67.6
90" x 160"	229 x 406	184"	467	177 1/2"	451	154	70.0

### SQUARE FORMAT DIMENSIONS (screens with ^ have 2" standard black drop at top)

Sizes		*Overall Length of Case		Approx. Ship. Wt.	
H x W	Cm	In.	Cm	Lbs.	Kg
50" x 50"	127 x 127	63 1/2"	161	64	29.0
60" x 60"	152 x 152	73 1/2"	186	73	33.1
70" x 70"	178 x 178	83 1/2"	211	83	37.7
84" x 84"	213 x 213	97 1/2"	248	95	43.1
6' x 8' ^	183 x 244	109 1/2"	278	101	45.8
8' x 8'	244 x 244	109 1/2"	278	105	47.6
7' x 9' ^	213 x 274	121 1/2"	309	112	50.1
9' x 9' ^	274 x 274	121 1/2"	309	119	54.0
8' x 10' ^	244 x 305	133 1/2"	339	130	59.0
10' x 10' ^	305 x 305	133 1/2"	339	134	60.8
9' x 12' ^	274 x 366	157 1/2"	400	137	62.1
12' x 12'	366 x 366	157 1/2"	400	159	72.1

\* Add 3" to overall length of case for mounting brackets.

Overall case length dimensions ± 1/4".

Detail dimensional drawings, wiring diagrams and installation instructions available upon request.

Specifications subject to change without notice.

Custom formats and sizes available upon request.

**WHEN ORDERING, MARK APPROPRIATE SELECTIONS:**

Select size from charts above.

**Select viewing surface:**

- Matte White
- High Power
- Video Spectra 1.5
- Greenguard® and Greenguard® Children and Schools Certified.

**Optional Accessories:**

- Extra Drop available to lower picture area more than normal. Specify total drop at top \_\_\_\_ (black or white) or at bottom \_\_\_\_ (black or white). 13' maximum total surface height including picture area.
- Single Motor Low Voltage Control (LVC) - external.
- Wireless Remote Control for LVC.
  - Radio Frequency Remote.
  - Radio Frequency Range Extender available
  - Infrared Remote.
- Key Locking Cover Plate for 120V or LVC Switch.
- Silent Motor for sizes up to 9'x12'.
- Key Operated Switch for 120V only (NOTE: Cannot be used with LVC).
- No Borders (Black masking borders standard).

Project: \_\_\_\_\_

Architect: \_\_\_\_\_

Phone: \_\_\_\_\_

Contractor: \_\_\_\_\_

Phone: \_\_\_\_\_

Supervisor: \_\_\_\_\_

Phone: \_\_\_\_\_

Supplier: \_\_\_\_\_

Date: \_\_\_\_\_

Revised: \_\_\_\_\_

- 220 Volt (50 Hz) Motor.
- Video Projector Interface Control - external.
- External SCB-100 - RS-232 Serial Control Board
  - NET-100 Ethernet-Serial Adapter
- White doors (brushed aluminum standard).
- White box (black standard).

**BOARDROOM ELECTROL®**

**SUGGESTED METHODS OF INSTALLATION**

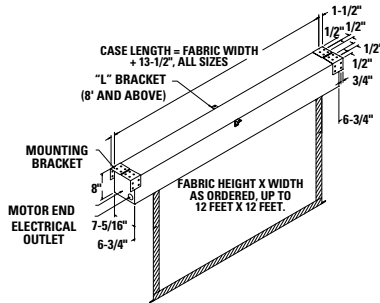

Select installation method according to ceiling type.

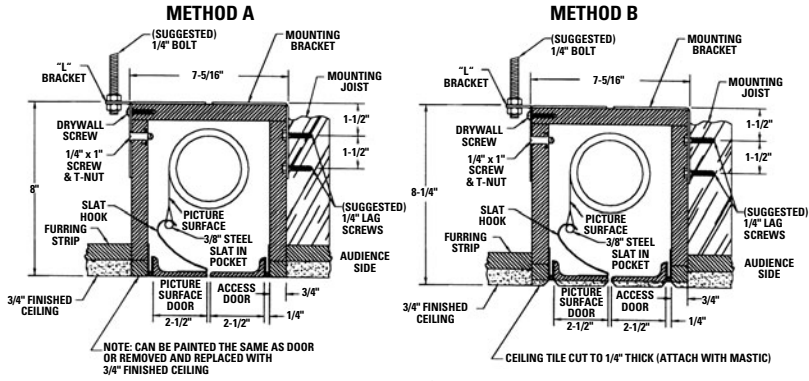

Offset mounting, recessed above ceiling. For plaster, dry wall, tile or paneling. Doors and bottom of case painted same finish as ceiling.

Offset mounting, recessed above ceiling. May be adapted for 3/4\"/>

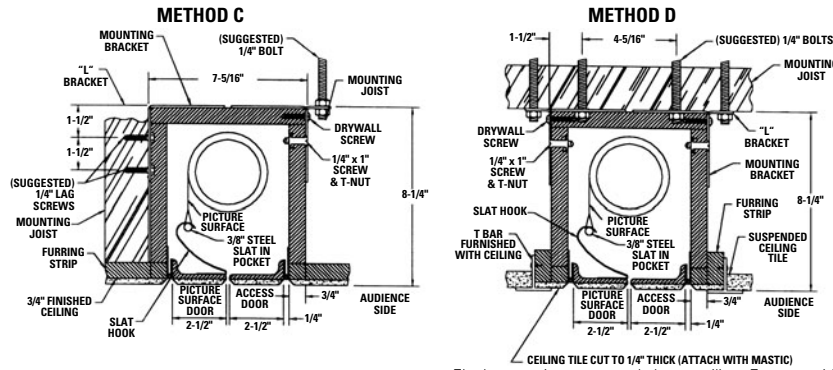

Flush mounting, recessed above ceiling. May be adapted for 1/4\"/>

Flush mounting, recessed above ceiling. For use with dropped ceiling. May also be adapted for use with acoustical or other ceiling 3/4\"/>