

# Installation/Operating Instructions Access XL Electric Projection Screen by Draper

US Patent Nos. 6,137,629;  
6,421,175; 6,532,109;  
6,816,308; 7,559,707

## ⚠ Caution

- ① Read instructions through completely before proceeding.
- ② Follow instructions carefully. Installation contrary to instructions invalidates warranty.
- ③ Pick up screen case from **ends only**. Picking case up at other points **will damage case and may damage fabric**.
- ④ To insure a safe installation, the **entire weight** of the unit **MUST BE** supported by outermost ceiling mounting brackets (those on ends). **Do not use intermediate brackets to lift or support the weight of the screen.**
- ⑤ **To eliminate the possibility of the case warping, outermost ceiling mounting brackets (those on ends) must be located centered above the interior roller mounting brackets (+/- 4").**
- ⑥ Entire bottom of screen case should be unobstructed to permit access to bottom panel for making electrical connections or servicing.
- ⑦ Screen should be installed level (using a carpenter's level).
- ⑧ Operating switch(es) packed separately in screen carton. Do not discard with packing material.
- ⑨ An appropriate disconnect device shall be provided as part of the building installation.
- ⑩ Screen operates on 110-120V, 60 Hz., with max 2.1 amp current draw.

**NOTE:** Screen has been thoroughly inspected and tested at factory and found to be operating properly prior to shipment.

*These instructions are meant as a guide only. They do not imply any responsibility on the part of the manufacturer for improper installation or faulty workmanship at the jobsite.*

## Hanging Screen

When locating viewing surface and checking clearance for screen operation, remember surface is centered in the length of the case. Regardless of mounting method used, the following points apply:

- ① Engage each ceiling mounting bracket with top of housing as shown below and tighten nuts. The outer two brackets should be centered above the location of the interior roller brackets (+/- 4"). The remaining two brackets should be equally spaced between the outermost brackets.
- ② Screen should be lifted into position **only by the outermost ceiling mounting brackets (those on ends)**. **Keep case level by lifting each end simultaneously to prevent surface damage. Never attempt to lift screen along its length.**
- ③ The **entire weight** of the unit **MUST BE** supported by the outermost mounting brackets to provide a secure installation (those on ends). **Do not use intermediate brackets to lift or support the weight of the screen.**
- ④ Screen should be positively and securely supported so that vibration or even abusive pulling on viewing surface will not weaken installation.
- ⑤ Installer must insure that fasteners used are of adequate strength and suitable for the mounting surface chosen. **Installer must also insure that ceiling structure is of adequate strength.** Supporting hardware (chains, cables, 3/8" rods, etc.) must be essentially vertical.
- ⑥ Entire bottom of case must be readily accessible after installation is complete.

### Typical Installation

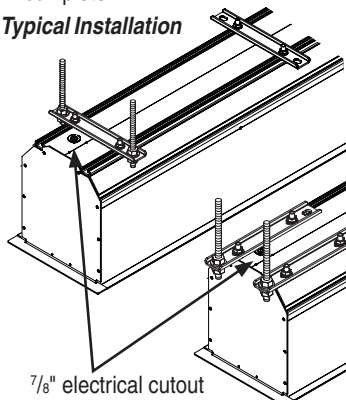

Slots along top of case permit brackets to be set at an angle

Case dimensions on page 3.

**Alternate Installation (additional set of brackets required but not included). Two intermediate brackets must be spaced evenly from ends.**

**Suitable for use in environmental air space in accordance with Section 300-22(c) of the National Electrical Code, and Sections 2-128, 12-010(3) and 12-100 of the Canadian Electrical Code, Part 1, CSA C22.1.**

# DRAPER®

411 S. Pearl St., Spiceland, IN 47385 USA ■ 765-987-7999  
www.draperinc.com ■ fax 765-987-7142  
Copyright © 2013 Draper Inc. Form AccessXL\_Inst13 Printed in U.S.A.

- ⑦ Front, back and top of case must be straight—not forced to warp or bow (see note 5 in caution box).
- ⑧ Do not use case to support adjacent sections of ceiling.
- ⑨ If case is painted on location, removal of roller/fabric assembly is recommended prior to painting. If not removed, slot on bottom of case should be shielded to protect viewing surface from paint splatters or overspray.
- ⑩ Do not seal unit in ceiling until electrical connections have been made and screen has been operated successfully.

## Electrical Connections

Screen operates on 110-120V, 60 Hz., with max 2.1 amp current draw. Junction box is located just above the bottom access panel at left end of screen (standard, right end may be specified). Remove the bottom access panel for access to the junction box cover (see Bottom Access Panel Removal instructions below). Remove four (4) hex head screws that secure the cover to the junction box to expose the red, black, and white pigtail leads and the green/yellow ground wire per wiring diagram on page 3. If optional low voltage control or video interface control is specified and factory installed, please refer to wiring diagrams on page 4.

Screen is shipped with internal wiring complete and control switch (es) fully boxed. Wire to connect screen to switch (es) and switch (es) to power supply should be furnished by installer. **Connections must be made in accordance with attached wiring diagram, and wiring must comply with national and local electrical codes.**

**⚠ All operating switches should be "off" before power is connected.**

Motor Type	Duty Cycle
506S2PA, 510S2PA, 515S2PA, 506S2 ILT2, 515S2 ILT2	1 minute on, 3 minutes off
525A2PA, 535A2PA, 535A2 ILT2	1 minute on, 10 minutes off

**NOTE: Excessive continuous operation may cause the motor to over heat. If this happens the motor will shut off until it cools to a normal operating temperature.**

## Shipping Brackets

If provided, remove shipping brackets by following Figure 2.

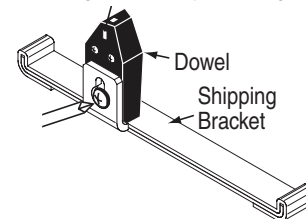

Series V

Figure 2

## Bottom Access Panel Installation/Removal

Removal and replacement of the bottom closure panel requires two people positioned about 5' from each end of the panel.

- ① Before removing bottom closure, you must first remove screws at each end of case and slide the closure clips inward, away from the outside of the case (see Fig. 3).

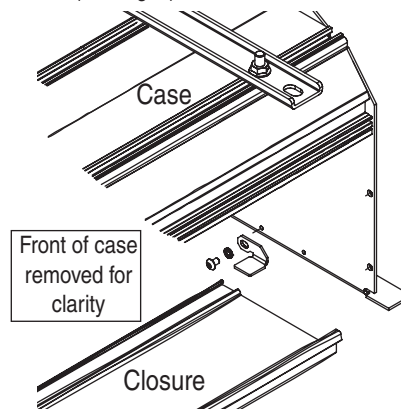

Figure 3

**Continued on next page**

*If you encounter any difficulties installing or servicing your Access XL screen, call your dealer or Draper, Inc., in Spiceland, Indiana, 765/987-7999 or fax 765/987-7142.*

- Disengage closure from extrusion inside the case. Rotate closure as shown in Fig. 4 and remove, holding it so the closure remains in this position and does not bow before placing it on a flat surface.

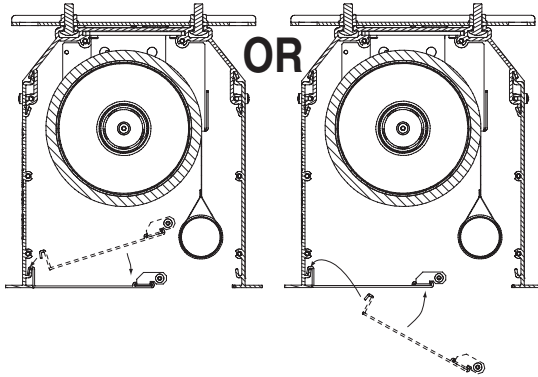
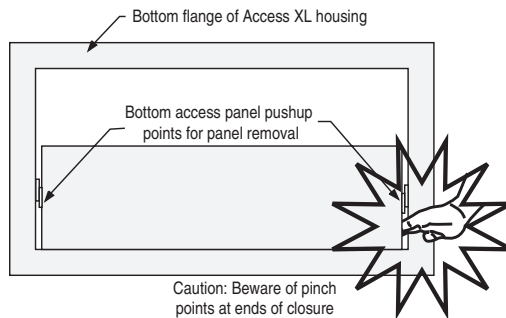

Figure 4



Access XL case as seen from below

**Accessory Access ACXLE & ACXLV Roller Installation**

Please note: When ordering a motor with built-in Low Voltage Controller, if the case ships separate from the "guts," the case includes the 25' cable and special low voltage switch.

- Remove the bottom access panel (see "Bottom Access Panel Installation/Removal" section above).
- The motor end mounting bracket has a metal bracket with snap ring for accepting motor head. The idler end mounting bracket has spherical ball bearings for accepting the idler pin. Both brackets have four set screws that will be used to tighten the brackets in place inside the case. Back out the four set screws in bracket until they are flush with top side of bracket, then remove the roller assembly from the shipping brackets, placing the roller assembly on a flat, clean surface (see Fig. 5).

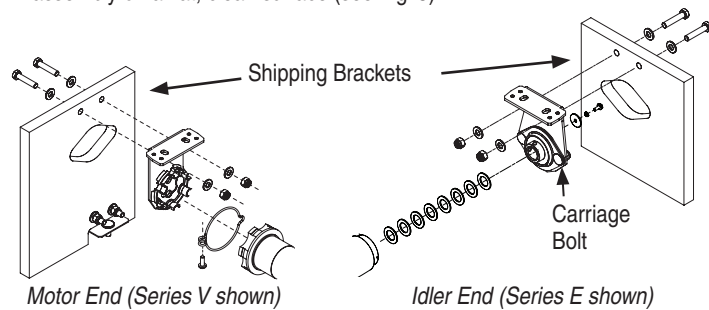

Figure 5

**Please Note: Do not lose the snap ring and screw from the motorized end, or the eight nylon washers, spring lock washer, fender washer and machine screw from the idler end. They are required for re-attaching the roller assembly to the brackets inside the case.**

- To engage the motor end bracket flange above the two channels in the top of the screen housing, rotate the bracket approximately 45° counter-clockwise to allow the top surface of the motor bracket to rest flat against the top inside of the housing. Rotating the bracket clockwise until it is engaged with the mounting channel, slide it along the length of the housing against the electrical junction box. Note: Set screw collar side of the bracket must point toward the center of the case.

**⚠ Caution: Do not allow the bracket to rotate and fall out of the channel.**

- Tighten all four set screws.

- Replace the eight Nylon Washers into the idler end of the roller assembly.
- Loosen the carriage bolts which attach the flange-mounted bearing to the idler end bracket just enough to allow the bushing some limited movement, which will help when installing the roller assembly.
- Rotate the bracket into the mounting channel located in the case top (when mounting the roller assembly into the case). Both the bracket flange and set screw collar side of the bearing must point toward the gudgeon assembly.
- Raise the roller/fabric assembly up into the screen housing and engage the head of the motor completely into the motor mounting bracket, making sure the snap ring engages with the motor and that the limit switch adjusting knobs are visible from the bottom of the screen housing (see Fig. 6).

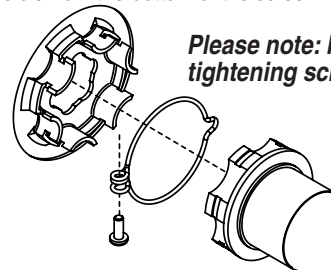

**Please note: Maximum torque for tightening screw is 5 lb-inches.**

Figure 6

**⚠ Caution: When placing the roller assembly into the case, be sure motor is fully re-seated in the bracket, and secure it carefully with the motor retaining spring and screw. Limit adjustment screws should be facing down to allow access to them.**

**⚠ Caution: Due to the weight of the roller assembly, this step requires at least two people to perform safely.**

- While supporting the idler end of the roller, slide the idler end mounting bracket toward the roller. Slide the bearing over the end of the shaft.
- ⚠ Caution: Do not allow bracket to rotate and fall out of channel!** Align the bracket into the housing and tighten all four of the set screws. Lock the roller assembly into place on the mounting bracket with the fender washer, spring lock washer and machine screw (see Fig. 7).

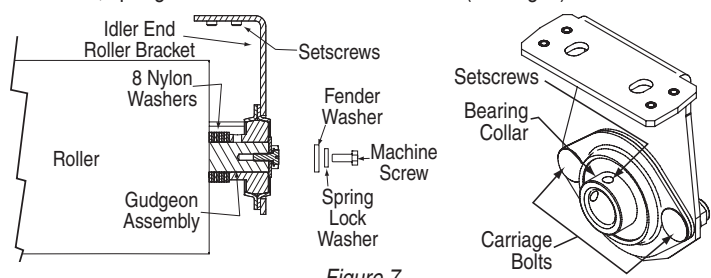

Figure 7

- Re-tighten the carriage bolts in the Idler-end Bracket Assembly so that the flange-mounted bearing is locked in place (see Fig. 5).
- Tighten the two set screws in the bearing collar.
- Connect electrical plug from motor to mating socket on junction box.
- Reinstall the bottom access panel as previously described (see Figs 3 & 4).

**Motorized Roller/Fabric Removal**

Reverse the instructions above "Motorized Roller/Fabric Installation" for removal of the unit.

**Operation**

When screen is first operated, **be cautious!** Cycle unit down and up several times to confirm satisfactory operation.

**110-120V SINGLE STATION CONTROL**—3-position UP-OFF-DOWN switch permits operation to be stopped at any point. Factory adjusted limit switches automatically stop screen when fully down or fully up.

**110-120V MULTIPLE STATION CONTROL**—Switches are similar in appearance to 110-120V Single Station Control. Screen stops when switch is released and may be restarted in either direction. Factory adjusted limit switches stop screen automatically when fully down or fully up.

**24V CONTROL**—Three-button UP-STOP-DOWN switches stop at any point desired, operate in any sequence. Factory adjusted limit switches automatically stop screen when fully down or fully up. Installer should incorporate an all-pole disconnect in the fixed wiring.

**110-120V & 12V VIDEO INTERFACE CONTROL**—Allows screen to be controlled by trigger signal (100 milliAmp minimum)—when the signal comes on, the screen descends automatically. Two versions: Model VIC115 integrates screen operation with a Draper video projector lift or a video projector or tuner with a 110-120V switched outlet. Model VIC12 interfaces with a 12V switched outlet. Both available with an override switch (VIC-OS), permitting independent operation.

**KEY OPERATED SWITCHING**—Two kinds of key-operated switches are optionally available with this unit. ① The key-operated power supply switch controls power to the screen and switches. When it is “off”, the switches will not operate screen. Key may be removed from the switch in either “on” or “off” position. ② A three-position key switch permits the screen to be operated directly by key. In this case, the screen’s operator must always have a key. **RS232/ETHERNET**—Serial communication and network communication optionally available with wall switches, RF or IR remote.

### Tab-Tension Adjustment Procedure for Access XL/Series V

Draper’s Tab-Tensioning System is factory-set; under normal circumstances field adjustment is not required. If you notice wrinkles, waves or other indications that tensioning cables need adjusting, follow these steps:

- ① Determine which side requires adjustment.
- ② Secure dowel with one hand.
- ⚠ **Caution: Don’t touch or bend viewing surface.**
- ③ Use Phillips-head screwdriver to push in spring-loaded adjustment screw. Slowly turn clockwise to tighten tension or counterclockwise to loosen tension. The screw adjusts in ¼ turn increments. Adjust only **one increment** (¼ turn) at a time.
- ④ If problem is not corrected, leave screen in position for 24 hours to allow surface material to stretch into position.
- ⑤ If problem still is not corrected, repeat steps 2 and 3.

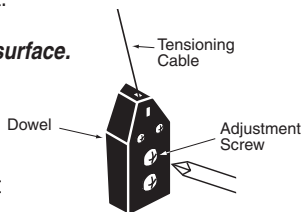

### Limit Adjustments (Standard Motor)

**Please Note: Screen limits are factory set for optimum performance of the screen. A procedure is outlined below for minor tweaks, but any adjustment of these limits may negatively affect the flatness of the screen surface and could also void the warranty. Please check with Draper prior to resetting screen limits.**

⚠ **CAUTION: Always be prepared to shut screen off manually when new adjustment is being tested. Screen may be severely damaged if viewing surface is allowed to run too far up or too far down.**  
 ⚠ **CAUTION: Be sure all switches are in “off” position before adjusting limit switches.**

The motor limit screws are normally located on the audience left of screen roller.

**\*\*Please Note: If the Access XL is “Right Hand Motor”, WHITE/DOWN and YELLOW/UP limit screws are reversed. See graphic below.**

#### “Down” Limit Adjustment

##### To Reduce Screen Drop

- ① Raise screen surface about 1' above desired setting and turn off.
- ② Turn the WHITE/DOWN limit screw clockwise (three screw turns = ½ roller revolution).
- ③ Test by running screen down and repeat steps 1 and 2 until desired position is reached.

##### To Increase Screen Drop

- ① Run screen to the down limit.
- ② With the down switch on, turn WHITE/DOWN limit screw counterclockwise (3 turns of screw equals ½ roller revolution) to increase drop. Screen will drop automatically for each turn.
- ③ Test by running screen up about 1' and back down to new down limit.
- ④ Repeat steps 2 and 3 until desired position is reached.

#### “Up” Limit Adjustment

##### Screen is Running Too Far Up

- ① Lower screen surface about 1' below desired setting and turn off.
- ② Turn YELLOW/UP limit screw clockwise (3 screw turns = ½ roller revolution).
- ③ Test by running screen up.
- ④ Repeat steps 1 through 3 until desired position is reached.

##### Screen Needs to Run Up More

- ① Run screen down about 1' and turn off.
  - ② With the up switch on, turn the YELLOW/UP limit screw counterclockwise (3 turns of screw equals ½ roller revolution). Screen will drop automatically for each turn.
  - ③ Repeat steps 1 and 2 until desired position is reached.
- CAUTION: Do NOT allow the dowel to wrap up over the roller when the screen is running up! This could damage the screen.**

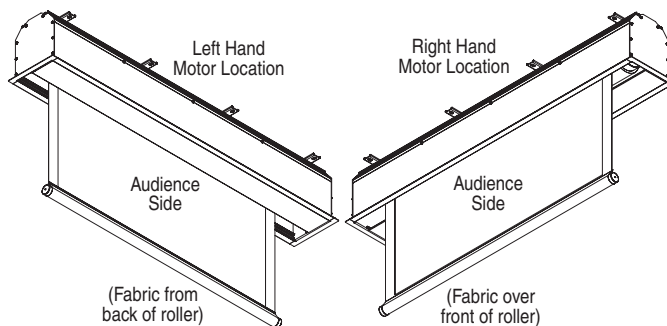

### Limit Adjustments (Built-in Low Voltage Motors)

**Please Note: Screen limits are factory set for optimum performance of the screen. A procedure is outlined below for minor tweaks, but any adjustment of these limits may negatively affect the flatness of the screen surface and could also void the warranty. Please check with Draper prior to resetting screen limits.**

⚠ **CAUTION: Always be prepared to shut screen off manually when new adjustment is being tested. Screen may be severely damaged if viewing surface is allowed to run too far up or too far down.**

⚠ **CAUTION: Be sure all switches are in “off” position before adjusting limit switches.**

**Please note: When ordering a motor with built-in Low Voltage Controller, if the case ships separate from the “guts,” the case includes the 25' cable and special low voltage switch.**

- ① Connect the ILT switch to the motor via the terminal blocks, or via the modular port using four conductor modular cable. When using modular cable, the cable connectors MUST NOT be crimped in reverse, as with standard telephone cable. (For Dry Contacts Wiring Diagram, see page 4.)
- ② Set the slide switch to the lower position. Press and hold the DOWN button on the switch to move the viewing surface to the desired lower limit. If the screen moves in the opposite direction, release the DOWN button and press and hold down the STOP button for four seconds. This will reverse the operation of the UP and DOWN switches.
- ③ Move slider switch into center position. Wait a couple of seconds.

**Please Note: If you move the slider switch from down to up in one motion it sets the two limits in the same position.**

- ④ Set the slide switch to the higher position. Move the viewing surface to the desired upper limit by pressing and holding the UP button on the wall switch.
- ⑤ Return the slide switch to the center position to return to normal operation.
- ⑥ To set the viewing surface to an alternate format position, move the viewing surface to the desired position and press the STOP button. Press and hold the STOP button for at least three seconds to record the position.

**Please Note: Pressing and releasing the UP button on the switch will move the screen to its upper limit. Pressing and releasing the DOWN button will move the screen to its lower limit.**

While the motor is in motion, pressing the STOP button for less than two seconds will stop the viewing surface at its present position.

Once the motor is stopped, pressing the STOP button will move the viewing surface to its alternate format position.

Pressing and holding the STOP button, when the motor is at rest or in motion, for at least three seconds will record a new alternate format position.

Back View

**Please Note: 5V DC must be connected to be able to set limits using the wall switch.**

POSITION	FUNCTION
DOWN	Set LOWER limit
UP	Set UPPER limit
CENTER	Normal Operation

### Case Dimensions

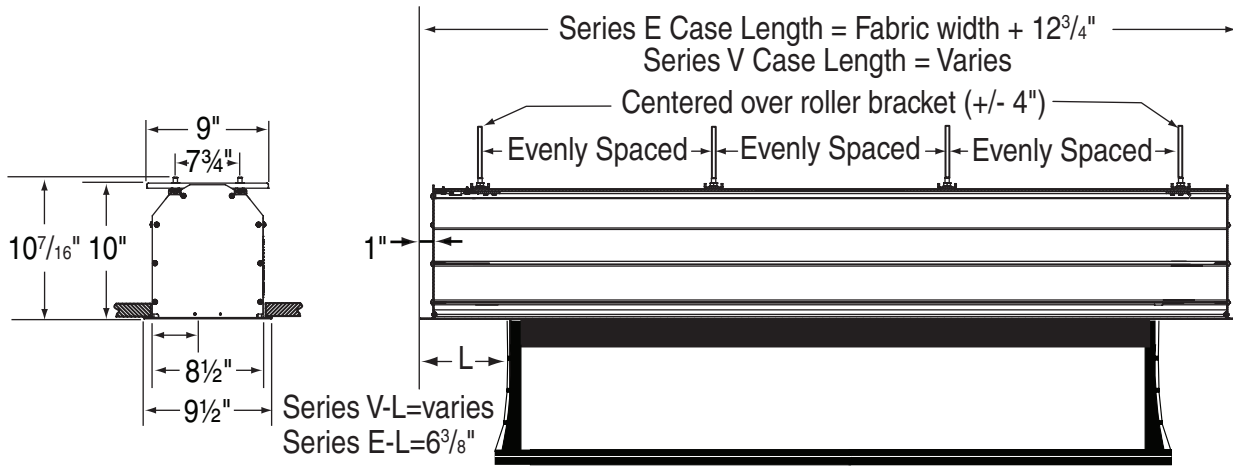

### Ceiling Mounting Bracket Locations and Configurations

**Typical Installation:** Two outermost ceiling mounting brackets (on the ends) must be centered over the interior roller brackets (+/- 4"). Two intermediate brackets should be spaced evenly from the outermost ceiling mounting brackets.

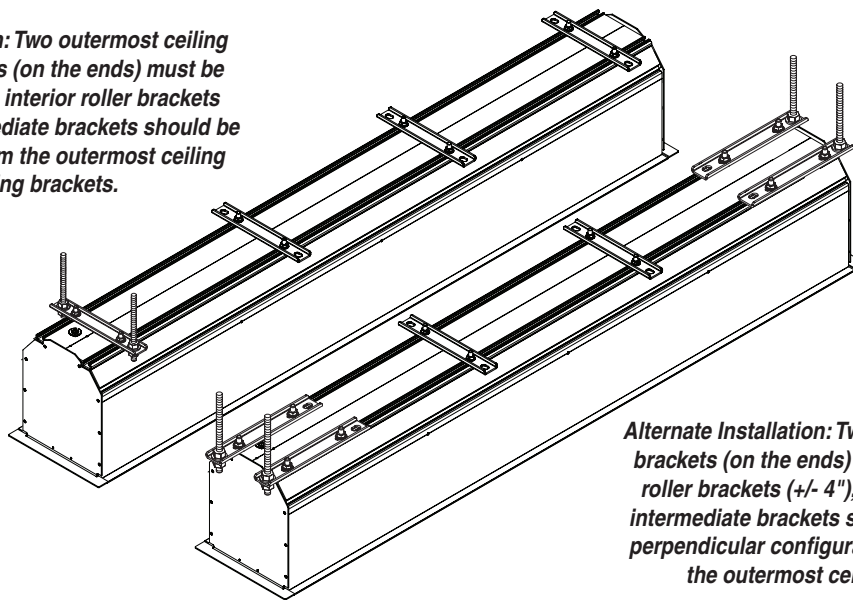

**Alternate Installation:** Two outermost ceiling mounting brackets (on the ends) are centered over the interior roller brackets (+/- 4"), parallel to the case. The two intermediate brackets should be placed in the typical perpendicular configuration, and spaced evenly from the outermost ceiling mounting brackets.

### Wiring Diagrams—110-120V Motor

Please Note: Do not wire motors in parallel.

#### Single Station Control

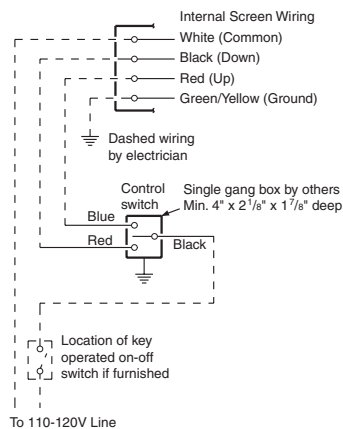

#### Multiple Station Control

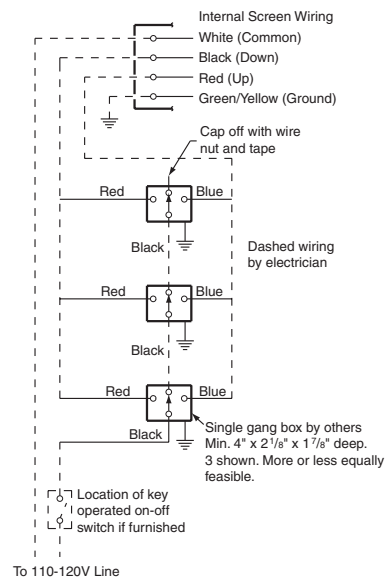

### Wiring Diagrams—110-120V Motor with Built-in Low Voltage Controller

#### Single Low Voltage Control

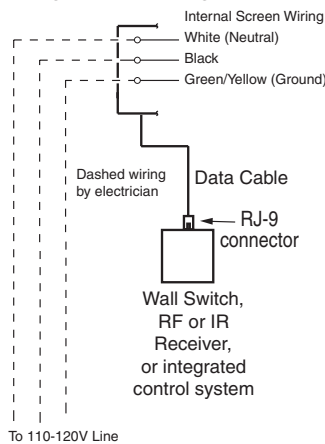

#### Multiple Low Voltage Controls

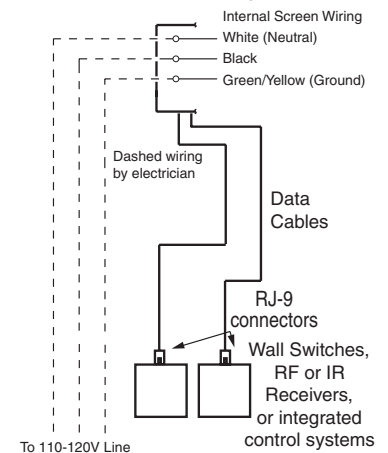

\*These wiring diagrams are for Access XL screens with motor on audience left (standard), and fabric unrolling from the back of the roller (standard).

**ILT Switch-to-Motor—Dry Contacts or Data Cable connection**

**Please Note: 5V DC must be connected to be able to set limits using the wall switch.**

Back of wall switch.

**Please Note: Although both Dry Contact and Data Cable connections are shown, you should only use one connection type per motor.**

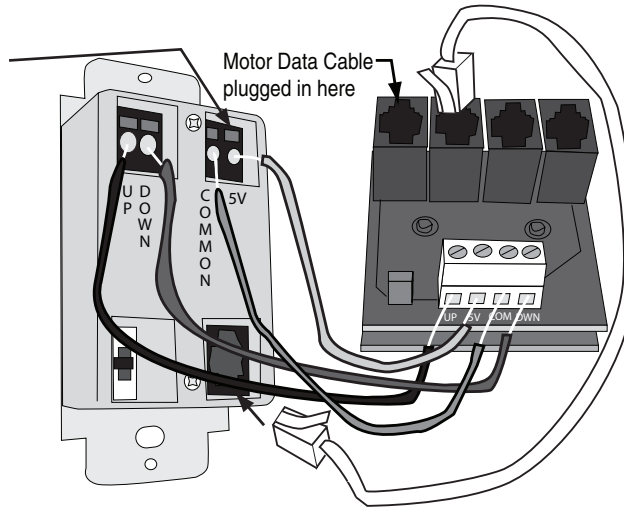

**Please Note: This Splitter/Jack is located inside the junction box of your Access XL screen.**

**Data Cables to switches or to additional motors can be plugged into any of the three open jacks. If this is a "Case First, Screen Later" installation, plug the motor cable into the jack indicated in the drawing.**

**Two-Way Serial Communication (RS232) with MC1**

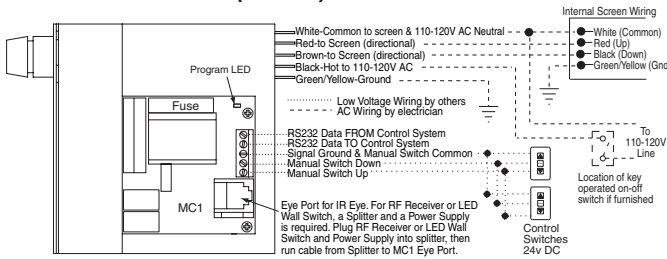

**Low Voltage and Wireless Control (LVC-III)**

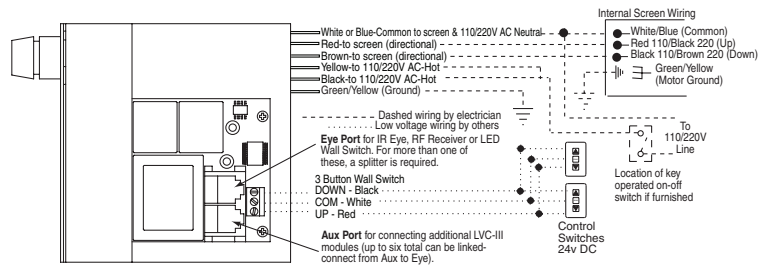

See separate Serial Communication-RS232 Instruction sheet for enabling RS232 with the MC1.

**Built-In VIC-12/VIC-6\***

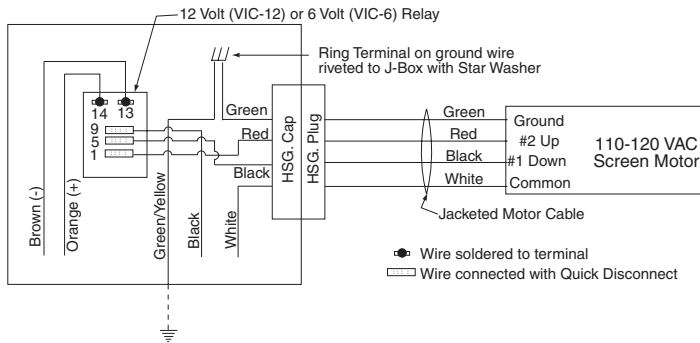

**Built-In VIC-115\***

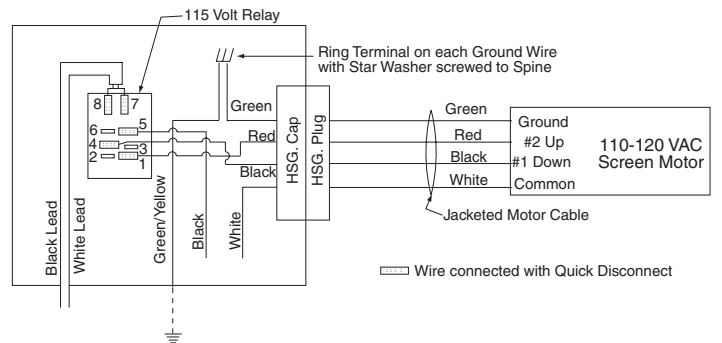

\*These wiring diagrams are for Access XL screens with motor on audience left (standard), and fabric unrolling from the back of the roller (standard).

**Mounting Bracket Dimensions**

