



## VENTING INSTRUCTIONS FOR DIRECT VENT FIREPLACES

---

### APPLICATION

These instructions apply to the Simpson Dura-Vent Direct Vent System, Model DV-GS. This venting system, in combination with the gas appliance, has been tested and listed as a decorative gas appliance system, or as a direct vent heater system by a major testing agency such as UL, AGA, CGA, Omni or Warnock Hersey. Check the manufacturer's rating plate and instruction manual to confirm that the Simpson Dura-Vent direct vent system is approved for use on the brand name appliance you have selected.

### IMPORTANT

Read all instructions carefully before starting the installation. Failure to follow these instructions may create a fire or other safety hazard, and will void the warranty. Be sure to check the appliance manufacturer's installation instructions for specific venting and clearance to combustibles requirements, which may vary from one appliance to another. **Do not extend the venting system vertically or horizontally in excess of the distance prescribed in the appliance manufacturer's installation instructions.**

### INSTALLATION PRECAUTIONS

The Simpson Dura-Vent Direct Vent System is an engineered product that has been designed and tested for use with an approved list of direct vent fireplaces. The Simpson Dura-Vent warranty will be voided, and serious fire, health, or other safety hazards may result from any of the following actions:

- Installation of any damaged Direct Vent component.
- Unauthorized modification of the Direct Vent System
- Installation of any component part not manufactured or approved by Simpson Dura-Vent.
- Installation other than as instructed by Simpson Dura-Vent and the appliance manufacturer.

Consult your local building codes before beginning the installation.

### **WARNING**

• **Always maintain required clearances (air spaces) to nearby combustibles to prevent a fire hazard. Do not fill air spaces with insulation.**

Be sure to check the appliance manufacturers's installation instructions for minimum clearance requirements between the outer walls of the vent pipe and nearby combustible surfaces. Be sure to check the vent termination clearance requirements from decks, windows, soffits, gas regulators, air supply inlets, and public walkways, as specified in these installation instructions and local building codes.

• **The fireplace and vent system must be vented directly to the outside of the building.** Each direct vent fireplace must use it's own separate vent system. Common vent systems are prohibited.

### **SAFETY PRECAUTIONS FOR THE INSTALLER**

- Wear gloves and safety glasses for protection.
- Exercise extreme caution when using ladders or on roof tops.
- Be aware of electrical wiring locations in walls and ceilings.

### **PARTSLIST**

The Simpson Dura-Vent Direct Vent System offers a complete line of component parts for installation of both horizontal and vertical installations. The galvanized pipe and fittings are used for concealed locations such as attics, or spaces where corrosion is a factor, such as above the roofline. Snorkel terminations are available for applications which may require vertical rise on the building exterior.

## PARTSLIST

<u>Number</u>		<u>Description</u>
<u>7" x 4"</u>	<u>8" x 5"</u>	
11008	1208	6" Pipe Length
11007	1207	9" Pipe Length
11006	1206	12" Pipe Length
11004	1204	24" Pipe Length
11003	1203	36" Pipe Length
11002	1202	48" Pipe Length
11017	1217	17" to 24" Pipe, Adjustable
11045	1245	45° Elbow
11090	1290	90° Elbow
11043	1243	Flashing, 0/12 to 6/12 Roof Pitch
11044	1243S	Flashing, 7/12 to 12/12 Roof Pitch
11053	1253	Storm Collar
11063	1263	Ceiling Firestop
11042	1242	Wall Firestop
11088	1288	Wall Strap
11081	1281	Snorkel Termination (36")
11082	1282	Snorkel Termination (14")
11084	1284	Horiz. Square Termination
11030	1230	Horiz. Round Termination
11080	1280	Vertical Termination
11091	1291	Vert. Termination, High Wind
11050	1250	Vinyl Siding Standoff

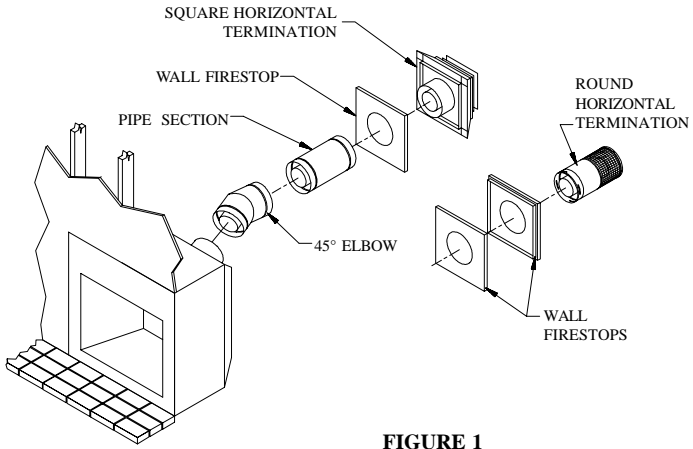

**FIGURE 1**

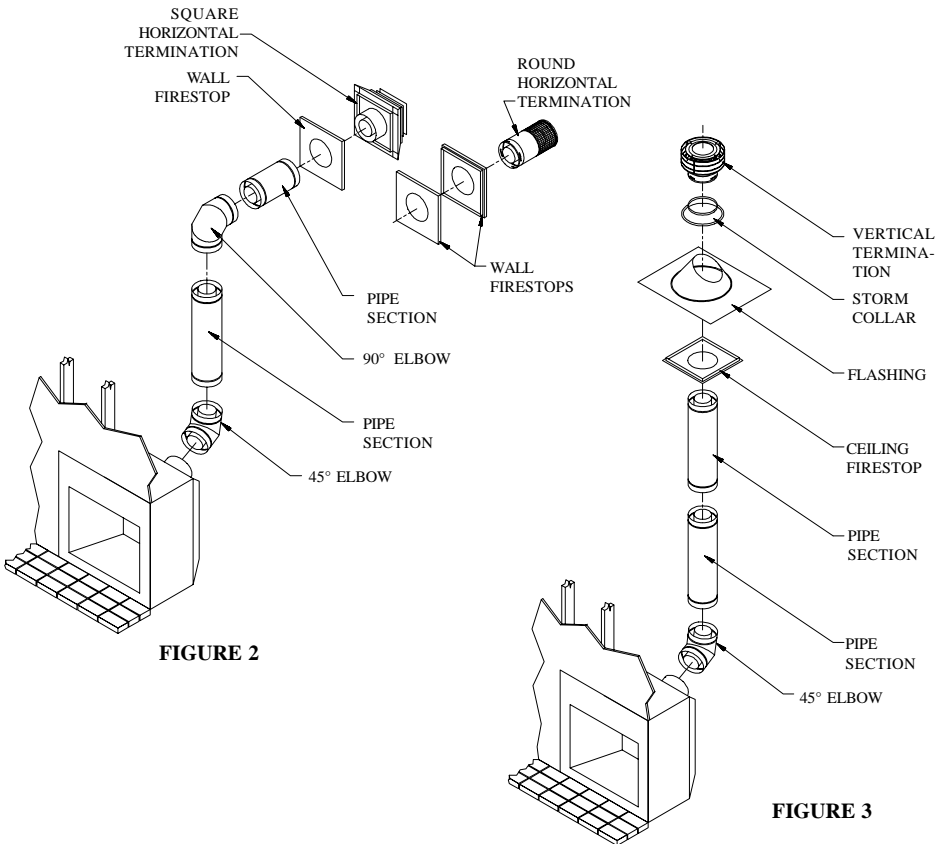

**FIGURE 2**

**FIGURE 3**

## **PLANNING YOUR INSTALLATION**

There are two basic types of Direct Vent System installations. Check the appliance manufacturer's installation instructions to confirm what types are permitted, and also check for any venting restrictions such as maximum horizontal run, and maximum vertical rise. The two types of installations are:

- Horizontal Termination (Fig 1 and Fig 2)
- Vertical Termination (Fig 3)

When planning your installation, it will be necessary to select the proper length of vent pipe for your particular requirements. For horizontal installations, check the appliance manufacturer's installation instructions to determine the minimum clearance from the rear of the appliance to the wall. It is also important to note the wall thickness. Select the amount of vertical rise desired for "vertical-to-horizontal" type installations. To determine the length of vent pipe required for vertical installations, measure the distance from the appliance flue outlet to the ceiling, the ceiling thickness, the vertical rise in an attic or second story, and allow for sufficient vent height above the roofline. For two-story applications, firestops are required at each floor level. If an offset is needed in the attic, additional pipe and elbows will be required.

### **HORIZONTAL INSTALLATION**

**Step 1.** Set the fireplace in its desired location. Check to determine if wall studs or roof rafters are in the way when the venting system is attached. If this is the case, you may want to adjust the location of the appliance.

**Step 2.** Direct Vent pipe and fittings are designed with special twist-lock connections. To connect the venting system to the appliance flue outlet, a twist-lock appliance adaptor is required. With some brands of appliances, the Simpson Dura-Vent adaptor will be built into the appliance at the factory. With other brands, it will be supplied by the appliance manufacturer, for installation in the field. Assemble the desired combination of pipe and elbows to the appliance adaptor with pipe seams oriented towards the wall or floor, as much out of view as possible. If the appliance adaptor is not built into the appliance at the factory, it may be preferable to assemble the pipe and elbows to the adaptor prior to mounting the adaptor onto the fireplace. In this manner, the pipe and 45° elbow assembly may be properly

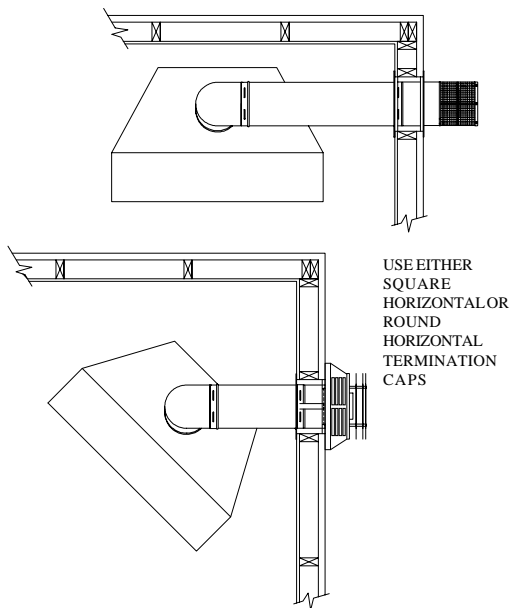
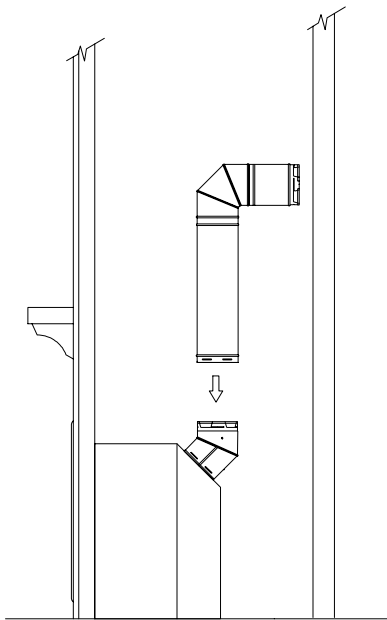

**Fig 4**

twist-locked and rotated to face the wall termination, with final positioning of the vent pipe assembly determined by the mounting orientation of the appliance adaptor onto the fireplace. Figure 4 shows some of the possible vent pathway options. Consult the appliance manufacturer for any restrictions.

**Notes:**

(1) Twist-lock procedure: Four indentations, located on the female ends of pipes and fittings, are designed to slide straight onto the male ends of adjacent pipes and fittings, by orienting the four pipe indentations so they match and slide into the four entry slots on the male ends. (Fig 5). Push the pipe sections completely together, then twist-lock one section clockwise approximately one-quarter turn, until the two sections are fully locked.

(2) Horizontal runs of vent must be supported every three feet. Wall Straps are

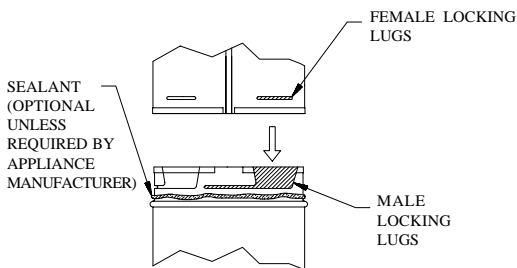

**Fig 5**

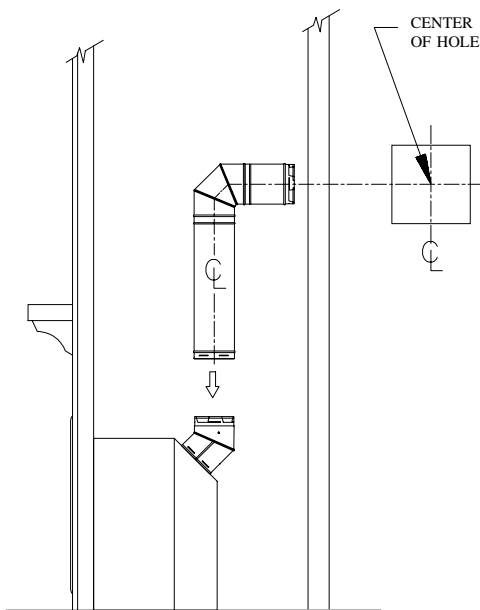

**Fig 6**

the centerline of the horizontal pipe, as shown in Figure 6. Cut and frame the square hole in the exterior wall where the vent will be terminated. If the wall being penetrated is constructed of noncombustible material, i.e. masonry block or concrete, a hole with zero clearance to the pipe is acceptable.

**Notes:**

(1) The horizontal run of vent must be level, or have a 1/4-inch rise for every 1 foot of run towards the termination. Never allow the vent to run downward. This could cause high temperatures and may present the possibility of a fire.

(2) The location of the horizontal vent termination on an exterior wall must meet all local and national building codes, and must not be easily blocked or obstructed. Termination clearances are as follows:

- (a) Clearance above the ground, veranda, porch, deck or balcony - 12 inches minimum.
- (b) Clearance to a window or door that may be opened - 9 inches minimum.
- (c) Vertical clearance to a ventilated soffit located above the termination with a horizontal distance of 2 feet from the centerline of the termination - 18 inches minimum.
- (d) Clearance to an unventilated soffit - 12 inches minimum.

available for this purpose.

(3) Sealant is optional, unless specified by the appliance manufacturer. Should you elect to use sealant, it is only necessary on the outer tube of the GS Pipe. Run a 1/8-inch wide bead of sealant around the male end of the outer sleeve, as shown in Figure 5, and twist-lock the pipes or fittings together.

**Step 3.** With the adaptor and pipe attached to the fireplace, slide the fireplace into it's correct location, and mark the wall for a square hole of the appropriate size. Use a 10"x10" square hole for 7" x 4" pipe and use an 11"x11" square hole for 8" x 5" pipe. The center of the square hole should line up with

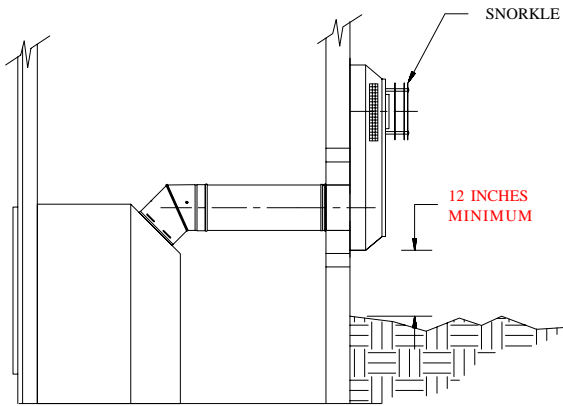

**Fig 7**

(e) Clearance to an outside corner -as tested.

(f) Clearance to an inside corner -as tested.

(g) Not to be installed above a meter/regulator assembly within 3 feet horizontally from the centerline of the regulator.

(h) Clearance to a service regulator vent outlet -6 feet minimum.

(i) Clearance to non-mechanical air supply inlet to a building or the combustion air inlet to any other appliance -12 inches minimum.

(j) Clearance to a mechanical air supply inlet -6 feet minimum.

(k) Clearance above a paved sidewalk or paved driveway located on public property -refer to local code.

(l) Clearance under a veranda, porch, deck or balcony -12 inches minimum.

For installations requiring a vertical rise on the exterior

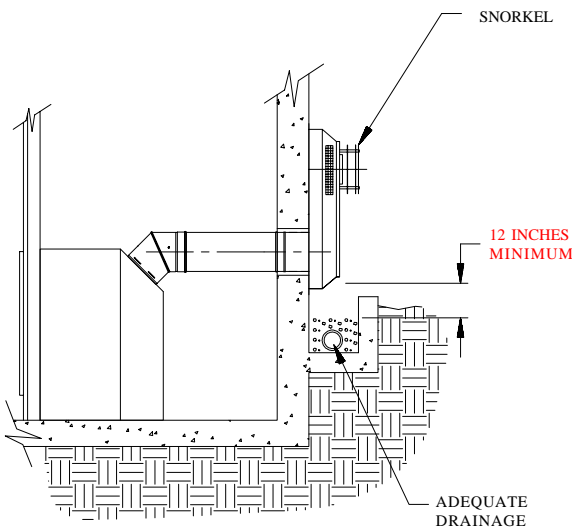

**Fig 8**

of the building, 14-inch and 36-inch tall Snorkel Terminations, as shown in Figure 7 are available. Follow the same installation procedures as used for standard Square Horizontal Terminations. If the Snorkel Termination must be installed below grade, (i. e. basement application), proper drainage must be provided to prevent water from entering the Snorkel Termination. Refer to Figure 8. Do not attempt to enclose the Snorkel within the wall, or any other type of enclosure.

**Step 4.** For a Square Horizontal Vent Termination, place the vent cap in the center of the square hole and attach to the exterior wall with the four wood screws provided. Before attaching the Vent Termination to the exterior wall, run a bead of non-hardening sealant around it's outside edges, so as to make a seal between it and the wall. If you are using a Round Horizontal Vent Termination, place an exterior Wall Firestop over the square hole. Run a bead of non-hardening sealant around the edges of the Wall Firestop, and attach the Wall Firestop to the wall with the four wood screws provided. The arrow on the vent cap should be pointing up. Insure that proper clearances to combustibile materials are maintained. (Fig 9)

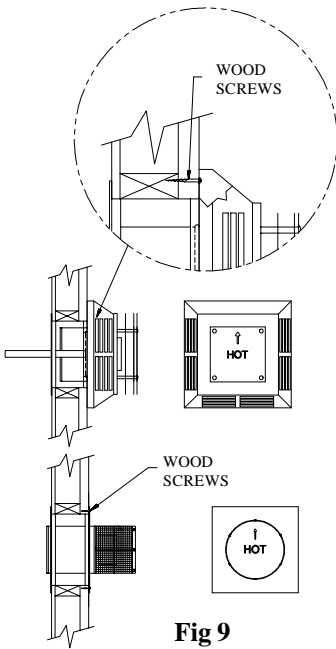

**Fig 9**

**Notes:**

(1) The four wood screws provided

should be replaced with appropriate fasteners for stucco, brick, concrete, or other types of sidings.

(2) For buildings with vinyl siding, a Vinyl Siding Standoff, should be installed between the vent cap and the wall. (Fig 10) Attach the Vinyl Siding Standoff to the Horizontal Vent Termination. The Vinyl Siding Standoff prevents excessive heat from possibly melting the vinyl siding material. Note that the Square Horizontal Vent Termination bolts onto the flat portion of the Vinyl Siding Standoff,

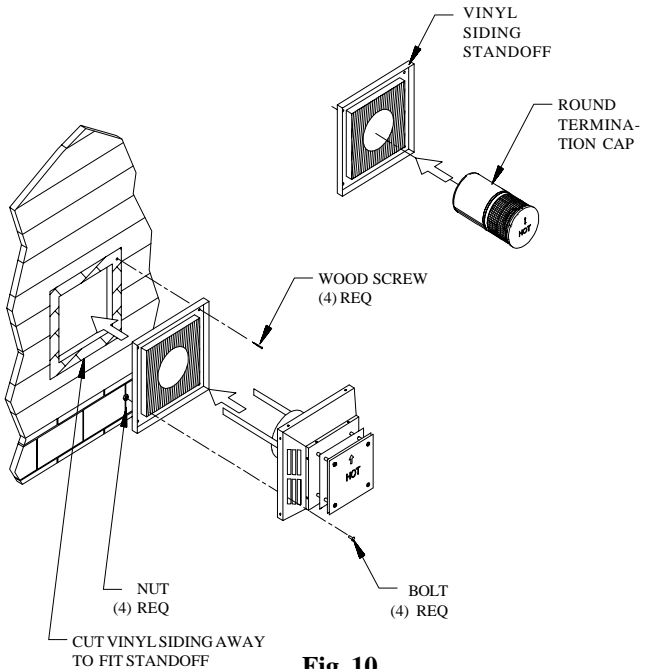

**Fig 10**

**Fig 11**

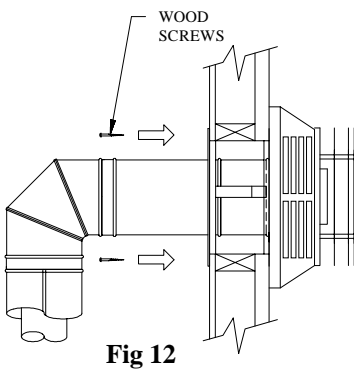
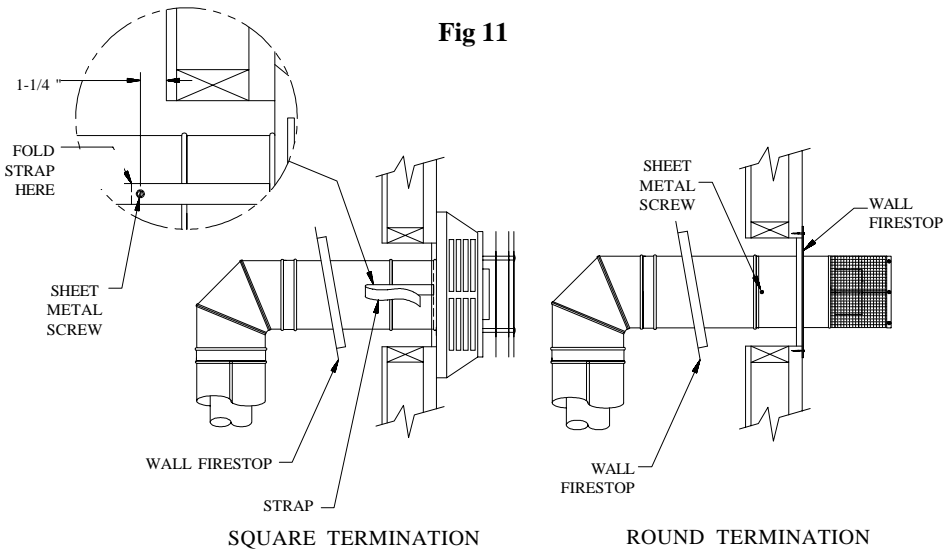

**Fig 12**

(shaded area shown in [Figure 10](#)), so that an air space will exist between the wall and the Vent Termination. The Round Horizontal Vent Termination does not need an exterior Wall Firestop when using a Vinyl Siding Stand-off. Simply slide the round termination through the Vinyl Siding Standoff in order to connect to the vent piping. Be sure that all of the vent cap mesh is to the exterior of the wall.

**Step 5.** Before connecting the horizontal run of vent pipe to the vent termination, slide the Wall Firestop over the vent pipe on the interior side of the wall.

**Step 6.** Slide the appliance and vent assembly towards the wall, carefully inserting the vent pipe into the vent cap assembly. It is important that the vent pipe extend into the vent cap sufficient distance so as to result in a minimum pipe overlap of 1-1/4 inches. Secure the connection between the vent pipe and the vent cap. For square caps, attach the two sheet metal strips extending from the vent cap assembly into the outer wall of the vent pipe. Use the two sheet metal screws provided to connect the sheet metal strips to the pipe section. For round caps, use three sheet metal screws and attach cap to pipe section. (Fig 11)

**Step 7.** Slide the Wall Firestop up to the wall surface and attach with screws provided. (Fig 12)

## VERTICAL TERMINATION

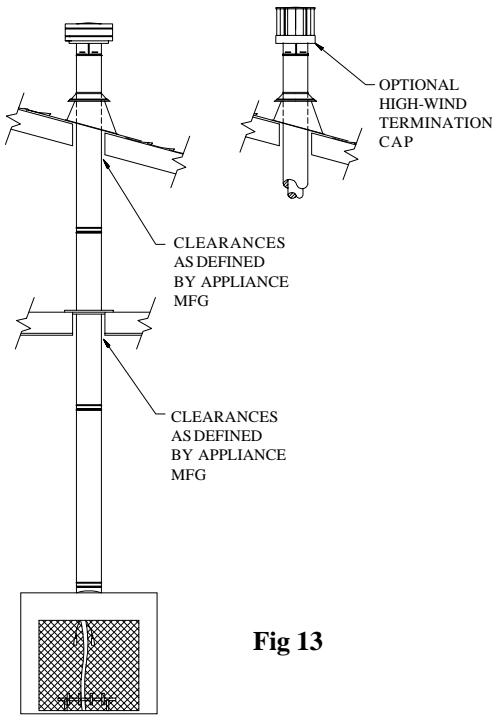

**Fig 13**

**Step 1.** Check the appliance manufacturer's installation instructions for required clearances (air spaces) to combustibles when passing through ceilings, walls, roofs, enclosures, attic rafters, or other nearby combustible surfaces. Do not pack air spaces with insulation. Check the appliance manufacturer's instructions for maximum vertical rise of the venting system, and any maximum horizontal offset limitations. (Fig 13)

**Step 2.** Set the fireplace in its desired location. Drop a plumb bob from the ceiling to the position of the appliance flue exit, and mark the location where the vent will

penetrate the ceiling. Drill a small hole at this point. Next, drop a plumb bob from the roof to the hole previously drilled in the ceiling, and mark the spot where the vent will penetrate the roof. Determine if ceiling joists, roof rafters, or other framing will obstruct the venting system. You may wish to relocate the appliance, or to offset, to avoid cutting load-bearing members.

**Step 3.** To install the Ceiling Firestop in a flat ceiling,

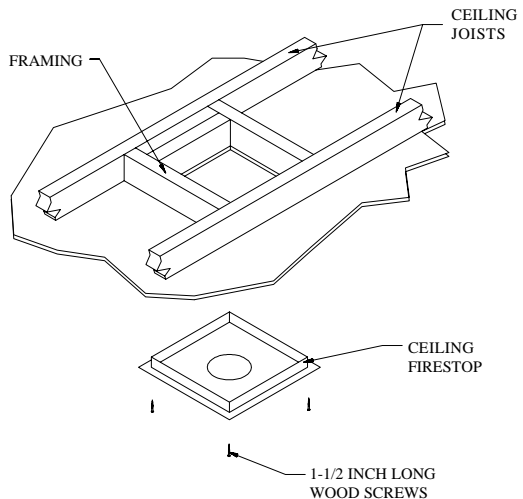

**Fig 14**

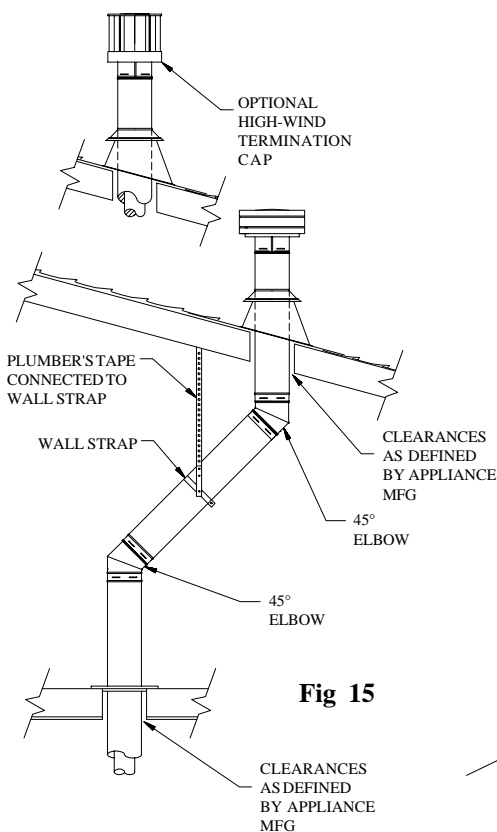

**Fig 15**

**Step 6.** Cut a hole in the roof centered on the small drill hole placed in the roof in Step 2. The hole should be of sufficient size to meet the minimum requirements for clearance to combustibles, as specified by the appliance manufacturer. Continue to assemble lengths of Pipe and Elbows necessary to reach from the Ceiling Firestop up through the roof line.

cut a square hole in the ceiling, (10"x10" square for 7" x 4" pipe, 11"x11" square for 8" x 5" pipe) centered on the hole drilled in Step 2. Frame the hole as shown in Fig 14.

**Step 4.** If the Twist-lock adaptor has not been installed on the fireplace by the manufacturer, install it now in accordance with the fireplace instruction manual.

**Step 5.** Assemble the desired lengths of Galvanized Pipe and Elbows necessary to reach from the Appliance Adaptor up through the Ceiling Firestop. Insure that all Pipe and Elbow connections are in their fully twist-locked position.

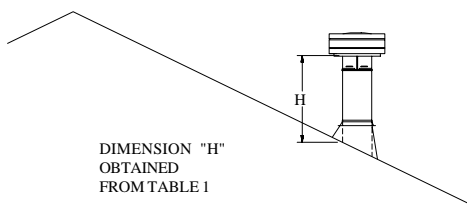

**Fig 16**

TABLE 1		
ROOF PITCH	MINIMUM HEIGHT	
	FEET	METERS
FLAT TO 7/12	1	0.3
OVER 7/12 TO 8/12	1.5	0.46
OVER 8/12 TO 9/12	2	0.61
OVER 9/12 TO 10/12	2.5	0.76
OVER 10/12 TO 11/12	3.25	0.99
OVER 11/12 TO 12/12	4	1.22
OVER 12/12 TO 14/12	5	1.52
OVER 14/12 TO 16/12	6	1.83
OVER 16/12 TO 18/12	7	2.13
OVER 18/12 TO 20/12	7.5	2.29
OVER 20/12 TO 21/12	8	2.44

**Notes:**

(1) If an offset is necessary in the attic to avoid obstructions, it is important to support the vent pipe every 3 feet, to avoid excessive stress on the Elbows, and possible separation. Wall Straps are available for this purpose. (Fig 15)

(2) Whenever possible, use 45° Elbows, instead of 90° Elbows. The 45° Elbow offers less restriction to the flow of flue gases and intake air.

**Step 7.** Slip the flashing over the Pipe Section(s) protruding through the roof. Use a non-hardening sealant between the Flashing and the roof to prevent water leakage. Secure the base of the Flashing to the roof with roofing nails. Insure the roofing material overlaps the top edge of the Flashing as shown in Fig 17. Verify that you have at least the minimum clearance to combustibles at the roofline.

**Step 8.** Continue to add Pipe Sections until the height of the Vent Cap meets the minimum building code requirements described in Fig 16. Note that for steep roof pitches, the vent height must be increased. In high wind conditions, nearby trees, adjoining rooflines, steep pitched roofs, and other similar factors can result in poor draft, or down-drafting. In these cases, increasing the vent height may

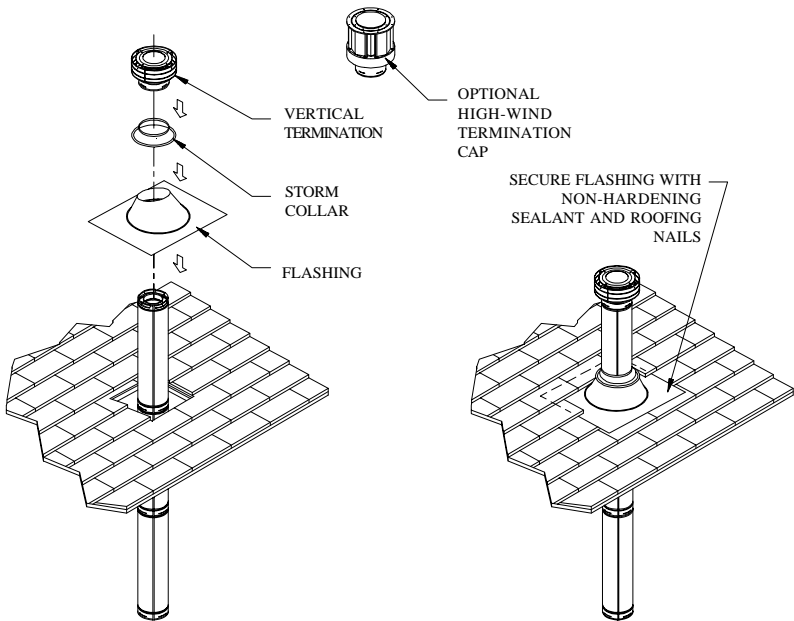

**Fig 17**

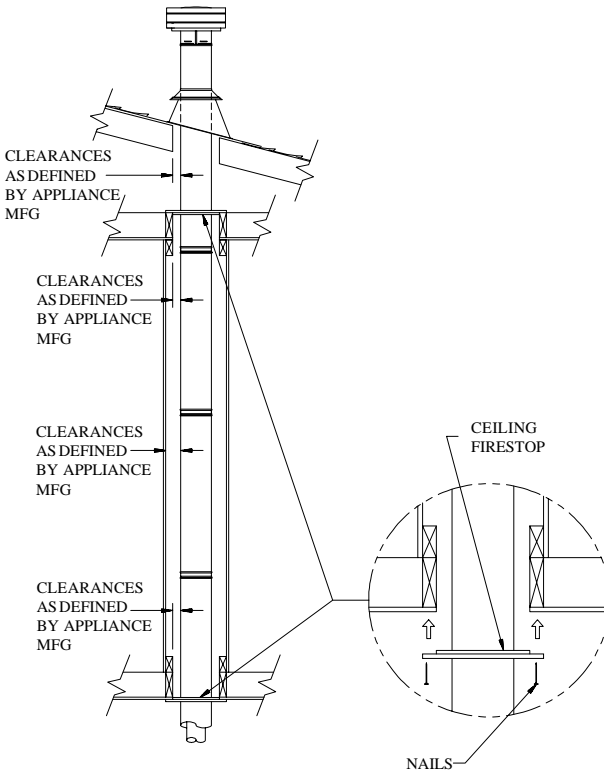

**Fig 18**

The enclosure may be framed and sheetrocked with standard construction materials, however consult the appliance manufacturer's installation instructions for the minimum allowable clearance between the outside of the vent pipe, and the combustible surfaces of the enclosure. Do not fill any of the required air spaces with insulation.

## **GENERAL MAINTENANCE**

Conduct an inspection of the venting system semi-annually. Recommended areas to inspect are as follows:

solve this problem.

**Step 9.** Slip the Storm Collar over the Pipe, and push it down to the top of the Flashing, as shown in Fig 17. Use the non-hardening sealant above and below the joint between the Storm Collar and the Pipe.

**Step 10.** Twist lock the Vent Cap.

### **Notes:**

(1) For multi-story vertical installations, a Ceiling Firestop is required at any subsequent floors. (Fig 18) The opening should be cut and framed in the same manner as the opening in Step 3. (See Fig 14) (2) Any occupied areas above the first floor, including closets and storage spaces, which the vertical vent passes through, must be enclosed.

1. Check areas of the Venting System which are exposed to the elements for corrosion. These will appear as rust spots or streaks, and in extreme cases, holes. These components should immediately be replaced.

2. Remove the Cap, and shine a flashlight down the vent. Remove any bird nests, or other foreign material.

3. Check for evidences of excessive condensate, such as water droplets forming in the inner liner, and subsequently dripping out at joints. Continuous condensate can cause corrosion of caps, pipe, and fittings. It may be caused by having excessive lateral runs, too many elbows, and exterior portions of the system being exposed to cold weather.

4. Inspect joints, to verify that no Pipe Sections or Fittings have been disturbed, and consequently loosened. Also check mechanical supports such as Wall Straps, or plumbers' tape for rigidity.

### **LABELS**

All components are labelled with the appropriate identification information, and the listing data.

Other products made by Simpson Dura-Vent:

**Dura/Plus** Chimney

**Dura-Vent** Gas Vent (B-Vent)

**Dura-Black** Single Wall Stovepipe

**Dura/Liner** Masonry Reliner

**DVL** Close Clearance Connector Pipe

**Dura/Connect** Single-Wall Connector for B-Vent

**DuraFlex** Masonry Reliner for Gas Appliances

**Designer Series** Accessories



**SIMPSON  
DURA-VENT, INC**  
PO Box 1510  
Vacaville, CA  
95688-1510  
  
Vicksburg, MS

(800)-835-4429  
(707)-446-4740 (FAX)

May 1996  
L951