

MSM

Microphone Shock Mount

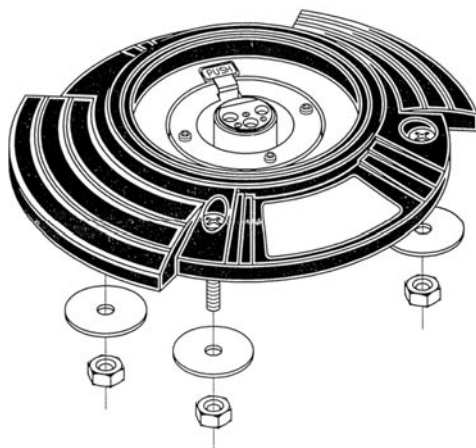

Description

The MSM is a plug-in shock mount microphone base for desktop and counter use. Its contemporary design is a complementing fixture for boardrooms, conference rooms, pulpits, podiums, or newsrooms. It is ideal for use with gooseneck microphones and other quick-mount types using XLR (male) type connectors. The black-finish housing is made of lightweight ABS material. It supports the XLR (female) type connector and the thick shock-absorbing rubber cushion.

The MSM is easily screwed on a flat surface with a maximum thickness of 3/4" providing maximum stability and excellent noise insulation, and vibration handling for live miking situations.

The MSM allows convenient wiring with its flush-mounted XLR (female) connector. The signal appears across pin nos. 2 and 3 while the ground connection is in pin no. 1.

Features

- Contemporary design and excellent engineering for desktop and counter use
- Easy setup and quick plug-in design
- Superior mechanical noise and vibration handling
- Ideal fixture for boardrooms, conference rooms, pulpits, podiums, newsrooms

Installation

1. Surface Preparation:

- a. Make sure that the surface on which the MSM will be installed is flat and stable.
- b. Using the dimensions shown below, drill the holes for the mounting screws.
 - The thickness of the table/platform must not exceed 3/4". Counter bore hole on bottom of table for thicker tops.

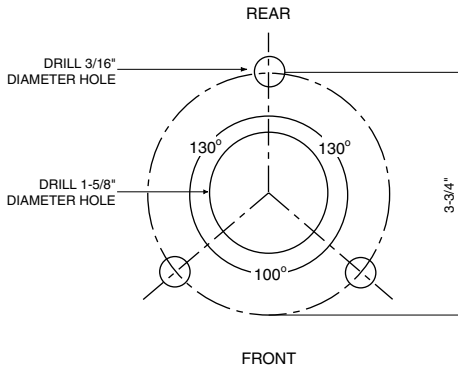

2. XLR (Female) Connector Diagram:

- Solder 2-conductor with shield microphone cable to connector. Figure shows typical connections for balanced microphones. Check instructions for microphone actually being used to confirm proper connections.

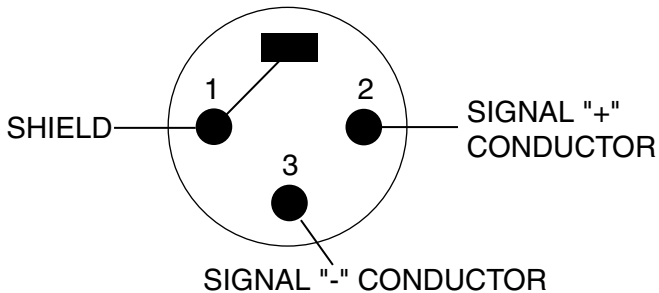

3. Mounting:

- a. Remove the nuts and the washers from the shock mount base.
- b. Mount the base on the intended surface.
- c. Tighten the screws enough to ensure stability. *Over tightening will suppress shock absorbing capability of the rubber cushion.*

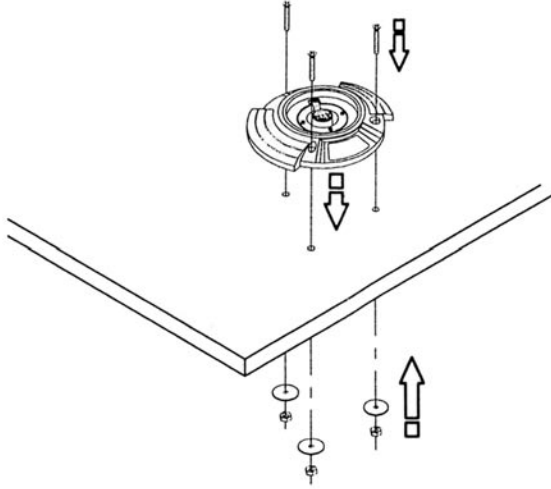

4. Connecting a Microphone (shown with GDU150):

- The outside diameter of the microphone connector's housing should not exceed $3/4$ ", with its length $3/4$ " or longer. This is to ensure its complete and lock-tight connection with the flush-mounted XLR (female) connector of the shock mount base.

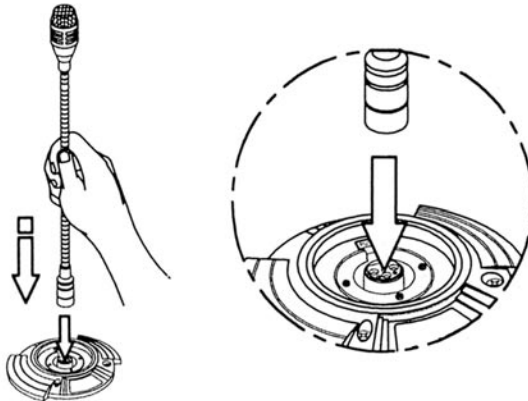

5. Removing a Microphone:

- Pull out the microphone while pressing the release tab of the XLR (female) connector of the shock mount base.

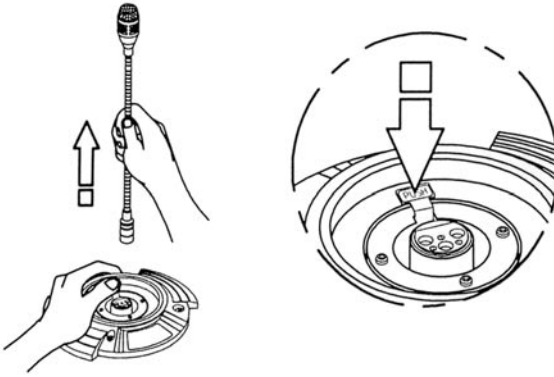

BOGEN[®]
COMMUNICATIONS, INC.

50 Spring Street, Ramsey, NJ 07446, U.S.A.
Tel: 201-934-8500; Fax: 201-934-9832, www.bogen.com