

BOGEN[®]

COMMUNICATIONS, INC.

PUBLIC ADDRESS AMPLIFIERS

MODEL CT100C

The Bogen CT100C is a uniquely versatile amplifier designed for professional-quality sound systems that previously required custom assemblies. The unit is rated at 100 watts output, is comprised of integrated circuits, silicon transistors and diodes, and is UL and CSA listed. It incorporates the latest state-of-the-art active 2/3-octave equalization circuitry.

Six low-impedance, transformer-isolated, balanced microphone inputs, each with individual volume controls, are convertible to high-impedance inputs by rearranging jumpers on the printed circuit board. A phantom power supply for use with condenser microphones is included. Professional three-pin female microphone connectors are provided on the rear panel.

Two auxiliary channels, with an AUX 1/AUX 2 fader control, can be used for inputs from a tuner, tape/cassette player, or an optional TG-4C Multiple Tone Generator.

Built-in microphone precedence, remote volume control, and 500/600-ohm line input and output, with accessories, tape and tape/booster outputs, and amplifier bridging are among the many capabilities of the unit.

Ten slide controls, with detented flat positions, allow the selected frequency equalizer filter circuit to meet installation requirements. Feedback can be virtually eliminated, while intelligibility is greatly improved and usable power increased.

A recessed screwdriver-adjustable front panel control for an electronic compressor circuit is also provided. This circuit compensates for poor microphone technique or the differing styles of a variety of announcers, and it eliminates "blasting" in background music applications.

Screw terminals on the rear panel allow connections to standard speaker impedance taps, as well as connections for 25-volt and 70-volt balanced lines.

The amplifier operates from a 120 volt, 60Hz source. A three-prong line cord provides automatic grounding when connected to a three-wire grounded power outlet. The power line is protected by a circuit breaker, and the output transistors by a thermal overload device, which shuts off the unit when the temperature of the heat sink rises excessively.

INSTALLATION

UNPACKING

The amplifier was carefully checked before leaving the factory. Inspect the shipping container and unit carefully for indication of improper handling. If the unit has been damaged, make an immediate claim to the distributor from whom it was purchased. If the amplifier was shipped directly to you, notify the transportation company without delay and place your claim.

POWER AND GROUNDING

The AC line cord has a three-prong plug which should be plugged into a three-wire grounded 120-volt, 60Hz outlet. It is important to ground the amplifier. If a three-wire outlet is not available, use an adapter and connect the grounding pigtail to the screw securing the wall plate to the outlet box; however, if the outlet box is not grounded, connect a wire from the GND terminal of the amplifier output terminal strip to a suitable earth ground.

CAUTION

The following installation instructions are for use by qualified service personnel only. To avoid an electric shock, do not perform any functions requiring the removal of the cover of the amplifier unless you are qualified to do so.

INPUT CONNECTIONS

LOW-IMPEDANCE BALANCED MICROPHONES: The amplifier is designed for direct connection of low-impedance balanced microphones to the MIC input receptacles of the amplifier. The microphone lead should be a two-conductor shielded cable terminated in a three pin male connector, as shown in Figure 1.

CONDENSER MICROPHONES: Connect in the same manner as for low-impedance balanced microphones.

HIGH-IMPEDANCE MICROPHONES: The microphone lead should be a single-conductor shielded cable under 35 feet in length and terminated in a three pin male connector, as shown in Figure 1. For information regarding the use of high-impedance microphones, see Note 3 on the schematic diagram.

MICROPHONE PRECEDENCE: A built-in circuit provides microphone precedence for special announcements. A customer-supplied SPST switch with normally-open contacts is required for this function. When the contacts are closed, the auxiliary and other microphone inputs are muted.

AUX1/AUX2 INPUTS: Two auxiliary inputs with a fader control are provided for high-level, high-impedance inputs. These may be used to connect a tuner, tape/cassette player, or the input from an accessory WMT-1A line-matching transformer. (Refer to the Accessories Section.) An input signal of 0.15 volts is required to obtain full output from the amplifier.

TECHNICAL SPECIFICATIONS

Power Output:	100W RMS
Distortion:	Less than 2% at RPO, 50Hz to 15kHz
Frequency Response:	50Hz to 15kHz ± 1 dB
Regulation:	2dB
Line Fusing:	Resettable Circuit Breaker 2.5A
Sensitivity (for full output):	Lo-Z balanced MIC, 0.3mV; Hi-Z MIC, 3mV; AUX 0.15V
Hum & Noise (below rated output):	Lo-Z balanced MIC -55dB; Hi-Z MIC -60dB; AUX -70dB
Inputs (impedance):	6 Lo-Z balanced dynamic or condenser MIC inputs, each convertible to Hi-Z MICs; 2 Hi-Z AUX inputs with fader control; 500/600-ohm line input with optional WMT-1A accessory; remote volume control for MIC 1 - 5 & AUX inputs
Outputs (impedance):	4, 6-8, 16 ohm speaker taps, 25VCT and 70V balanced or unbalanced lines, Tape and Tape/Booster, 500/600-ohm line output with WMT-1A optional accessory
Input/Output Connectors:	MIC, professional 3-pin female audio connectors; Hi-Z standard phono jacks for Tape, Tape/Booster, Bridging, and optional accessory WMT-1A output; provision for optional WMT-1A input; screw terminals for speaker connections
Controls:	6 MIC Volume, AUX 1/AUX 2 fader, MASTER VOLUME, 10 Equalizer Filter Slide Controls, Compressor Control, Power Switch
Equalizer Filters:	10 filters centered at preferred ISO center frequencies of 80, 125, 200, 315, 500, 800, 1250, 2000, 3150, and 5000 Hz. Boost/Cut: ± 12 dB
Compression:	5 ms. attack time, 2 s. decay time, max. compression 30dB
Semi-conductors:	21 silicon transistors, 10 ICs, 10 diodes
Power Source/Consumption:	120V, 60Hz, 2.5A, 300W
Dimensions:	16 $\frac{3}{8}$ " W x 13 $\frac{3}{4}$ " D x 4 $\frac{3}{4}$ " H (41.5 x 34.9 x 12cm)
Shipping Weight:	24 lbs.

All specifications subject to change without notice.

Use single-conductor shielded cable terminated in an RCA phono plug for connecting an auxiliary component. If hum is experienced after making connections, run a ground wire between the chassis of the auxiliary unit and the GND terminal of the amplifier.

BRIDGING: Two CT100C amplifiers can be bridged together to double the number of inputs and outputs. Connect a single-conductor shielded cable, terminated in an RCA phono plug at each end, between the rear panel BRIDGING receptacles of the two amplifiers. This cable should not be more than 20 feet in length. If more than two amplifiers are to be bridged, use a "Y" adapter.

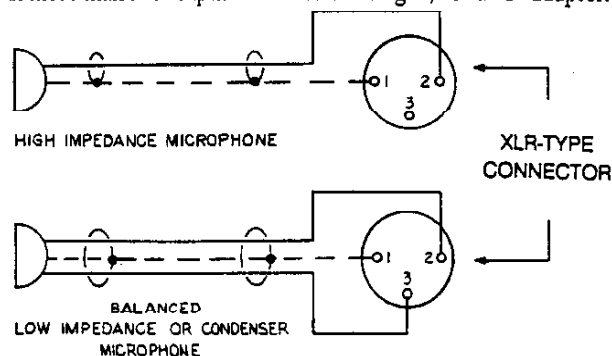

Figure 1 -- Microphone Cable Connections

The BRIDGING GND ONLY terminals on the rear panel terminal strip (TS101) must also be connected to each other. Any input to either amplifier will then be fed through and available at the output of both amplifiers. The amplifiers must each feed separate speaker systems.

NOTE

When two amplifiers are bridged together, any adjustment of the MASTER, COMPRESSION, or Acoustic Equalizer controls in one amplifier will not affect the output of the other amplifier.

OUTPUT CONNECTIONS

SPEAKERS: Output connections are available on the rear panel terminal strip for 4, 8, 16 ohm speakers, 25 volt center-tapped and 70 volt lines. The necessary connections are listed in Table 1. Class 2 wiring may be used.

TAPE OUTPUT: A tape recorder may be driven from the TAPE OUTPUT jack on the amplifier. In this case, the output is not subject to the MASTER volume and equalization settings of the amplifier; it is controlled at the tape recorder. A patch cord, terminated in an RCA phono plug is connected between the TAPE OUTPUT jack on the amplifier and the input of the tape recorder.

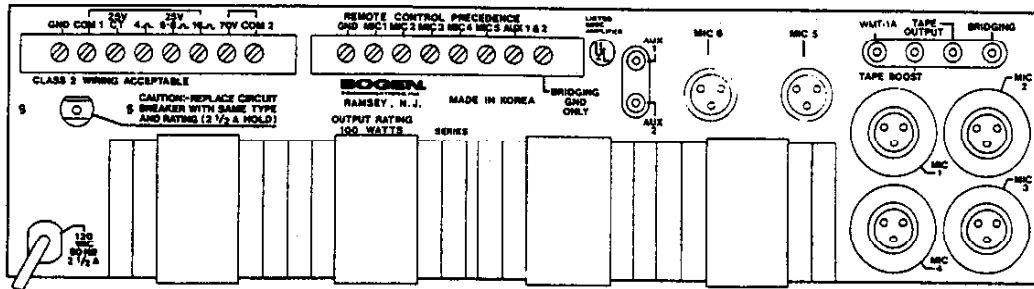

Figure 2 — Rear Panel, CT100C

BOOSTER OUTPUT: The amplifier may be used to drive a booster amplifier. Connect a patch cord with an RCA phono plug from the BOOSTER jack on the rear panel of the amplifier to the high-impedance input of the booster amplifier. The output at this jack is controlled by the amplifier's volume and equalization controls.

WMT-1A OUTPUT: This receptacle is used to accommodate an accessory Bogen Model WMT-1A, which provides connections to a 500/600-ohm telephone line. (Refer to the Accessories Section.)

ACOUSTIC EQUALIZER

The Acoustic Equalizer permits you to "tune" the amplifier to the room in which the sound system is used, so that the amplifier will operate at a substantially higher output before acoustic feedback occurs. Ten slide controls, located on the front panel, boost or attenuate the output at preferred ISO center frequencies of 80, 125, 200, 315, 500, 800, 1250, 2000, 3150, and 5000Hz, to compensate for varying room acoustics.

Microphone placement may also cause feedback or howling at or near some of these frequencies. If so, feedback can be greatly attenuated by setting the slide controls for that particular frequency, as described below.

ACOUSTIC EQUALIZER FILTER ADJUSTMENT

MICROPHONE SOURCE: The following adjustments of the slide filter controls will permit "tuning" the system so that the output level is substantially higher before acoustic feedback ("squeal" or "ringing") occurs.

1. Set the MIC controls and the MASTER control to zero (counterclockwise).
2. Set all the slide controls to the center (flat) position, with speakers connected to the amplifier and microphone(s) in normal operating location(s).
3. Turn the appropriate MIC volume control halfway up, leaving the other MIC volume controls at zero.
4. Advance the MASTER control slowly until feedback is heard.
5. If the feedback sound is high-pitched, one of the five high-frequency filter controls (800 to 5000Hz) will be most effective in its elimination. Likewise, a low-end tone will be best controlled by a low-frequency filter.
6. Individually, move each filter control slowly from the center position to bottom and back to center while listening for a change in the feedback. The control which eliminates feedback with the least movement should then be moved down only as far as is necessary to eliminate the feedback.
7. Having eliminated the first feedback condition, slowly increase the MASTER control until feedback occurs again. Repeat the procedures in Steps 5 and 6.

TABLE 1 — OUTPUT CONNECTIONS

Speaker Line	Terminal Connections*	Other Connections
4W Unbalanced	4Ω and COM 1	Close link between COM 1 and GND
4W Balanced	4Ω and COM 1	Open Link between COM 1 and GND
8W Unbalanced	8Ω and COM 1	Close link between COM 1 and GND
8W Balanced	8Ω and COM 1	Open Link between COM 1 and GND
16W Unbalanced	16Ω and COM 1	Close link between COM 1 and GND
16W Balanced	16Ω and COM 1	Open Link between COM 1 and GND
25V Unbalanced	25V and COM 1	Close link between COM 1 and GND
25V Balanced	25V and COM 1	Open Link between COM 1 and GND
25V Balanced, CT gnd.	25V and COM 1	Connect jumper between 25V CT and GND
		Open link between COM 1 and GND
70V Unbalanced	70V and COM 2	Add jumper between COM 2 and GND
70V Balanced	70V and COM 2	No jumper required

* Also see text under "Output Connections"

8. If the position of the microphone is changed, or if additional microphones are used, some adjustments to these controls may be necessary.
9. Output level, reduced because of attenuating one frequency, may be partly restored by boosting the adjacent frequency filter control toward maximum.

NOTE

If feedback is not a problem, the controls should be used to improve the voice quality and intelligibility of the paging system. In most cases, the 80Hz control should be placed in the minimum position, while the 2000, 3150, and 5000 Hz controls should be moved toward maximum for improved response. Each system, depending upon the speakers used and the room acoustics, will require some experimentation with the controls for optimum results.

10. Note and record the settings of the individual filter controls and the MASTER control. These settings are generally applicable to all MIC input channels. Rubber washers (supplied) can be placed behind the knobs on the slide controls to avoid accidental movement. To do so, pull these knobs off the shafts, insert the rubber washers, and replace the knobs securely. A tinted cover is shipped with each amplifier and may be installed to prevent tampering with the slide controls. Place the cover just under the top of the amplifier and, using the two (2) screws provided, secure it in position.

COMPRESSOR LIMITER: The COMPRESSion control (which is screwdriver-adjustable through the front panel to prevent tampering) is used to provide relatively uniform output from the amplifier, regardless of variations in the input levels. This is particularly important in speech applications, where a microphone may be used by a number of people with varying voices and microphone techniques. It is also useful for musical programs, particularly when handling background music.

The COMPRESSion control is turned clockwise to reduce the output range for a given variation in input range. Turn the control counterclockwise to increase the output range. To remove compression and restore the normal full range of the amplifier, turn the control fully counterclockwise.

To determine the optimum setting of the COMPRESSion control for speech applications, proceed as indicated below. (For music, the setting will generally be lower than for speech.)

Set the COMPRESSion control fully counterclockwise. Set the MASTER volume control to the highest level likely to be required. Use a level setting that will permit you to pick up clearly spoken inputs in a low voice at a distance of three feet on axis from the microphone. However, do not set the level so high as to produce feedback or howling. Then, speaking in a loud voice directly into the microphone, turn the COMPRESSion control clockwise to the point where the output of the amplifier is reduced to the same level as obtained above. The MASTER volume control can be used to vary the overall volume without upsetting the COMPRESSion adjustments.

OPERATION

POWER: This switch applies power to the amplifier. The POWER indicator lamp will go on to show that power has been applied to the unit.

MIC VOLUME: The individual MIC volume controls are used to adjust the level of each microphone input channel. The control is turned clockwise (to the higher numbers) to increase the volume and counterclockwise to reduce it.

AUX VOLUME: This control serves a twofold purpose: it selects either of the two auxiliary inputs, and controls the volume of the selected auxiliary input. To select the AUX 1 input, rotate the control counterclockwise, past the center position. To increase the AUX 1 volume, continue to rotate the control in this direction. To select the AUX 2 input, rotate the control clockwise past the center position. To increase the AUX 2 volume, continue to rotate the control clockwise. If the auxiliary inputs are not to be used, set the control to the center position (aligning the triangle on the control with the vertical line on the front panel).

MASTER: The MASTER control is used to regulate the overall volume of the amplifier, which may include the mixed output of two or more input channels. To set this control, rotate it to the center position, then set the individual MIC and AUX controls to the highest level likely to be used and consistent with the operation of the limiter compressor. Adjust the MASTER control to the desired listening level for the mixed output.

ACCESSORIES

CAUTION

The installation of internal accessories requires the removal of the cover, which presents an electrical shock hazard. For this reason, these accessories should be installed by qualified service personnel only.

WMT-1A LINE-MATCHING TRANSFORMER: The Bogen WMT-1A Line-Matching Transformer provides an impedance match between the amplifier and a 0 level, 500/600-ohm line. This may be a telephone line connected to a switchboard for internal paging, or used with a wired music system. No soldering is required to connect the WMT-1A to the amplifier.

To connect the input from a balanced 500/600-ohm telephone line, remove the amplifier cover and mount the WMT-1A, using the mounting holes provided on the chassis (see Figure 3). Connect the input line to the three-screw terminal board on the WMT-1A. Connect the phono plug on the WMT-1A cable to the AUX 1 or AUX 2 jack on the rear of the amplifier. If these jacks are being used for other sound inputs, the WMT-1A may be connected to one of the MIC inputs. In order to do this, the WMT-1A wiring must be modified, as described in the instruction sheet supplied with the WMT-1A.

To connect the output from the amplifier to a 500/600-ohm telephone line, remove the amplifier cover and mount the WMT-1A, using the mounting holes provided in the chassis (see Figure 3). Connect the 500/600-ohm line to the three-screw terminal board on the WMT-1A. Connect the phono plug on the WMT-1A cable to the WMT-1A jack on the rear panel of the amplifier.

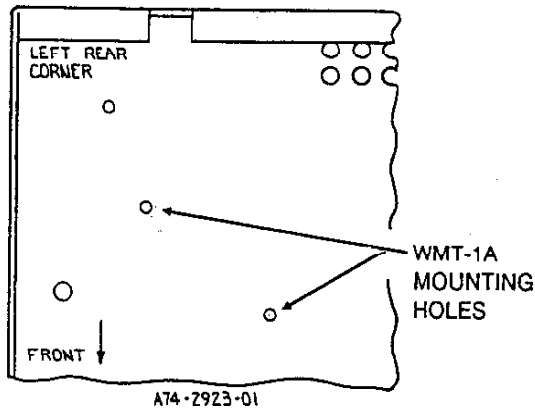

Figure 3 — Mounting Holes for WMT-1A

RVC-2B REMOTE VOLUME CONTROL: Connect the RVC-2B to the Remote Control/Precedence terminal (TS101) on the rear of the amplifier. Connect one lead from the accessory to the appropriate MIC or AUX terminal and the other lead to GND. Complete installation instructions are supplied with the RVC-2B accessory.

MODEL TG-4C MULTIPLE TONE GENERATOR: The Bogen TG-4C Multiple Tone Generator is capable of generating four distinct signals: pulsed tone, slow whoop, repeating chime, and steady tone. Each of these four signals may be applied continuously or limited to a double burst (single burst only of the steady tone) for alarm signalling or preannouncement. Signals are triggered by an external device that provides a contact closure. Both tone level and pitch are adjustable. The TG-4C may be powered from a 12-48 VDC source, or use optional Bogen Model PRS40C Power Supply for 120 VAC operation.

MODEL RPK-51 RACK PANEL KIT: The RPK-51 Rack Panel Kit is designed to mount the amplifier in a standard 19-inch sound rack. Before fitting the panel to the amplifier, remove the feet from the base of the amplifier. It is necessary to reposition the cover of the amplifier. To do so, remove four screws from each side of the amplifier; move the cover back approximately 7/8" and align the two holes at the lower edge of the cover with two predrilled holes in the chassis of the amplifier. Position the amplifier into the frame of the rack panel and secure each side by using two screws through the side panel and into the amplifier cover and chassis. Note that repositioning the cover has exposed a screw hole in the side of the amplifier, toward the front panel. Drive a screw through the third hole in the panel and into the hole in the side of the front panel on the amplifier. Repeat this procedure to secure the other side panel to the amplifier, using three screws.

Overall dimensions of the RPK-51 are 5-1/4" H x 19" W with side panels 10-3/4"D (13.3 x 48.3 x 27.3cm). Cutout dimensions are 4-1/16"H x 16-1/8"W (10.3 x 40.9 cm). The panel is fabricated from cold-rolled steel and has a black finish.

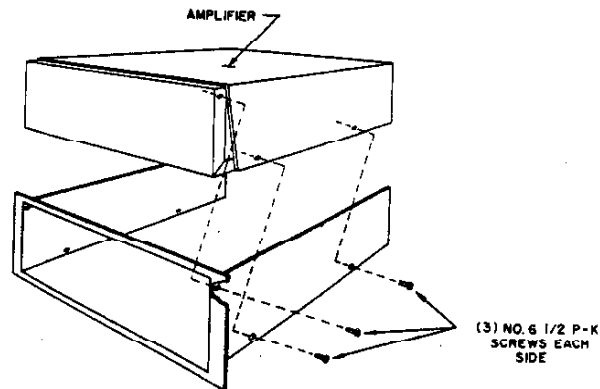

Figure 4 — Attaching Rack Panel to CT100C Amplifier

TP30D TUNER: The Bogen solid-state tuner provides FM/AM/FM Stereo (TP30D) reception of superior signal quality with precise tuning indicators. Output jacks permit connection of an amplifier and/or a tape recorder. A rack-mounting kit, Bogen Model RPK46A, is available for this unit.

MAINTENANCE

CAUTION

There are no user-serviceable parts within the amplifier. To avoid an electric shock hazard, have all internal servicing performed by qualified service personnel only. The warranty will become void if repairs are made by other than the Bogen Service Department.

CIRCUIT BREAKER

If the circuit breaker opens, the AC power lamp will go out and the amplifier will have no output. Set the AC power switch to OFF and momentarily depress the red button on the circuit breaker to reset it. Return the AC power switch to ON. If the breaker trips again, do not attempt to reset it, but have the trouble investigated by a qualified technician.

THERMAL BREAKER

If the thermal breaker opens, there will be no audio output, but the AC power lamp will remain on. Wait approximately two minutes for the breaker to reset. If the breaker resets and then opens again, investigate the cause of the temperature overload. This may be due to improper connections at the output terminals or to excessive environmental heat with inadequate ventilation. The thermal breaker will open when the temperature at the output transistor heat sink reaches 105°C (221°F).

REPLACING COMPONENTS

CAUTION

Improper soldering may damage components or the printed circuit board, and such damage can void the warranty.

Many semiconductor components are soldered in place to ensure maximum reliability. When soldering transistors or diodes, use a heat sink (such as a small alligator clip) between the component and the source of heat. Unless you are experienced in the removal of IC micromodules, do not attempt to remove them, since excessive heat can damage an IC and/or the printed circuit board. If you are certain that an IC is defective, the easiest method of removal is to cut off the leads close to the component and unsolder the leads individually. If you are not certain that an IC is defective, the use of a low-wattage, vacuum-type desoldering tool (such as Ungar Type 7800) is advised.

REPLACING TRANSISTORS

CAUTION

When soldering leads, use a heat sink (such as a small alligator clip) between the transistor and the source of heat.

When replacing the driver transistors, press a small screwdriver blade into the side of the U-clip heat sink to spread the jaws of the clip. Draw the clip and screwdriver off the metal tab on the driver transistor. Reverse the procedure to install the clip on the replacement transistor. Since the U-clip heat sink is a spring clip, avoid spreading the jaws too wide.

When replacing the output transistors, clean all foreign matter from the heat sink, insulator, and transistor. Brush a light coating of silicon compound, such as Dow Corning No. 340, to completely cover both surfaces of the insulator (Part No. 16-9278-01). Place the insulator between the heat sink and the replacement transistor. Use the original transistor mounting hardware to mount the replacement transistor.

BOGEN SERVICE

We are interested in the maintenance of your Bogen equipment. In the event of any difficulty, do not hesitate to ask our advice or assistance. Information can be obtained by writing to: Service Department, Bogen Communications, Inc., P. O. Box 575, Ramsey, NJ 07446.

When communicating with us, give the model and series designation of your unit. Describe the difficulty encountered and the effects each operating control has upon the symptoms of trouble. Include details on the electrical connections to associated equipment and list such equipment. We will send you information if the remedy appears simple. If service is required, we will send you the name and address of the nearest authorized Bogen Service Agency.

When shipping your unit, pack it well, using the original shipping carton, or a similar container, with filler material to prevent damage in transit. Send the unit, fully insured and prepaid, via UPS or any responsible carrier. It will be repaired promptly and returned to you collect (freight prepaid while in warranty).

BOGEN
COMMUNICATIONS, INC.
50 SPRING STREET, P.O. Box 575
RAMSEY, NJ 07446 (201) 934-8500