

# BOGEN<sup>®</sup>

COMMUNICATIONS, INC.

## MIXER-PREAMPLIFIER

## Model CAM

Model CAM is a fully transistorized mixer-preamplifier providing four microphone inputs and one auxiliary input, and supplying both microphone and high level outputs. While it fulfills a wide variety of applications, the CAM is particularly well suited for expanding the number of inputs of Bogen public address amplifiers.

The CAM accommodates both high and low impedance microphones, and has an input for crystal or ceramic cartridges, tuners or other high level sources. Outputs are provided for high impedance unbalanced or low impedance balanced or unbalanced microphone inputs and high level, high impedance inputs to a public address amplifier, tape deck or similar equipment. Units may be paralleled to provide a greater number of inputs.

The CAM operates from either 120VAC, 60Hz or 25-28VDC source. It may be mounted in a standard 19" equipment rack using Bogen RPK35B Rack Mounting Kit or in a wall with Model WMK-1 In-Wall Mounting Kit.

## INSTALLATION

### UNPACKING

Your unit was carefully checked before leaving the factory. Inspect the shipping container and the unit carefully for indications of improper handling. If the unit has been damaged, make an immediate claim to the distributor from whom it was purchased. If it was shipped to you, notify the transportation company and place a claim.

### POWER and GROUNDING

The AC line cord has a three-prong plug which should be plugged into a three-wire, grounded 120V, 60 Hz outlet. If a three-wire outlet is not available, use an adapter and secure the pigtail lead to the grounded wall plate mounting screw. *It is important to ground the unit.* If the wall plate screw is not grounded, connect a wire from the GND terminal of the mixer/preamplifier to a suitable earth ground.

#### Auxiliary power

A 24 to 28V external DC supply may be used to power the unit and may remain connected when the unit is being powered by the primary AC source. The power switch, when set to off, disconnects both AC and DC supplies, turning the unit off.

## INPUT CONNECTIONS

### HIGH IMPEDANCE MICROPHONES

High-impedance microphones (approximately 20K to 50K ohms) may be connected to any of the four MIC inputs. The microphone lead should be a single-conductor shielded cable terminated in a standard 3-pin microphone connector (Cannon XLR-311C, or equivalent). See figure 1.

### LOW IMPEDANCE MICROPHONES

Model CAM will also accommodate low impedance microphones directly. Use two-conductor shielded cable terminated in a standard 3-pin microphone connector, as shown in figure 1.

### AUXILIARY INPUT

One auxiliary input is provided for high-level, high-impedance inputs, such as a radio tuner, tape player, or turntable utilizing a ceramic cartridge. An input signal of 0.125 volt is required to obtain a full output (2.5V) from the preamplifier.

Use single-conductor shielded cable terminated in an RCA phono plug for connecting auxiliary equipment. If hum is experienced after making connections, connect a ground wire between the chassis of the auxiliary unit and the GND terminal of the CAM.

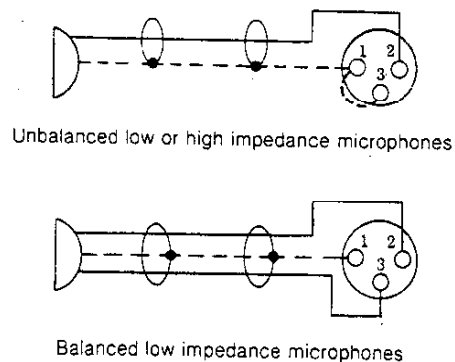
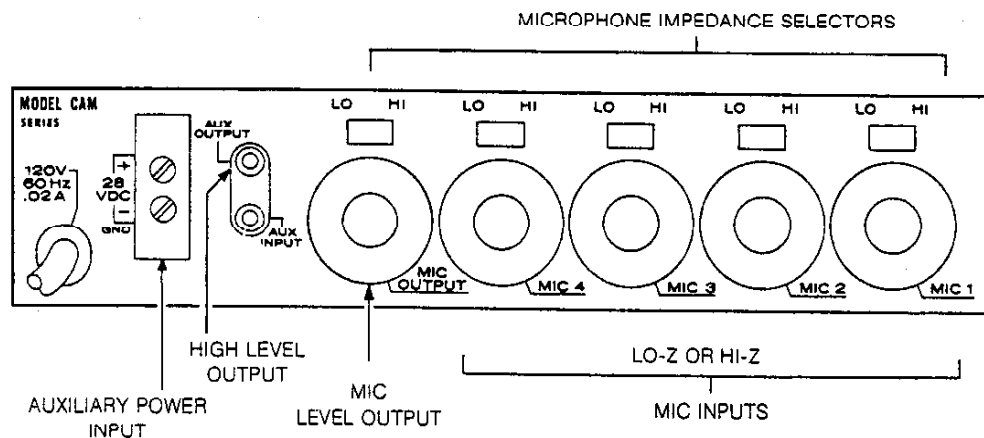

Figure 1 — Connecting microphone cables

## TECHNICAL SPECIFICATIONS

<b>Rated output</b>	2.5V Hi-Z output; 125 mV Hi-Z MIC output; 12.5 mV Lo-Z MIC output		
<b>Output impedance</b>	Lo-Z MIC 25-600 ohms, balanced or unbalanced; Hi-Z MIC 20,000 ohms, (or higher) unbalanced; Hi-Z AUX output 50,000 ohms (or higher) unbalanced		
<b>Frequency response</b>	Flat $\pm 2$ dB, 20-20,000 Hz		
<b>Hum &amp; Noise</b>	MIC 70 dB below rated output; AUX 80 dB below rated output; MASTER 90 dB below rated output		
<b>Distortion</b>	Less than 1% at rated output		
<b>Equivalent input noise</b>	-123 dB/V		
<b>Inputs</b>	4 balanced or unbalanced Lo-Z MIC or HI-Z unbalanced MIC, 1 AUX		
<b>Gain</b>	<i>Lo-Z MIC output</i>	<i>Hi-Z MIC output</i>	<i>Hi-Z output</i>
<i>Lo-Z MIC/300 <math>\mu</math>V</i>	+10 dB/1mV	+30 dB/10mV	+66 dB/600mV
<i>Hi-Z MIC/3mV</i>	-10 dB/1mV	+10 dB/10mV	+46 dB/600mV
<i>AUX/30mV</i>	-30 dB/1mV	-10 dB/10mV	+26 dB/600mV
<b>Semiconductors</b>	All silicon; 16 transistors, 2 diodes		
<b>Controls</b>	4 MIC volumes, 1 AUX volume, 1 MASTER volume, 1 POWER switch, 4 mic input impedance selectors, 1 mic output impedance selector		
<b>Input/output connections</b>	Microphone: professional 3-pin audio connectors (male); Aux/Hi-Z: standard phono jack		
<b>Power consumption</b>	120VAC, 60 Hz, .02A; 24-28VDC, .01A		
<b>Dimensions</b>	11 $\frac{1}{8}$ " W x 2 $\frac{1}{2}$ " H x 7 $\frac{1}{4}$ " D (28.9 x 7.3 x 19.7 cm)		
<b>Weight</b>	4 lbs. (1.8 kg)		



C74-2355-01

Figure 2 — CAM, rear chassis

## OUTPUT CONNECTIONS

### AUX OUTPUT

This output may be used to interconnect equipment with a high-level, high-impedance input, such as the auxiliary input of an amplifier or booster. Use single-conductor shielded cable terminated in an RCA phono plug to connect the output to other equipment.

### MICROPHONE LEVEL OUTPUT

The CAM output can be connected to the microphone input of another preamplifier or amplifier. Connections are made with standard microphone cables and appropriate connectors.

### MIC OUTPUTS

Connections for high-impedance/low-impedance unbalanced outputs and low-impedance balanced outputs are illustrated in figure 3. Use single conductor shielded cable for unbalanced outputs and two-conductor shielded cable for balanced outputs, terminated in a Cannon XLR-311 connector, or equivalent.

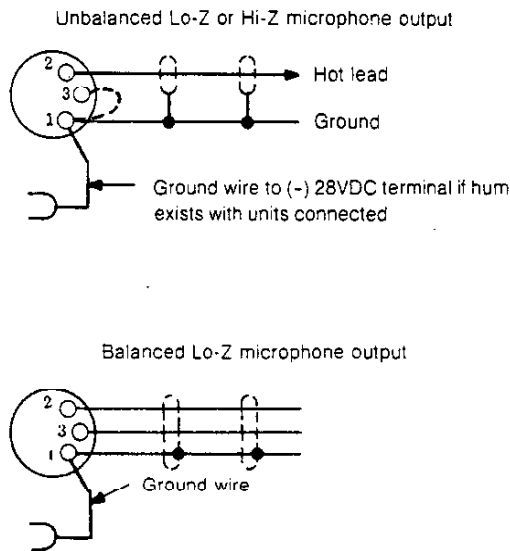

Figure 3 — Microphone output connections

### OTHER CONNECTIONS

The CAM may be used to increase the number of inputs of any public address amplifier. Use either the AUX or MIC outputs of the CAM and connect to the similar input of the amplifier. See figure 4.

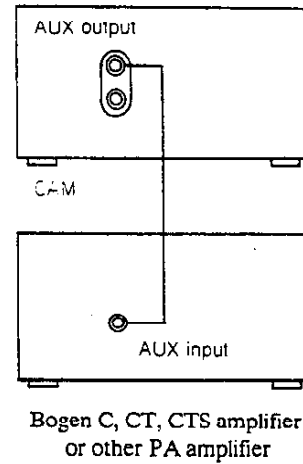

Figure 4 — Single connection for increased inputs

Units may be connected in series to increase the number of inputs. Connection is made with single-wire shielded cable from the AUX output of one CAM to the AUX input of the next. Care must be taken to adjust the AUX and MASTER controls on units connected this way to arrive at equal levels from all microphone inputs. See figure 5.

Up to four additional units may be cascade-connected to provide up to 16 additional microphone outputs. Use two-conductor shielded cable and make connections as shown in figure 7. Connect the AUX output to Bogen C, CT, CTS or equivalent PA amplifier.

High or low impedance MIC outputs may be paralleled directly to supply a MIC input on a following amplifier or preamplifier. See figure 8.

*Note*  
If hum is introduced when units are connected, it may be necessary to connect a ground wire from chassis to chassis. The negative DC supply terminal is ground on the CAM.

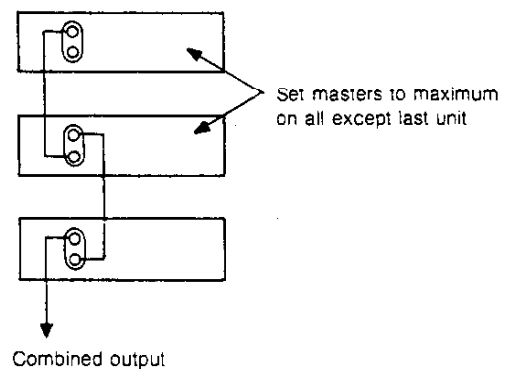

Figure 5 — Series-connected outputs

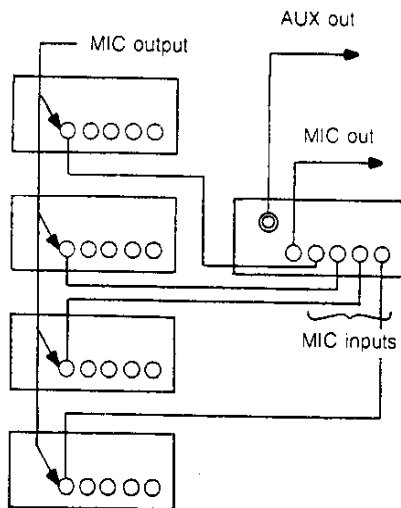

Figure 7 — Cascade-connected outputs

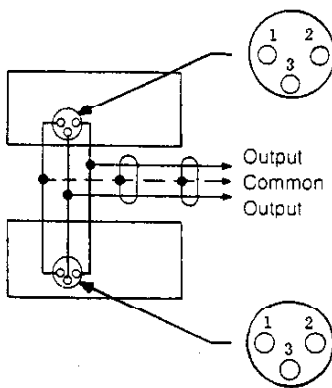

Figure 8 — Paralleled microphone outputs

## CONTROL OPERATION

### POWER

This switch applies power to the unit. The POWER indicator lamp will light to indicate power on when connected to an AC power source.

### MASTER

This control regulates the overall volume of the preamplifier, which may include the mixed output of two or more input channels. To set this control, rotate it clockwise to the maximum position, then set the individual MIC and AUX controls to the highest anticipated level of use. Re-adjust the MASTER control to the desired listening level for the mixed output.

### MIC VOLUME

The four MIC volume controls are used to adjust the level of individual microphone input channels. Rotate these controls clockwise (to the higher numbers) to increase volume and counter-clockwise to reduce volume.

### AUX VOLUME

Controls the AUX input volume and functions the same as the MIC volume controls.

## ACCESSORIES

### RPK35B RACK PANEL

Bogen Model RPK35B Rack Panel is designed to mount the CAM in a standard 19-inch sound equipment rack. The panel is fabricated from cold-rolled steel and finished in black enamel.

### WMK-1 IN-WALL MOUNTING KIT

Bogen Model WMK-1 is designed to mount the Mixer-Preamplifier flush in a wall. Depth of the mounted unit is 3½ inches.

## MAINTENANCE

### Caution

*There are no user-replaceable parts within the unit. All internal servicing should be performed by qualified service personnel.*

### BOGEN SERVICE

We are interested in the maintenance of your Bogen equipment. If trouble develops, do not hesitate to ask our advice. Information can be obtained by writing to: Service Department, Bogen Communications, Inc., 50 Spring Street, Ramsey, NJ 07446.

When communicating with us, give the model and series designation of the unit. Describe the difficulty and include details on the electrical connections to associated equipment. We will send you service information if the trouble appears to be minor. If the trouble requires servicing, you can ship the unit to the Bogen factory for service.

If you ship the unit, pack it well, preferably in the original shipping container. Send the unit fully insured and prepaid by UPS or other responsible carrier. It will be promptly repaired and returned to you.