

6-6. STARTER REPAIR

This task covers:

- a. Removal
- b. Cleaning
- c. Inspection
- b. Assembly
- e. Bench Testing and Adjusting

INITIAL SETUP:

Tools

General mechanic's tool kit:
automotive (Appendix G, Item 1)

Test Equipment

Switch (Appendix G, Item 91)
Multimeter (Appendix G, Item 120)
Carbon pile (Appendix G, Item 92)
Armature test set (Appendix G, Item 93)

Materials/Parts

Pinion stop and snapping kit
(Appendix E, Item 125)
Thrust washer and spacer kit
(Appendix E, Item 209)
Gasket set (Appendix E, Item 41)
Gasket set (Appendix E, Item 42)
Core parts kit (Appendix E, Item 7)
Gasket kit, commutator end head
(Appendix E, Item 40)

Materials/Parts (Cont'd)

Two locknuts (Appendix E, Item 50)
Pinion O-ring (Appendix E, Item 120)
Washer kit (Appendix E, Item 213)
Adhesive-sealant (Appendix B, Item 2)
Aircraft grease (Appendix B, Item 20)
Lithium grease (Appendix B, Item 22)
Lubricating oil (Appendix B, Item 32)
Core shaft nut tool (Appendix C, Fig. 3)

Manual References

TM 9-2320-280-20
TM 9-2320-280-24P

Equipment Condition

Starter removed (TM 9-2320-280-20).

Maintenance Level

Direct support

a. Disassembly

1. Remove plug (4) and gasket (5) from pinion housing (3). Discard gasket (5).
2. Using core shaft nut tool, remove locknut (2) from end of core shaft (1) located inside pinion housing (3). Discard locknut (2).

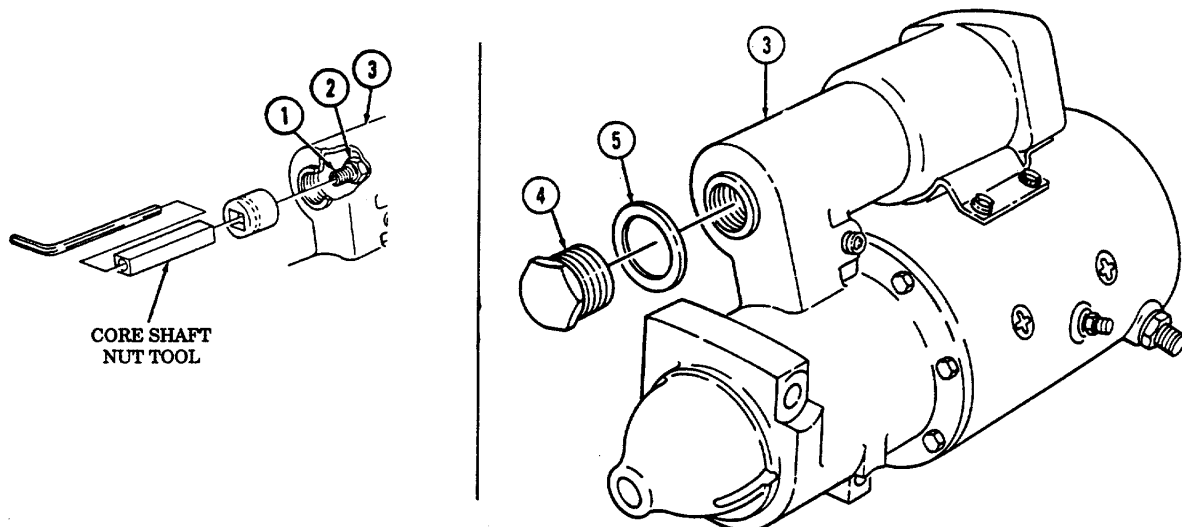

6-6. STARTER REPAIR (Cont'd)

3. Remove four nuts (6), lockwashers (7), and two solenoid lead connectors (8) from frame and field assembly (9) and solenoid (11). Discard lockwashers (7).
4. Remove four capscrews (10) and solenoid (11) from frame and field assembly (9).
5. Scribe a locating mark (12) on commutator end head (16) and frame and field assembly (9).
6. Remove four capscrews (15), commutator end head (16), and gasket (17) from frame and field assembly (9). Discard gasket (17).
7. Remove thrust washer(s) (14) and spacer (13) from armature shaft (19). Discard spacer (13) and thrust washer(s) (14).
8. Remove oil felt washer (18) from commutator end head (16). Discard felt washer (18).

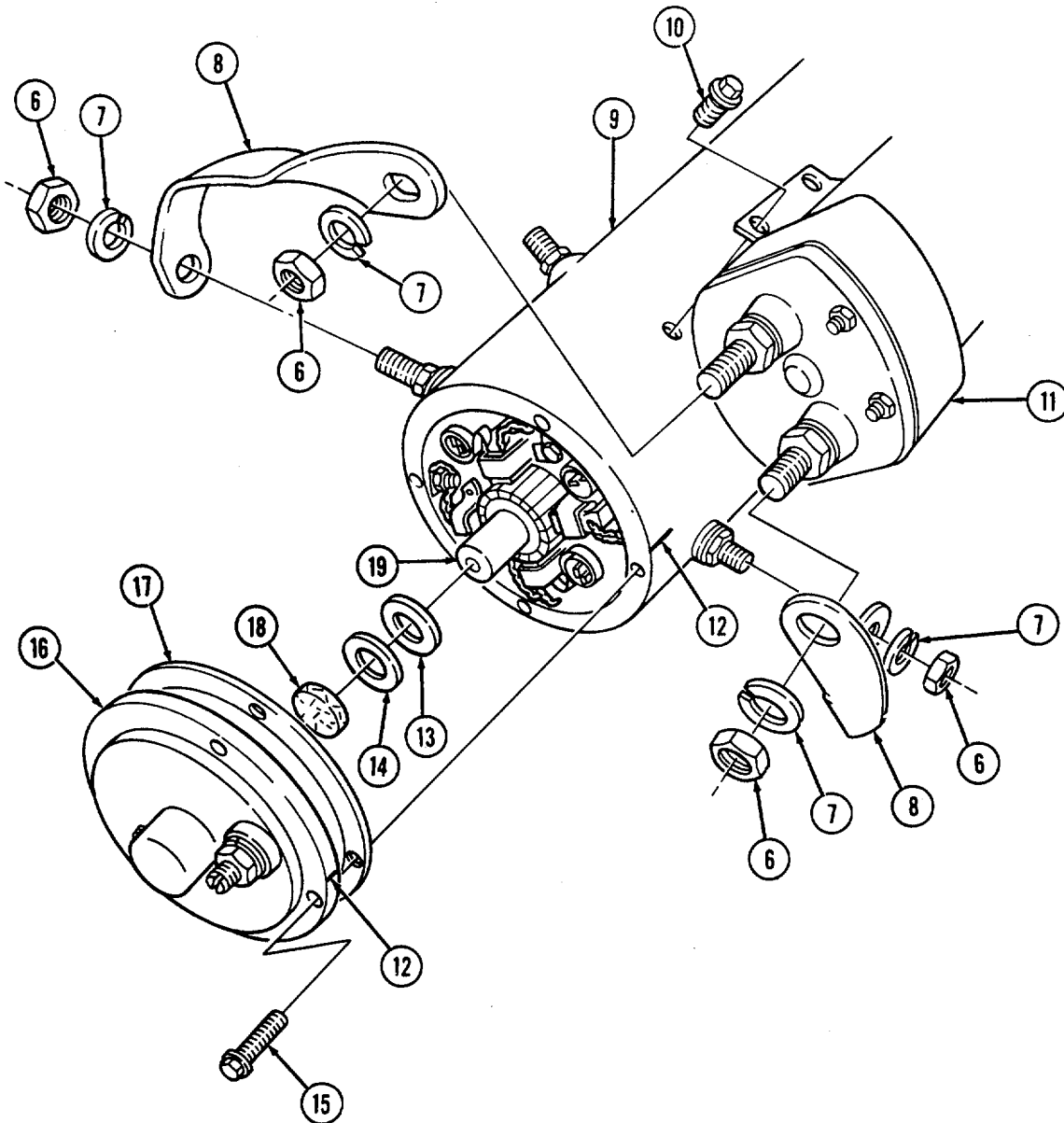

6-6. STARTER REPAIR (Cont'd)

9. Scribe a locating mark (4) on pinion housing (1) and starter motor frame (3).
10. Remove seven capscrews (6), starter motor frame (3), gasket (5), and O-ring (2) from pinion housing (1). Discard gasket (5) and O-ring (2).
11. Remove two plugs (9) and pin (10) from shift lever (8) and pinion housing (1).

NOTE

Armature and shift lever must be positioned as shown for removal from pinion housing.

12. Clamp pinion housing (1) in vise and remove three screws (17) from pinion housing (1). Slide armature (7) and shift lever (8) out from pinion housing (1).
13. Remove snapping (11) and pinion stop (12) from armature shaft (15) and slide clutch (13) off armature shaft (15). Discard snapping (11) and pinion stop (12).
14. Remove washer (14), pinion housing end plate (18), and washer (16) from armature shaft (16). Discard washers (14) and (16).
15. Remove gasket (19) from pinion housing end plate (18) and discard gasket (19).

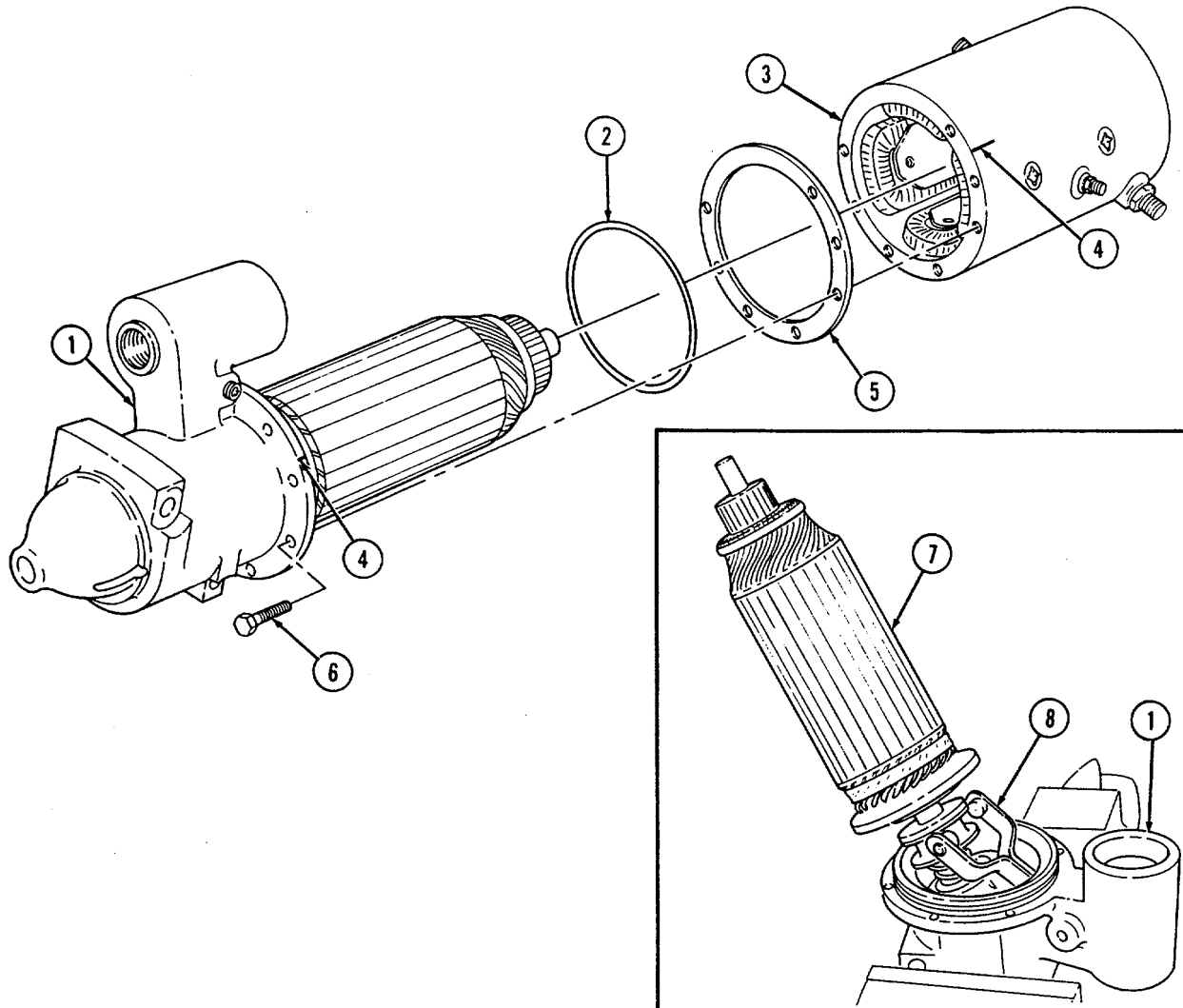

6-6. STARTER REPAIR (Cont'd)

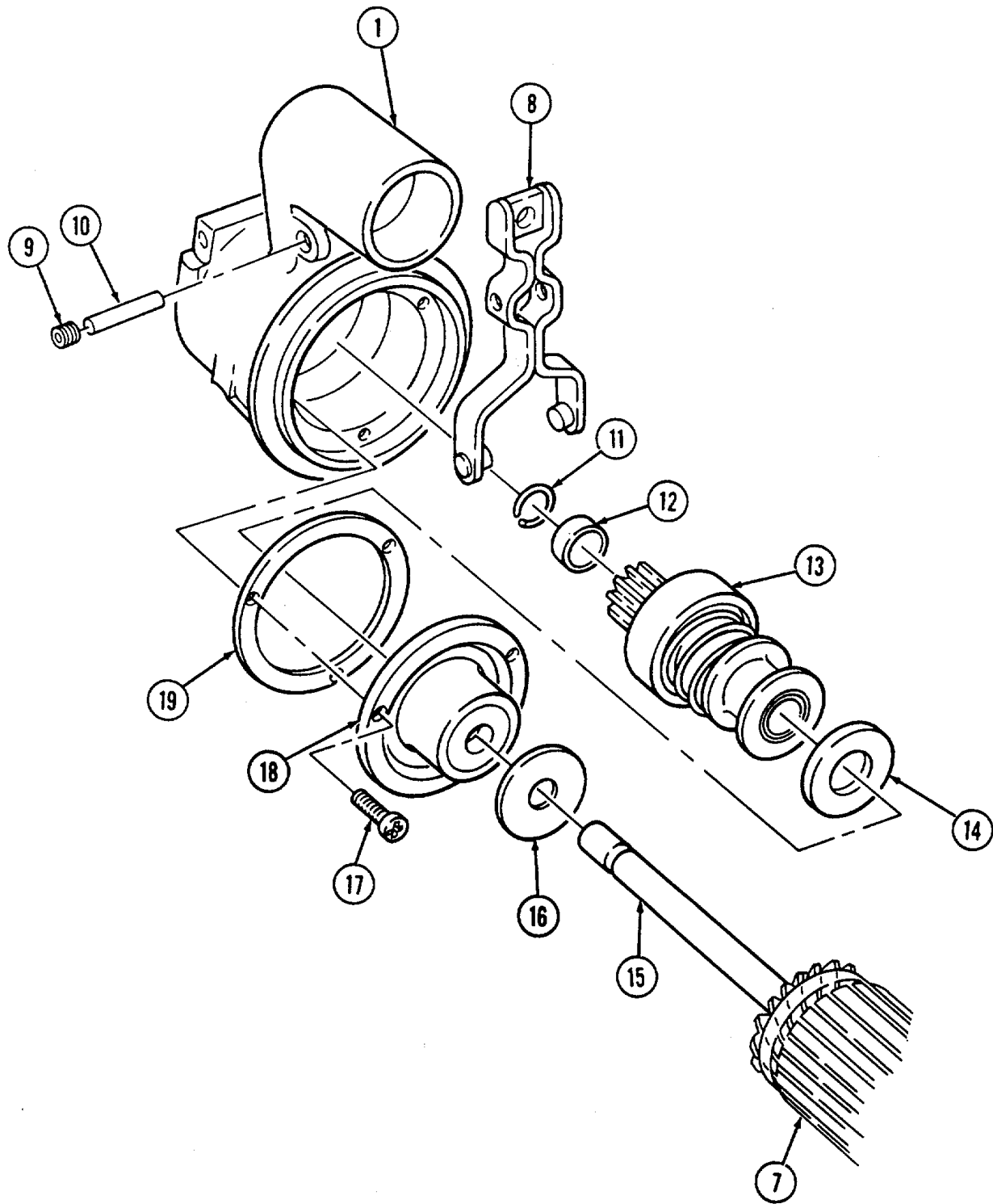

6-6. STARTER REPAIR (Cont'd)

16. Remove two nuts (12), lockwashers (11), screws (8), copper washers (7) and two negative brush leads (10) from starter motor frame (4). Disconnect two negative brush leads (10) and remove two brushes (9). Discard two lockwashers (11).
17. Remove two screws (1) and two positive brush leads (2) from field coil (3).
18. Remove four springs (5) from brush holders (6).
19. Remove four nut and lockwasher assemblies (14), rubber washers (15), and cover (16) from solenoid housing (18). Pull cover (16) away from solenoid housing (18) far enough to allow access to series winding connection (19) and screw (20). Discard rubber washers (15) and nut and lockwasher assemblies (14).
20. Remove screw (20) and washer (21) from series winding connection (19) on cover (16). Remove cover (16) and gasket (17) from solenoid housing (18). Discard gasket (17).
21. Hold core shaft (27) and remove locknut (26), washer (25), and contact (24) from core shaft (27). Remove core shaft (27), washer (22), and spring (23) from solenoid housing (18). Discard locknut (26).
22. Remove snapping (31), spring retainer (30), spring (29), spring retainer (28), rubber boot (32), and washer (33) from core shaft (27). Discard snapping (31).

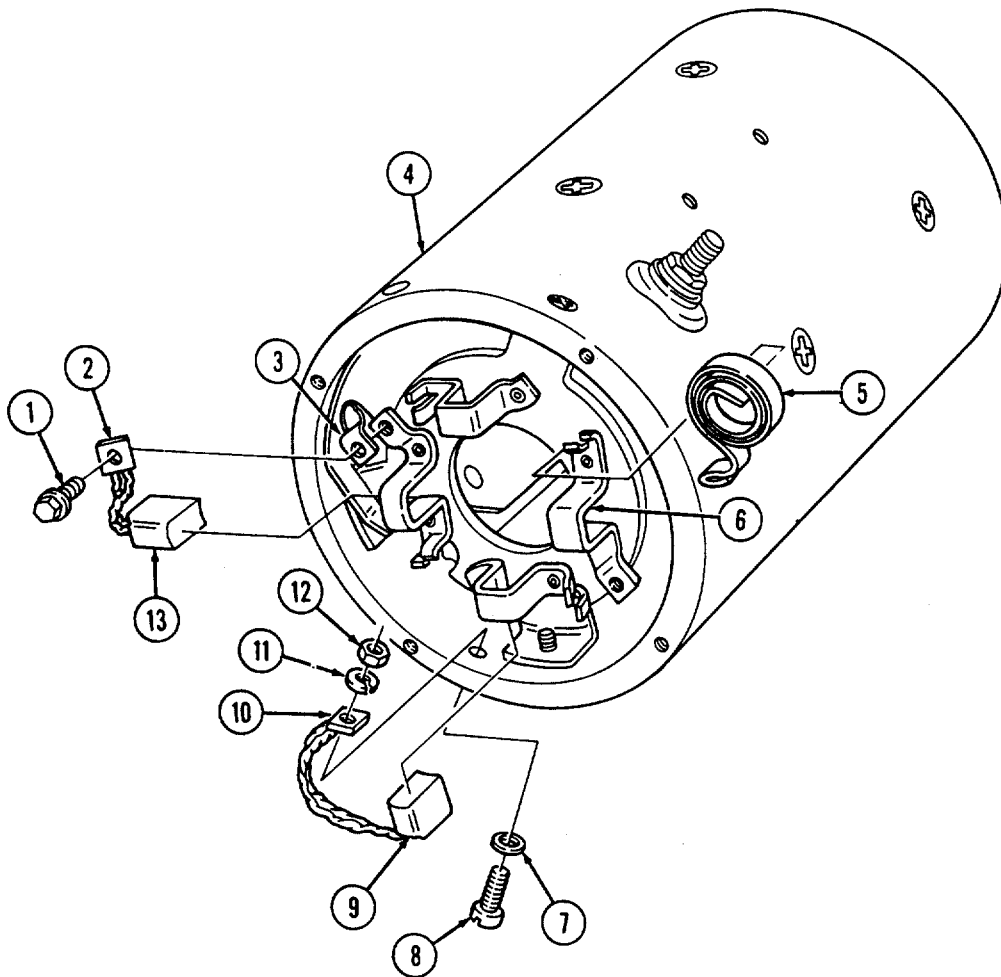

6-6. STARTER REPAIR (Cont'd)

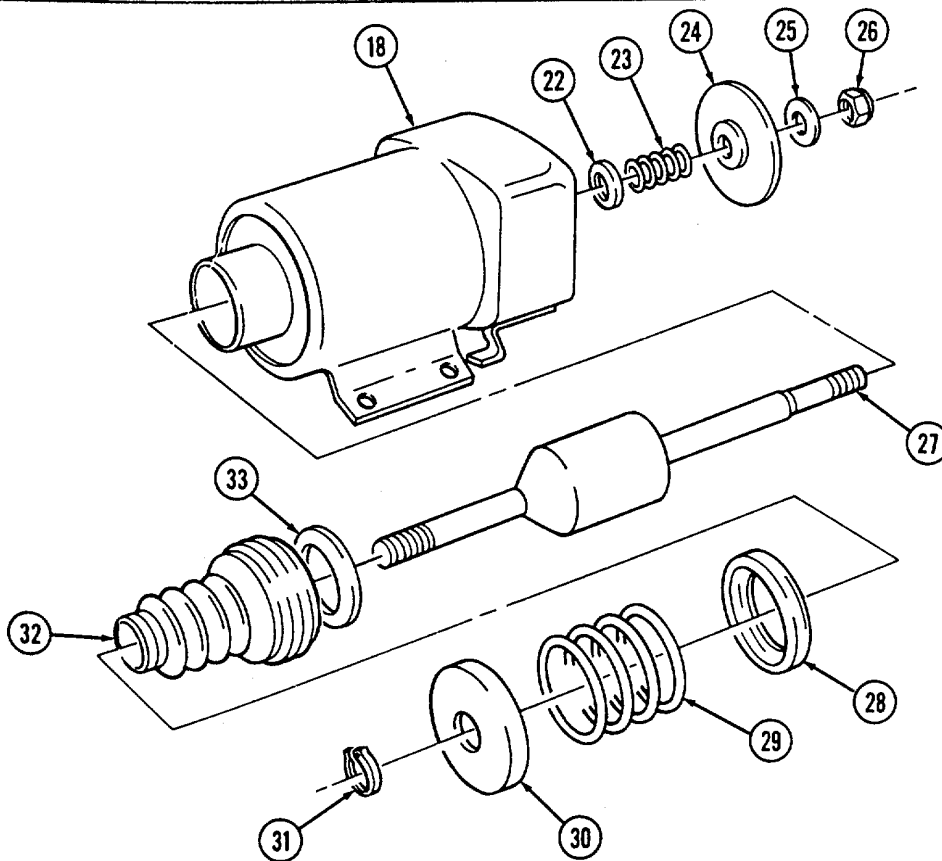
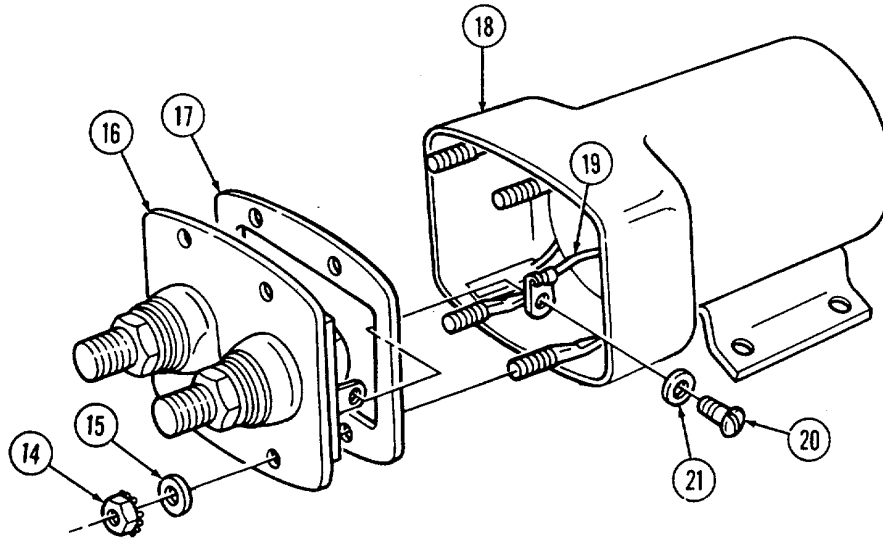

6-6. STARTER REPAIR (Cont'd)

b. Cleaning

Clean all starter motor components in accordance with para. 2-13.

c. Inspection

NOTE

For general inspection instructions, refer to para. 2-14.

1. Inspect clutch (7) for damage, roughness, or damaged gear. Replace clutch (7) if defective.
2. Check the brushes (4) for roughness, galling, and wear. Replace brushes (4) if defective. Replace any brushes (4) if brush length is less than 0.375 in. (9.52 mm).
3. Check the brush springs (5) for damage. Replace brush springs (5) if damaged.
4. Inspect end head bearing (1) for roughness, galling, or damage. Replace end head bearing (1) if defective.
5. Inspect pinion housing (6) for pitting, cracks, or damage. Inspect inside diameter of bearing (6.1) for pitting, cracks, or visual evidence of elongation. If pinion housing (6) or bearing (6.1) is damaged, replace both pinion housing (6) and bearing (6.1).
6. Check the commutator (10) for damage or evidence of excessive arcing. Inspect the armature shaft (11) for rough bearing surfaces and rough or damaged splines (8). Replace starter motor if defective.
7. The armature (9), field coils (3), and brush holder (2) should be checked for shorts, grounds, and open circuits with armature test set. Replace starter motor if armature (9), field coils (3), or brush holder (2) is defective.
8. Inspect core spring (20) and rubber boot (23) for damage. Replace if damaged.
9. Inspect contact (15) for burns or damage. Replace if burned or damaged.

d. Assembly

NOTE

For general assembly instructions, refer to para. 2-16.

1. Install washer (24), rubber boot (23), spring retainer (19), spring (20), and spring retainer (21) on core shaft (18) with retaining ring (22).
2. Install core shaft (18), washer (13), spring (14), contact (15), and washer (16) into solenoid housing (12). Hold core shaft (18) and install locknut (17).

6-6. STARTER REPAIR (Cont'd)

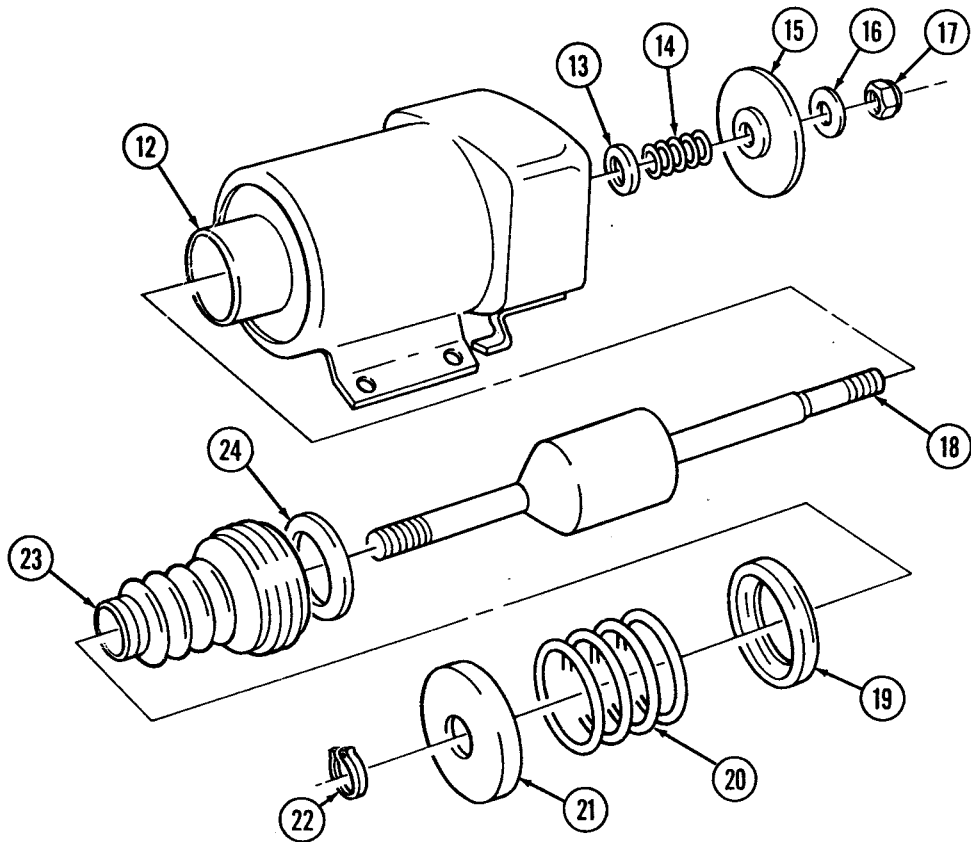
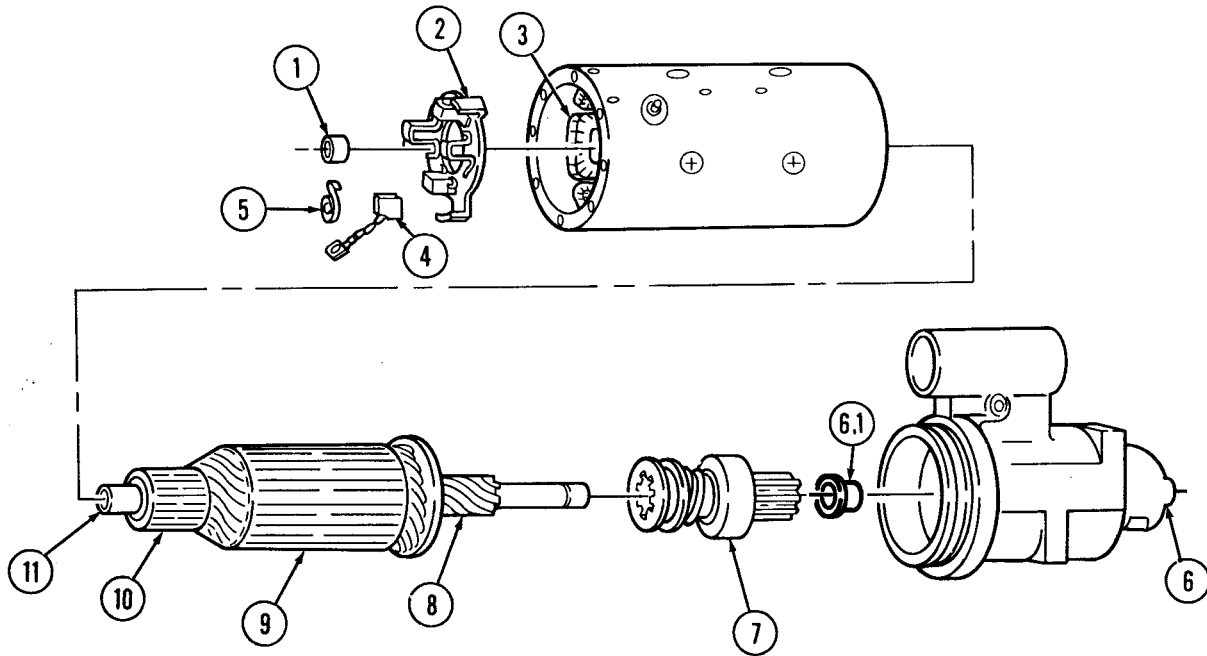

6-6. STARTER REPAIR (Cont'd)

3. Install gasket (1) on solenoid housing (2) and connect series winding connection (6) in cover (9) with series winding connection (5) in solenoid housing (2) with washer (4) and screw (3).
4. Install cover (9) on solenoid housing (2) with four rubber washers (7) and nut and lockwasher assemblies (8).

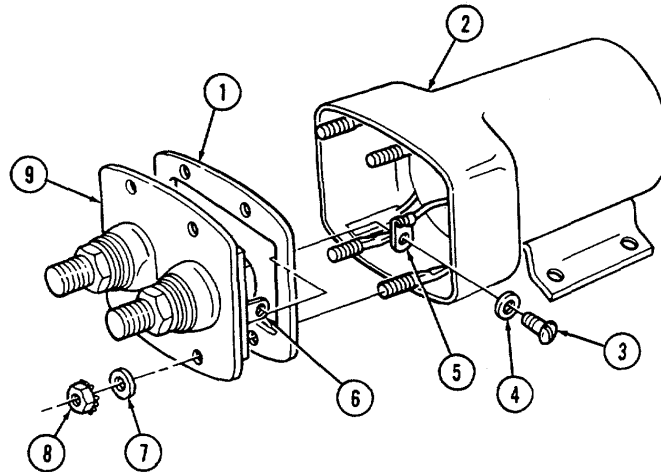

5. Install two negative brushes (18) and two positive brushes (22) on four brush holders (15) with springs (14).
6. Connect two positive brush leads (11) to field coil (12) with two screws (10).
7. Connect two negative brush leads (19) to frame and field assembly (13) with two screws (17), copper washers (16), lockwashers (20), and nuts (21). Cover heads of screws (17) with adhesive-sealant.

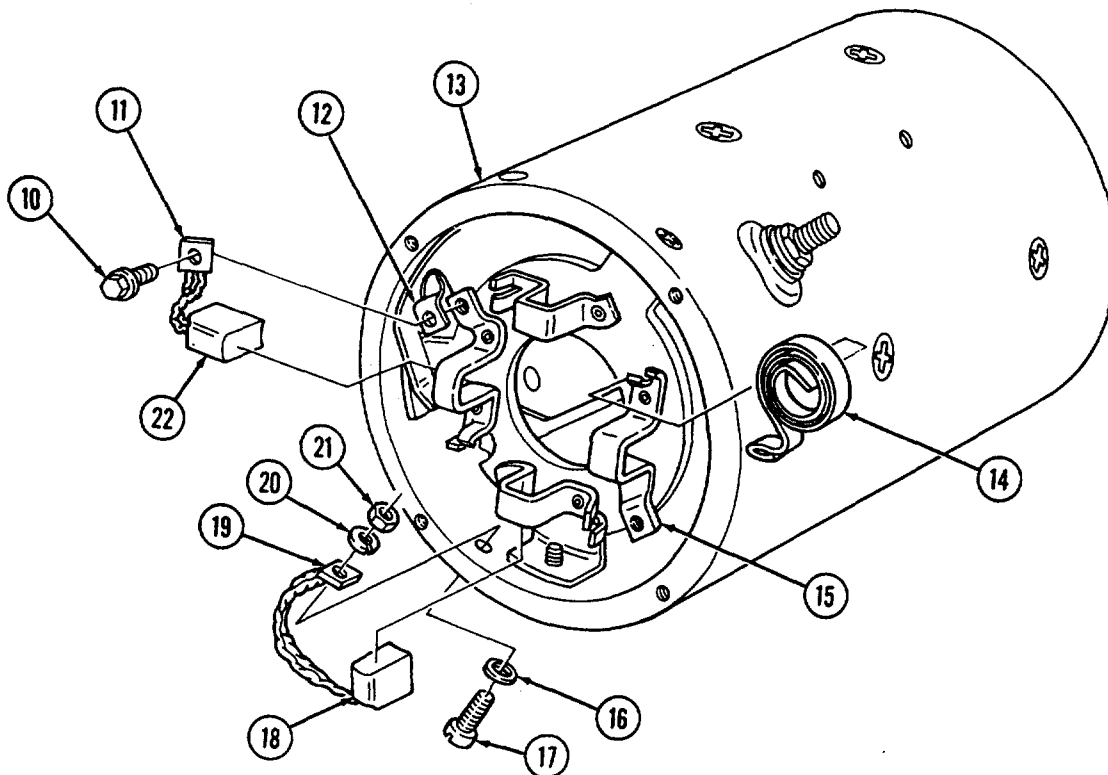

6-6. STARTER REPAIR (Cont'd)

8. Apply aircraft grease to armature shaft (32), shift lever studs (26), and the inside diameter of end plate seal (34).
9. Install washer (33), pinion housing end plate (36), gasket (37), and washer (30) on armature shaft (32).
10. Install clutch (29) on armature shaft (32) with pinion stop (28) and snapping (27).

NOTE

Armature and shift lever must be positioned as shown for installation into pinion housing.

11. Install shift lever (25) and armature (31) into pinion housing (38). Install pinion housing end plate (36) on pinion housing (38) with three screws (35). Tighten screws (35) to 40 lb-in. (5 Nm).
12. Install shift lever (25) on pinion housing (38) with pin (24) and two slugs (23).

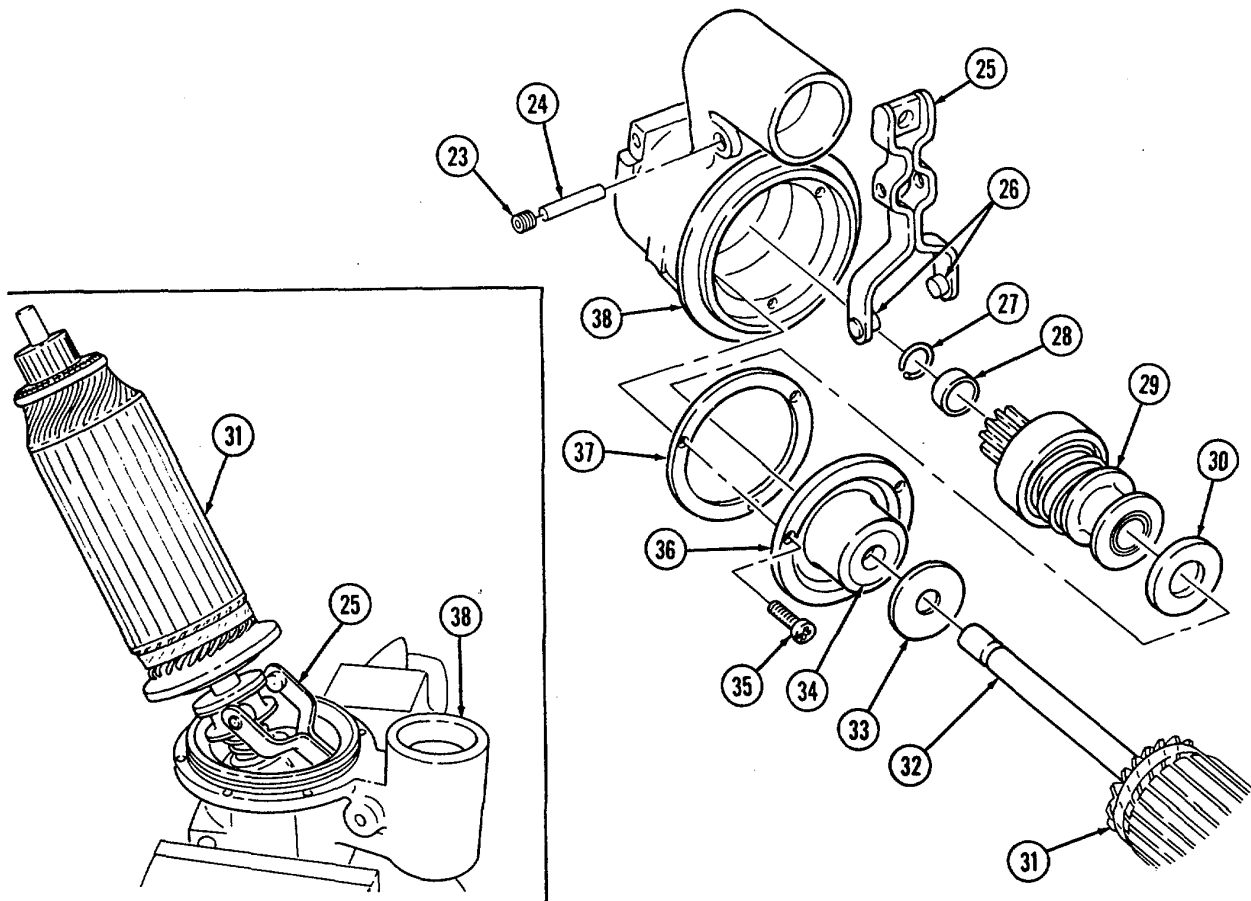

6-6. STARTER REPAIR (Cont'd)

13. Install gasket (6) and O-ring seal (3) on pinion housing (1) and align locating scribe marks (5) on pinion housing (1) and frame and field assembly (4).
14. Coat threads of capscrews (7) with adhesive-sealant.
15. Install armature (2) into frame and field assembly (4) and position brushes (9) on armature (2). Secure pinion housing (1) to frame and field assembly (4) with seven capscrews (7). Tighten capscrews (7) to 50 lb-in. (6 N·m).
16. Saturate felt washer (13) with lubricating oil and install into commutator end head (12).
17. Install spacer (15) and thrust washer(s) (14) on armature shaft (16).
18. Align locating marks (8) on commutator end head (12) and frame and field assembly (4).
19. Coat threads of capscrews (11) with adhesive-sealant.
20. Install commutator end head (12) and gasket (10) on frame and field assembly (4) with four capscrews (11). Tighten capscrews (11) to 25 lb-in. (3 N·m).
21. Coat threads of capscrews (18) with adhesive-sealant. Coat ribbed area of boot (19) with lithium grease.
22. Install solenoid (17) on frame and field assembly (4) with four capscrews (18). Tighten capscrews (18) to 50 lb-in. (6 N·m).

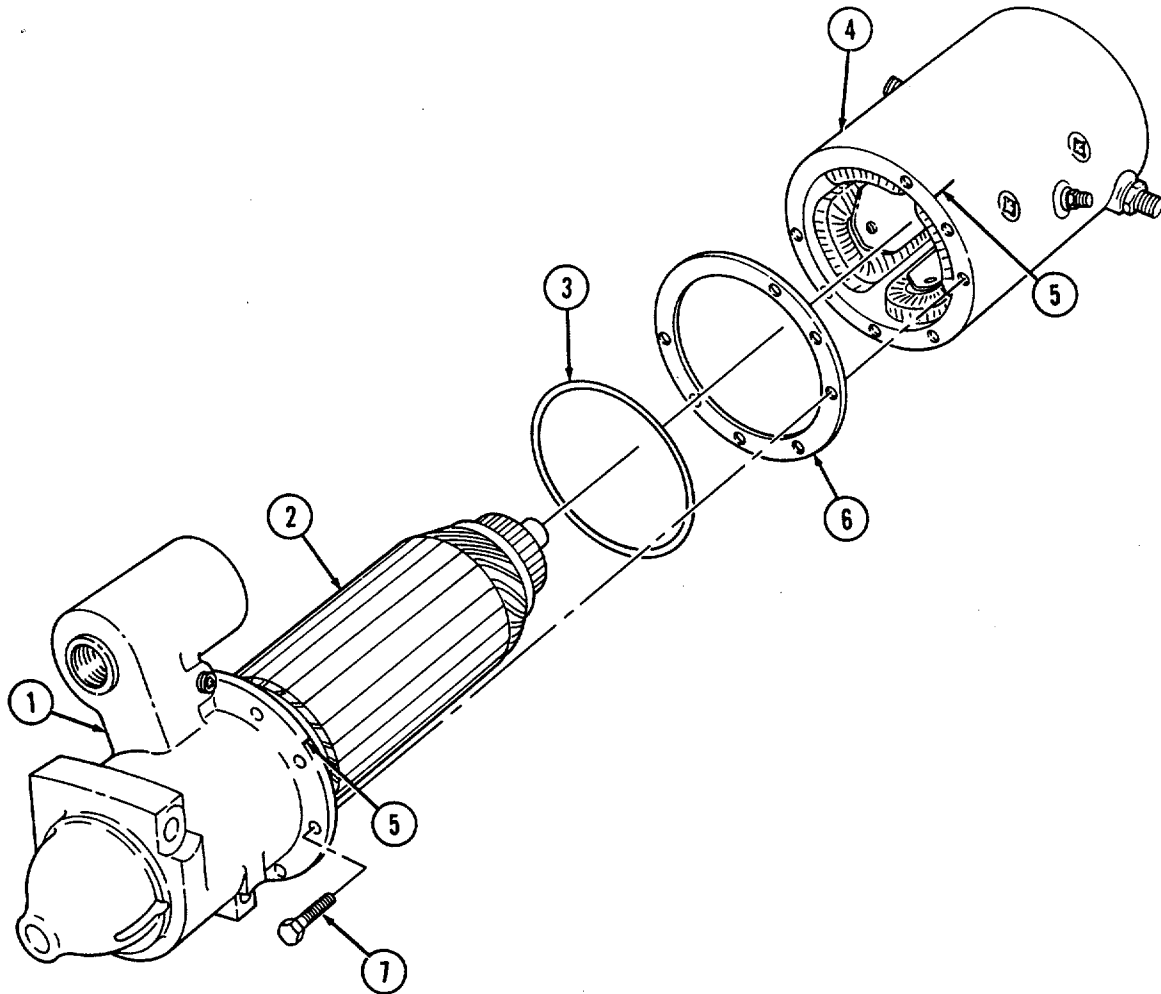

6-6. STARTER REPAIR (Cont'd)

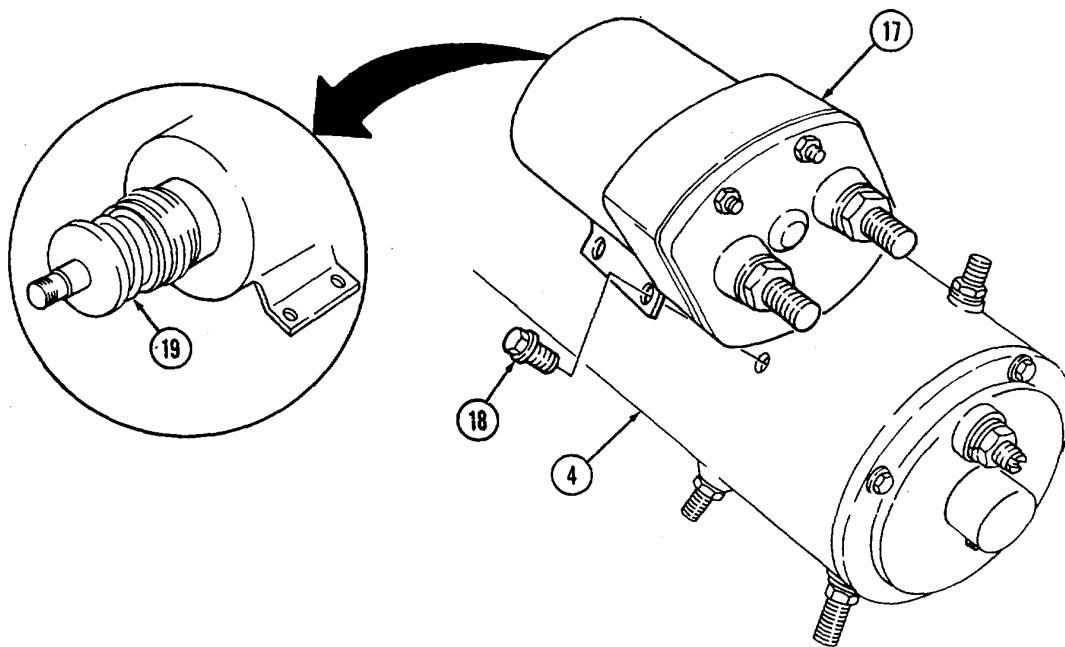
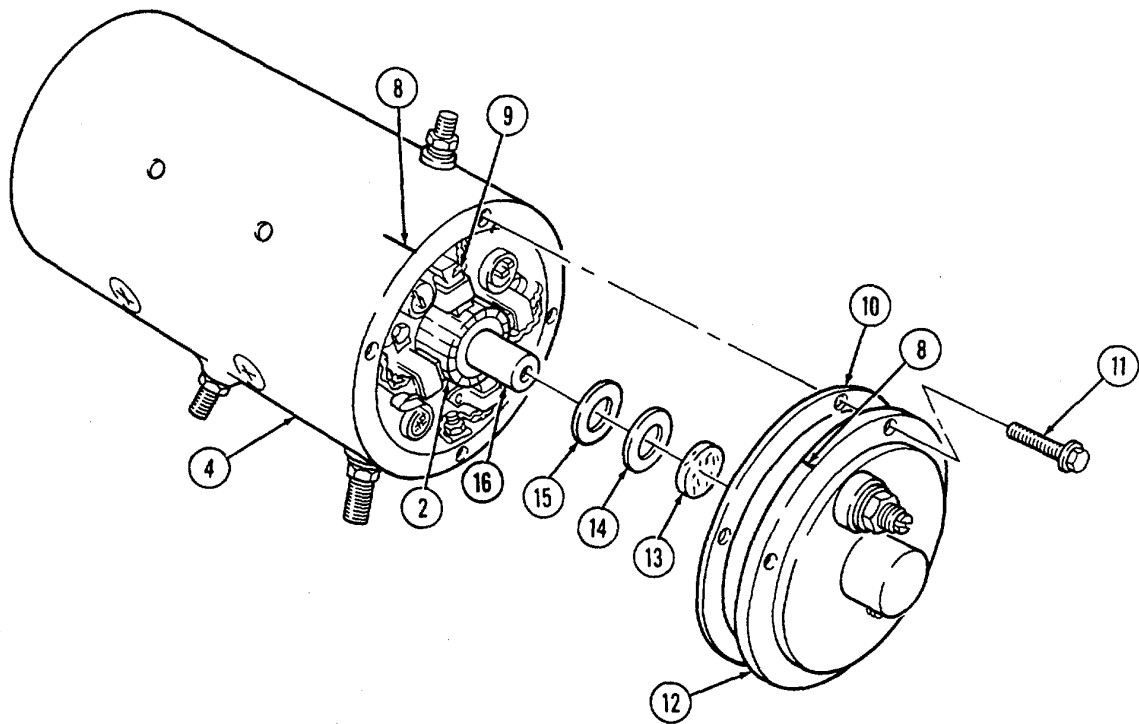

6-6. STARTER REPAIR (Cont'd)

23. Using core shaft nut tool, install locknut (2) on core shaft (1).

c. Installation

e. Bench Testing and Adjustment

1. Adjust armature end play 0.005-0.030 in. (0.127-0.762 mm) by adding or removing thrust washer(s) (3) on commutator end of armature shaft (4).
2. Connect 12-volt (not 24-volt) supply to starter motor (6). Momentarily connect jumper lead (5) as shown. This will shift clutch (7) into cranking position until battery is disconnected.
3. Push clutch (7) towards commutator end of starter motor (6) to eliminate slack. Measure distance between outside edge of clutch (7) and pinion stop (8). End play must be 0.020-0.050 in. (0.508-1.27 mm). Adjust end play by turning core shaft locknut (2) in or out.

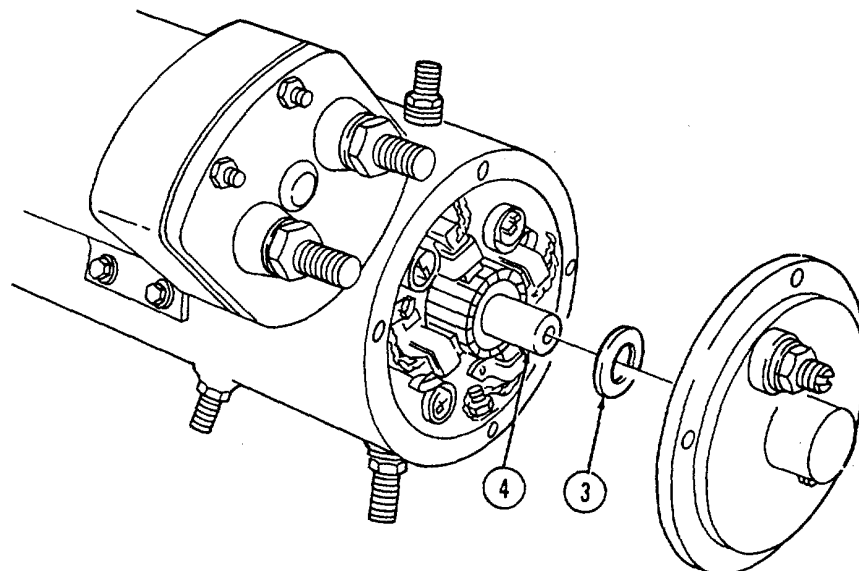
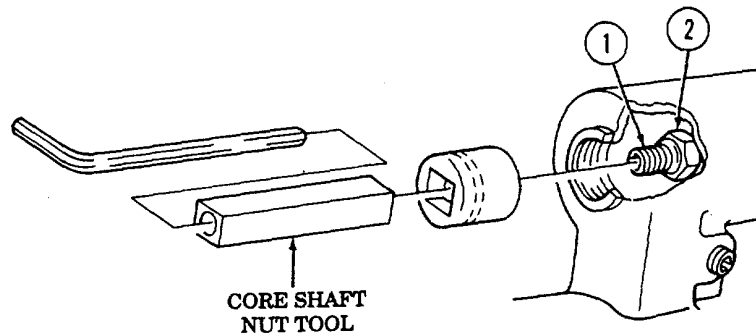

6 - 6. STARTER REPAIR (Cont'd)

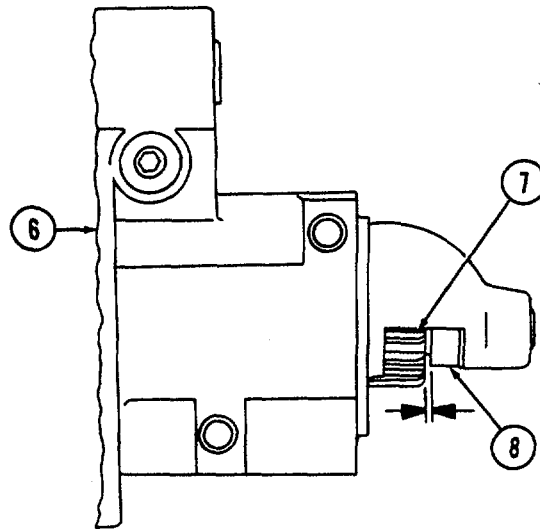
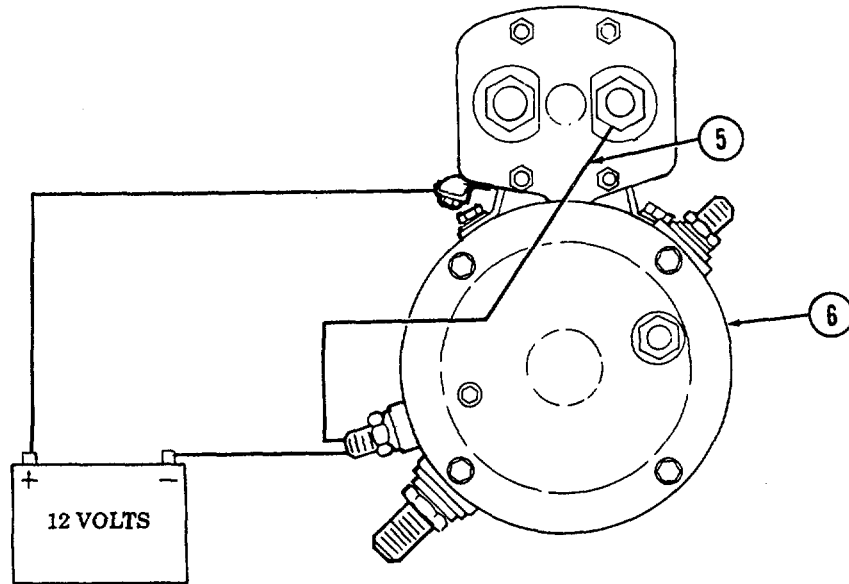

6 - 6. STARTER REPAIR (Cont'd)

4. Install gasket (2) and plug (1) on pinion housing (3).
5. Install two solenoid lead connectors (7) on solenoid terminals (8) and starter motor terminals (4) with four lockwashers (5) and nuts (6).

