

AMPCO INSTALLATION INSTRUCTIONS

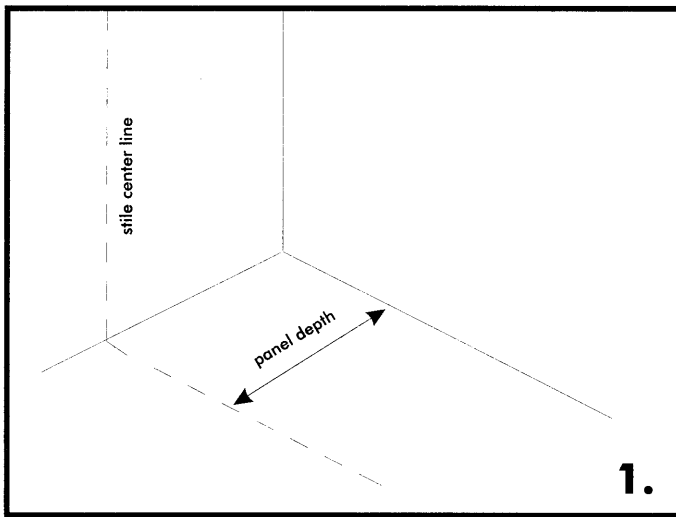

TOILET COMPARTMENTS

Floor Mounted and Overhead Braced Construction
High Pressure Laminate, Melamine,
Powder-Coated Baked Enamel,
Solid Surface Veneer, Stainless Steel



These instructions are current as of April, 2000. Ampco reserves the right to modify the procedure. Please contact Ampco with questions or discrepancies before proceeding with installation.

Determine the depth of the toilet compartment from the shop drawings. Subtract 5/8" from this measurement. Mark this depth and snap chalk lines as illustrated. These lines will be the center line for the wall brackets and the stile. (Note: the actual panel size is 2 1/2" less than overall depth.)

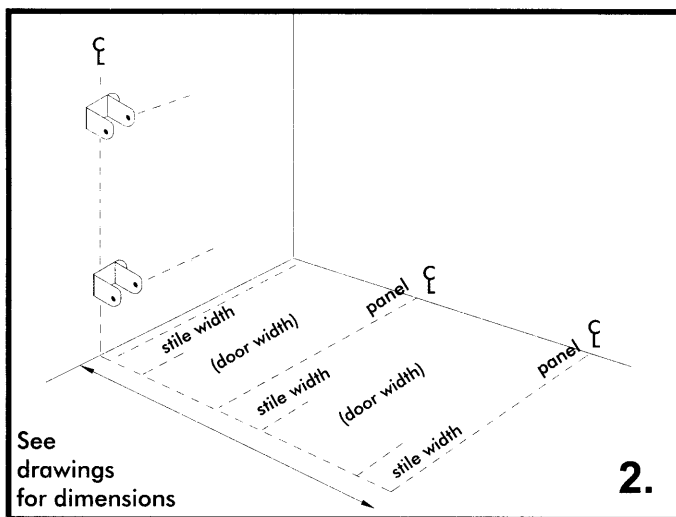

Start at the existing sidewall and mark off the actual width of the individual stile along the stile centerline as determined in Figure 1. Size and location of each stile, as well as the location of hinge holes to mount door hinges, appear on the shop drawings. **Follow shop drawings carefully.** The distance between the existing sidewall the first stile varies and is indicated on the shop drawings.

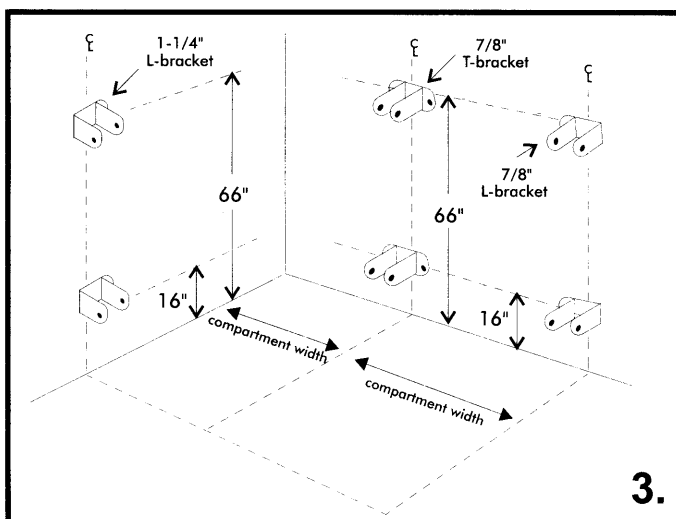

Determine the compartment width. This measurement appears on your shop drawings. Mark compartment width for each compartment and snap chalk line as shown. Place and mark the center of the bottom panel bracket 16" above the floor, and the center of the upper panel bracket 66" above the floor. Wherever possible, place wall anchors in grout lines of tile, mortar joints of cement block, or blocking behind drywall. On back wall, use 7/8" "T" brackets for interior panels and 7/8" "L" brackets for end panels. On sidewalls use 1-1/4" "L" brackets. In cases where 1" thick doors and panels were specified, use 1" brackets supplied. The bracket itself can be used as a template to mark the actual hole locations on the wall. Drill 1/4" holes, insert plastic anchors and mount brackets using 2" hex head fasteners provided in screw pack.

AMPCO INSTALLATION INSTRUCTIONS



TOILET COMPARTMENTS

Floor Mounted and Overhead Braced Construction
High Pressure Laminate, Melamine,
Powder-Coated Baked Enamel,
Solid Surface Veneer, Stainless Steel

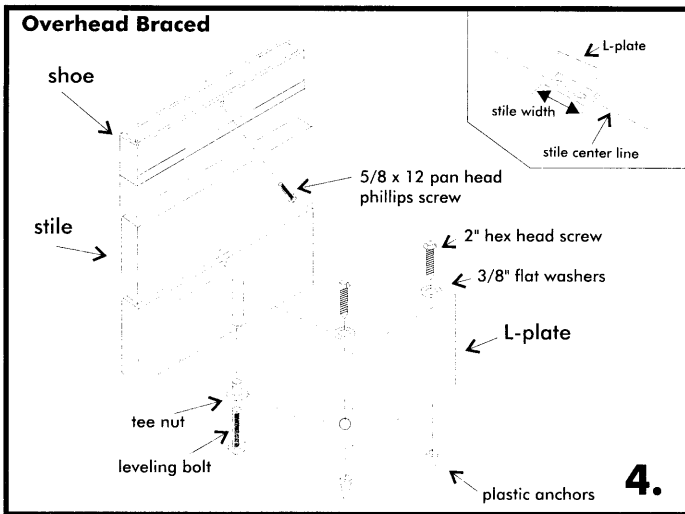

Typically, a bathroom floor is sloped for drainage. Determine which of the L-plates in the room is the highest elevation. This stile must be installed first. All other stiles will be elevated to match its height through adjustment of the leveling bolts inserted in the next step.

Overhead Braced Installations

- A.** Drill a 2" deep by 3/8" diameter hole in the bottom center of the stile. Tap 5/16" tee nut and leveling bolt into the hole. (For Metal and Stainless Steel, leveling bolt is already in stile.) Floor attachment found in HW31 pack.
- B.** Put shoe on stile taking care to locate pre-drilled shoe hole so that it will be on the inside of the stall with the hole on the top. Raise shoe up about 8" and secure with tape temporarily. (Note: For overhead braced and floor mounted construction, the shoe should be on the bottom of the stile.)
- C.** Determine the location of the stile on the floor (as shown in step 2). Using L-plate as a template, mark and drill two 1/4" holes in floor 2" deep. Mount L-plate to the floor using two plastic anchors, 3/8" flat washers and 2" hex head screws located in the screw pack.
- D.** Set stile aside; shoe and stile will be attached to the L-plate in following steps.

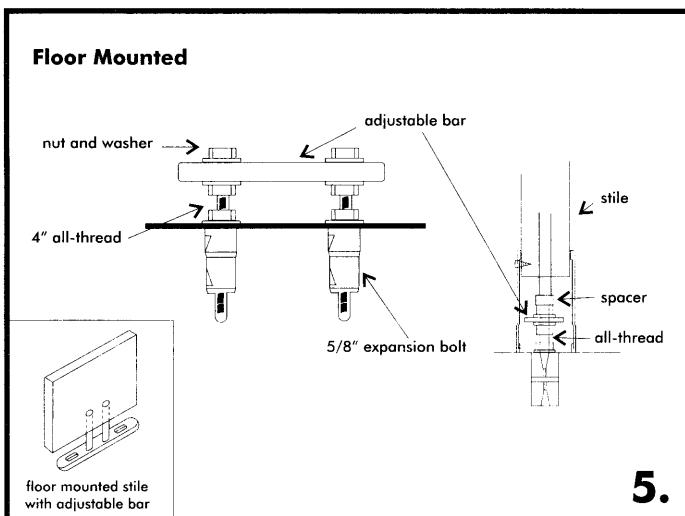

Floor Mounted Installations

- Refer to shop drawing and room layout. Upon location of stile on center of chalk line, drill floor for double rawl plugs 3" deep with 3/4" carbide bit. Location of center will be 3/4" from end of stile. Attach 4" all-thread to rawl plug with washer and nut. Install large washer and nut on rod and turn down almost to first nut. Attachment of adjust bar mechanism will be made onto all-thread bolts. Place washer and nut over top of aluminum adjustable bar and draw tight against bar with box wrench. Height of leveling adjustment will be made with nuts located on the top and bottom of adjustable bar. Do not lock into final position until doors are hung.

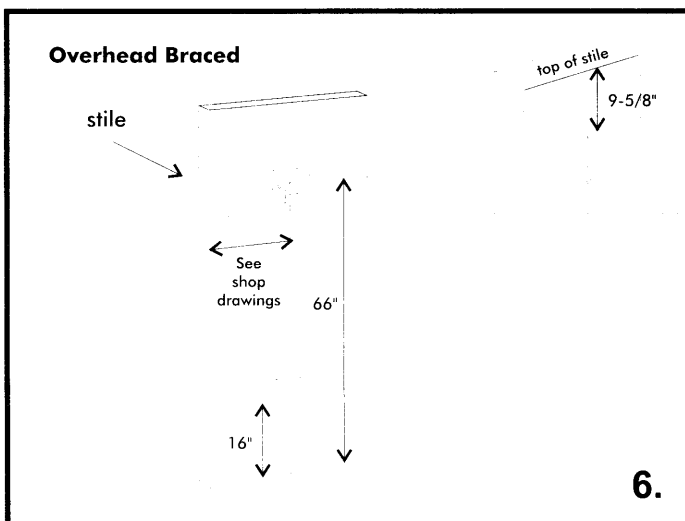

- For Overhead Braced installations**, locate the U-bracket positions on the stiles that receive panels as shown. See shop drawings as the location depends on the size of the stile. (Also note location of hinge holes for mounting door hinges; follow shop drawings carefully). Mark the center for the first U-bracket 16" from the bottom of the stile and the second U-bracket 66" from the bottom of the stile. Mark the hole using the bracket as a template. Drill 1/8" pilot holes into the stile. From the top of the stile measure down 9-5/8" and then mark. This will be the height of the panel inserted in U-brackets (see details).

For Floor Mounted installations (without headrail bracing), mount the top of the panel to the same height as the top of the stile. Mark the hole using the bracket as a template. Drill 1/8" pilot holes into the stile.

Do not drill all the way thru the stile. Fasten the U-brackets to the stile with Phillips head wood screws found in screw pack (HW 21).

AMPCO INSTALLATION INSTRUCTIONS



TOILET COMPARTMENTS

Floor Mounted and Overhead Braced Construction
High Pressure Laminate, Melamine,
Powder-Coated Baked Enamel,
Solid Surface Veneer, Stainless Steel

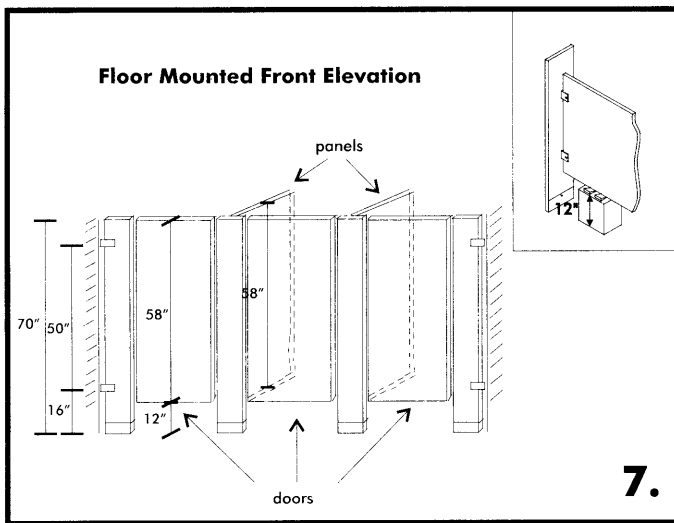

To secure panel to rear wall and stile, set 12" support under panel as shown. Place panel on support and insert into brackets mounted on rear wall. Place stile on L-plate and slide shoe down. Insert panel into U-brackets on stile. Use wedges to raise panel to 9-5/8" mark, or for Floor Mounted installation to the top of the stile. When panel is at proper height, drill thru U-brackets with a 1/4" bit (1/8" bit for Metal and Stainless compartments with 1-way self tapping on each side). Fasten with 3/4" male shoulder screws and 5/8" female barrel nuts. After panel is attached to stile, use wedges to plumb stile, attach panel to "T" brackets on wall using same size fasteners.

Floor Mounted Installation - Starting at wall pilasters or highest point of floor, close door and adjust next pilaster in line for height and equal space at hinge side reveal and lock side reveal. Secure nuts tightly against adjustable bar, locking pilaster into position. Continue across restroom compartment front until all stiles are plumb and level and all door reveals are uniform.

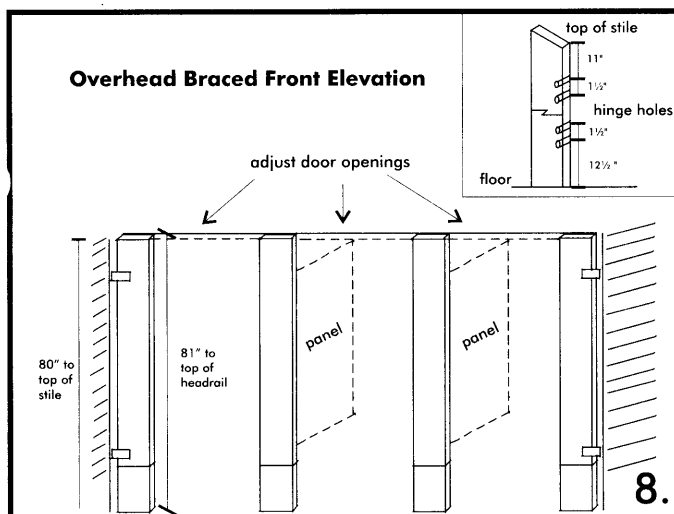

Overhead Braced Installation - Determine location of holes to mount door hinges. In some cases, these holes will be factory-drilled. Prior to attaching remaining stiles to their respective panels, remember to level them to the stile with the highest elevation. Then install remaining panels. Insert wall stiles at this time. If layout is between-wall, first attach the wall stile which has a door hung from it. Place stile out from wall at the distance shown on shop drawings. Plumb this stile and attach to L-brackets with 1-1/16" male shoulder screws and 5/8" female barrel nuts.

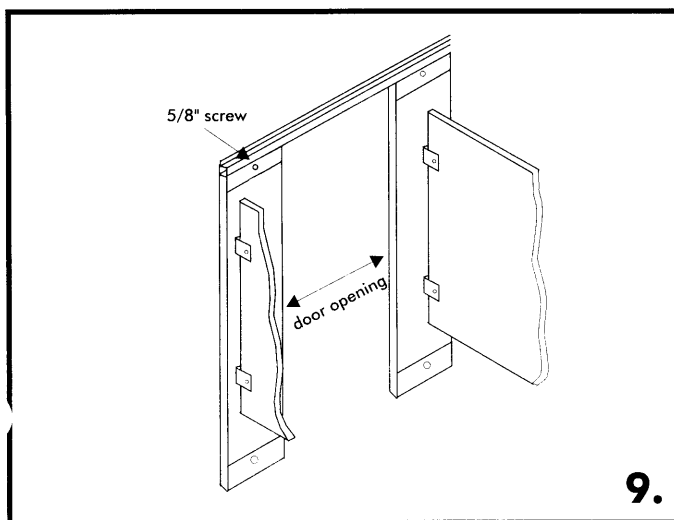

For overhead braced installations, Ampco provides pre-cut length of headrail and return rail for the room sizes shown on shop drawings. We provide the headrail in 5" increments. For example if length required is 72", take a 75" piece and cut to fit your room conditions. Note: Please review all lengths carefully before you cut. We provide only what is needed to minimize waste.

For all door openings, secure using headrail at top and L-plates at bottom of stiles. Rail should be placed on stiles with "antigrip" towards front of stall. Starting from stile attached to wall, create each door opening by adjusting bottom and top of individual stiles. Secure headrail to top of stiles with 5/8" screw. After attaching headrail to top of stiles, drill 1/8" hole thru galvanized "L" plate and screw 5/8" Phillips head into stile (see drawing #4). For floor mounted, please refer to drawing #5.

AMPCO INSTALLATION INSTRUCTIONS



TOILET COMPARTMENTS

Floor Mounted and Overhead Braced Construction
High Pressure Laminate, Melamine,
Powder-Coated Baked Enamel,
Solid Surface Veneer, Stainless Steel

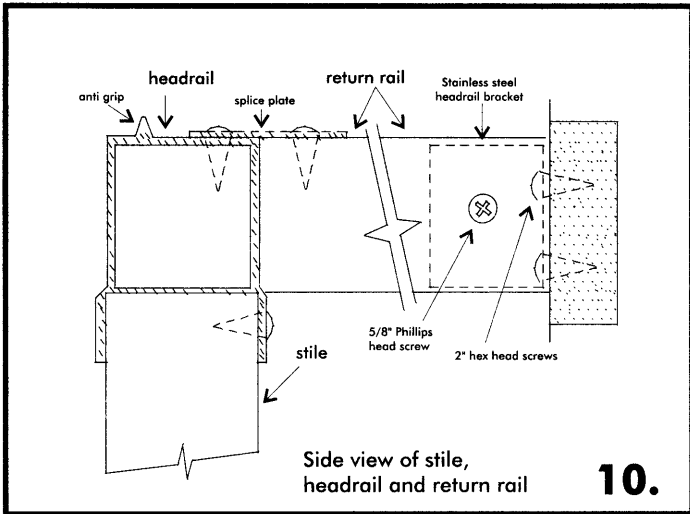

Return rail placement is shown on shop drawings. It is attached to headrail with a splice plate and attached at rear wall of the stall with a rail bracket. After sliding return rail over the bracket, drill an 1/8" pilot hole thru the return rail and bracket. Secure with 5/8" phillips head screw.

For Metal and Stainless Steel, return rail is attached to headrail with a splice plate and attached at rear wall of the stall with a saddle. After sliding return rail into the saddle, drill a 1/4" hole thru the return rail and secure with thru bolt.

An end cap is provided for a finished look. Tap into exposed end of headrail.

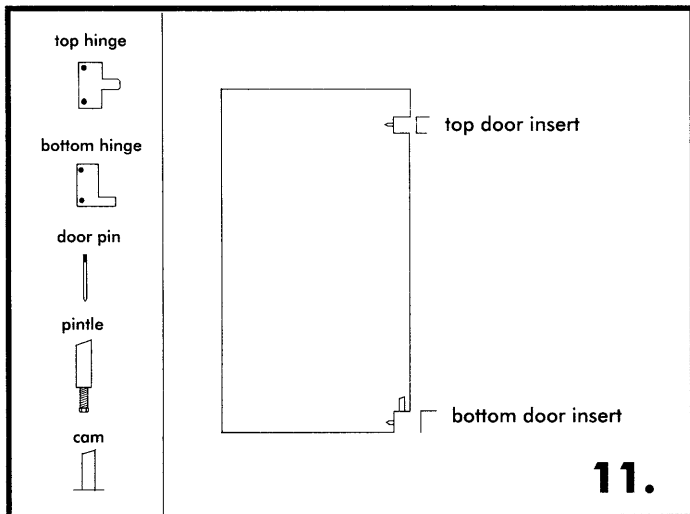
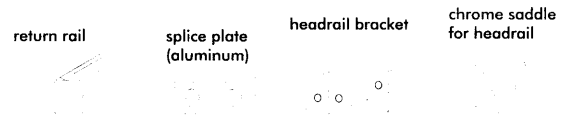

For Overhead Braced and Floor Mounted, insert the top door insert into the cutout in the door. Fasten the flat head screw provided in door pack. Place bottom insert at bottom of door and tap cam in hole. Fasten with screw provided. Attach hinges to stiles top and bottom using male 1-1/16" shoulders and female 5/8" barrels. Set bottom of door on pintle and **gently** hammer down door pin into hole on top of door. Pin knurl must be on top of door.

For Metal and Stainless Steel, place bottom insert at bottom of door and tap cam in hole. Attach hinges to stile, top and bottom, using male 1 1/16 shoulders and female 5/8 barrels. Set bottom of door on pintle and screw door pin into hole on top of door.

Adjustment for door closure is made using gravity pintle cam feature on bottom hinge. A rut at the base of the pintle is tightened when door is in proper position. Attach latches, coat hooks, and bumpers.

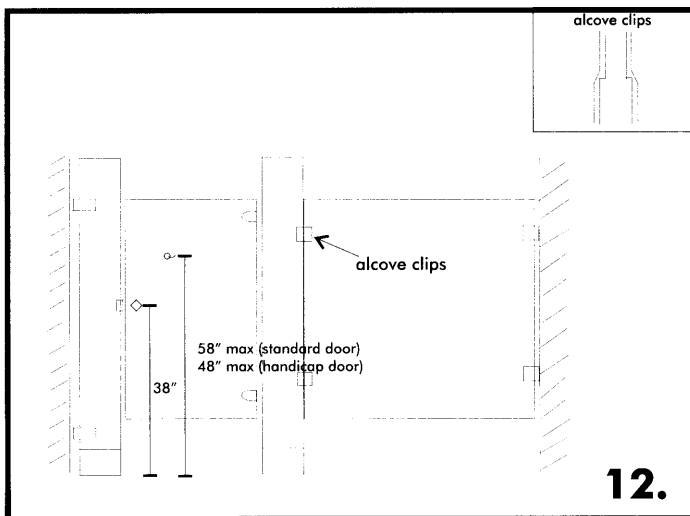

In a layout where a stile and a panel are in-line, we provide special "reducer" hardware called alcove clips. This will allow for the relative thickness between panels and stiles.

See drawing for mounting locations for coat hook, slide latch and keeper.

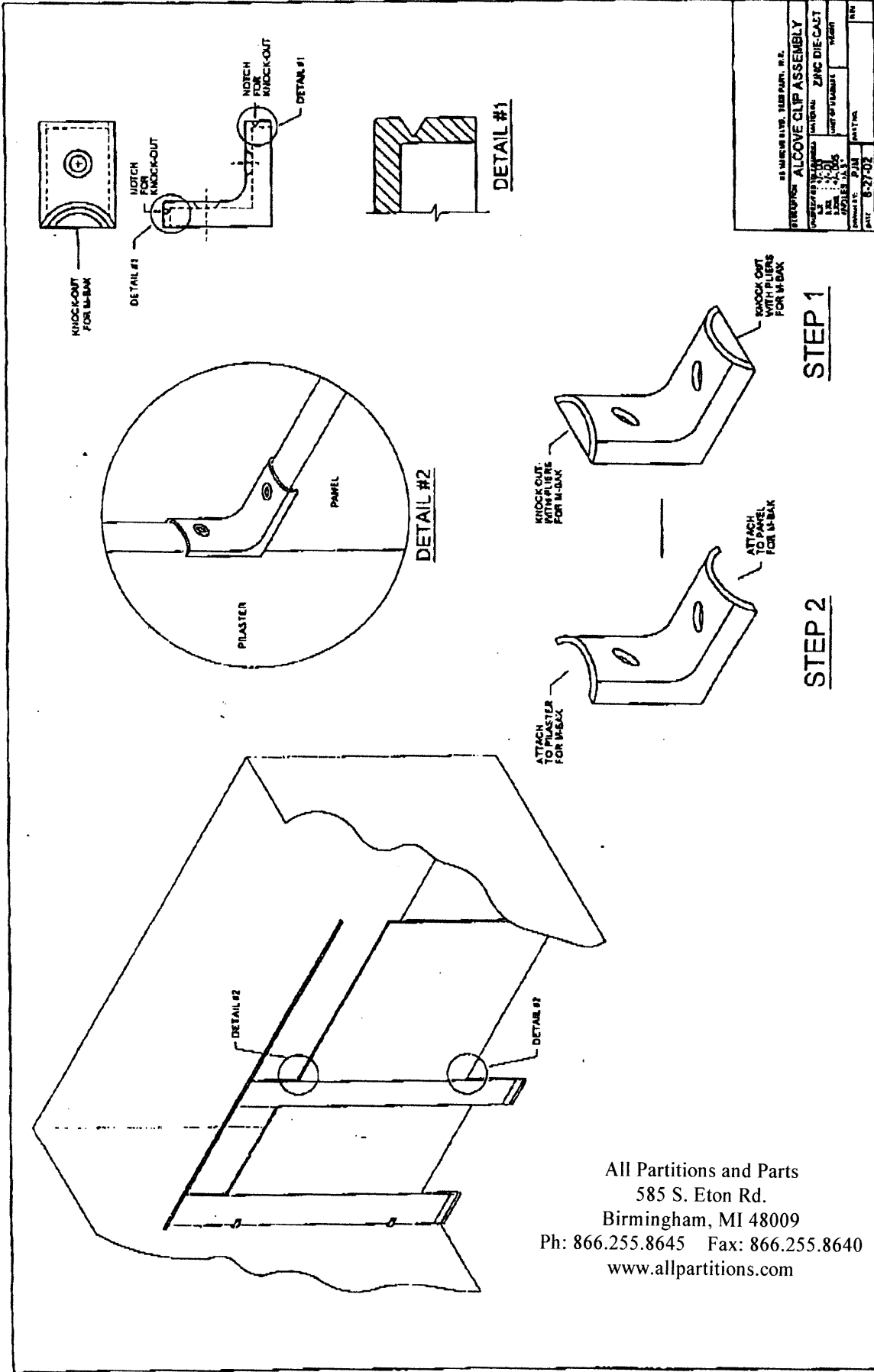

35 MICHIGAN BLVD. STEEL PART. N.Z.		PART NO.	
DESCRIPTION: ALCOVE CLIP ASSEMBLY		PART NO.	
QUANTITY: 1000	MATERIAL: ZINC DIE-CAST	DATE: 8-27-02	REV.
BY: J.M.	DATE: 8-27-02	BY: J.M.	DATE: 8-27-02
APPROVED: J.M.	DATE: 8-27-02	APPROVED: J.M.	DATE: 8-27-02

All Partitions and Parts
 585 S. Eton Rd.
 Birmingham, MI 48009
 Ph: 866.255.8645 Fax: 866.255.8640
 www.allpartitions.com