



Owner's Manual

***1802, 1803, 1808, 1810
Telephone Entry Systems***

DoorKing, Inc.
120 Glasgow Avenue
Inglewood, California 90301
U.S.A.

Phone: 310-645-0023

Fax: 310-641-1586

www.doorking.com

Use this manual with the following models only.

All 1802, 1803, 1808 and 1810 Telephone Entry Systems with circuit board 1862-010, Rev A or higher.

DoorKing, Inc. reserves the right to make changes in the products described in this manual without notice and without obligation of DoorKing, Inc. to notify any persons of any such revisions or changes. Additionally, DoorKing, Inc. makes no representations or warranties with respect to this manual. This manual is copyrighted, all rights reserved. No portion of this manual may be copied, reproduced, translated, or reduced to any electronic medium without prior written consent from DoorKing, Inc.

NOTE: The log tables and resident instruction sheet (pages 50-53) may be copied as needed.

QUICK START

- 1 Mount the Telephone Entry System. **If the unit is being used to provide access through an automated vehicular gate, the unit must be mounted at least 10-feet away from the gate.**
See pages 11-19.

- 2 Connect 16 VAC power to terminals 13-14. Connect a dedicated touch-tone loop-start phone line to terminals 1-2. Connect ground wire to terminal 3.
See pages 25-26.

- 3 Connect device(s) to be activated (gate operator, door strikes, etc.) to relay terminals as required.
See pages 25-26.

- 4 Program a MASTER CODE (Section 3.1.1) - Factory Default is 9999
 1. Open the cabinet and turn the Master Code switch ON.
 2. Enter a four-digit Master Code on the keypad and then press *.
 3. Turn the Master Code switch OFF.

- 5 Set the DIRECTORY CODE Length (Section 3.2.1) - Factory Default is 3-digits
 1. Press *20 and enter the Master Code.
 2. Enter the desired Directory Code length (1-2-3 or 4) then press *.

- 6 Program Phone Numbers (Section 3.2.2)
 1. Press *01 and enter Master Code.
 2. Enter a Directory Code then press *.
 3. Enter a 7-digit Phone Number then press *.
 4. Repeat 2-3 to enter more numbers.
 5. Press 0# TOGETHER when finished.

TABLE OF CONTENTS

Preface

Important Notices	8
Important Information.....	9
Features	10

Section 1 – Installation

1.1	Installation Guidelines – All Systems	11
1.1.1	Surface 1803 and 1810 Mount Units	12
1.1.2	Surface Mount 1803 and 1810 Units with Recess Box	13
1.1.3	Flush Mount 1803 and 1810 Units.....	14
1.1.4	Flush Mount Rough-in Box (1803 and 1810 only).....	15
1.1.5	Flush Mount Trim Ring (1803 and 1810 only).....	16
1.1.6	Flush Mount Surface Mounting Kit (1803 and 1810 only)	17
1.1.7	1802 Surface Mount.....	18
1.1.8	1808 Surface Mount.....	19
1.2	Memory Chip Installation.....	20
1.3	Postal Lock Installation	21

Section 2 – Wiring & Adjustments

	General Information.....	23
	Circuit Board Adjustment Locations	24
	Wiring Diagram.....	25
2.1	Main Terminal Description	26
2.2	Circuit Board Adjustments	
2.2.1	Speaker Volume	27
2.2.2	Feedback	27
2.2.3	Click Sensitivity	27
2.2.4	Display Contrast (1802, 1803, 1810 only).....	27
2.2.5	Master Code Switch	28
2.2.6	Ring Pin	28
2.2.7	Handset / Hands Free	28

Section 3 – Programming

	General Information.....	29
3.1	General Programming	
3.1.1	Master Code	30
3.1.2	Single or Multiple Systems.....	30
3.1.3	Relay Strike Time.....	30
3.1.4	Talk Time	31
3.1.5	Tone Open Numbers.....	31
3.1.6	Postal Switch	32
3.1.7	Touch-tone / Rotary-dial.....	32
3.1.8	Number of Rings to Answer	32
3.1.9	Keypad Function	33
3.1.10	Star (*) Key Function.....	33

3.2	Phone Number Programming	
3.2.1	Directory Code Length.....	34
3.2.2	7-Digit Phone Numbers	34
3.2.3	Area Codes	35
3.2.4	Phone Numbers with Area Code Reference	35
3.2.5	Deleting Individual Phone Numbers	35
3.2.6	Delete All Phone Numbers	36
3.2.7	Display / Delete Phone Numbers.....	36
3.2.8	Display Phone Numbers with Known Directory Code	36
3.3	Entry Code Programming	
3.3.1	Four-Digit Entry Code Programming	37
3.3.2	Delete Individual Four-Digit Entry Codes.....	37
3.3.3	Delete All Four-Digit Entry Codes.....	37
3.3.4	Four-Digit Entry Code Divide Number	37
3.3.5	Five-Digit Entry Code Programming	38
3.3.6	Delete Individual Five-Digit Entry Codes	38
3.3.7	Delete All Five-Digit Entry Codes	38
3.3.8	Five-Digit Entry Code Divide Number	38
3.4	Time Functions Programming	
3.4.1	Time Clock Programming.....	39
3.4.2	Automatic Relay Activation Time Zones.....	39
3.4.3	Four-Digit Entry Code Time Zone.....	40
3.4.4	Five-Digit Entry Code Time Zone	40
3.4.5	Flash Entry Codes.....	41

Section 4 – Operating Instructions

4.1	General Instructions	
4.1.1	Guest Instructions	43
4.1.2	Responding to a Guest Call.....	43
4.1.3	Using Entry Codes	43
4.2	System Administrator	
4.2.1	Remote Programming	44
4.2.2	Remote Relay Activation	44
4.2.3	Relay Check.....	44
4.2.4	Entry Code Time Zone Enable / Disable.....	45
4.2.5	Auto Relay Activation Time Zone Enable / Disable.....	45
4.3	Miscellaneous Operating Instructions	
4.3.1	Switch Input Operation	46
4.3.2	Talk Time	46
4.3.3	Line Sharing.....	46
4.3.4	Connection to a PBX.....	47
4.3.5	10-digit Dialing	47

Section 5 – Maintenance and Trouble Shooting

5.1	Replacement Parts	49
5.2	Trouble Shooting.....	49
5.3	Accessories	51
5.4	Log Tables	52
	Resident Instruction Sheet.....	55

IMPORTANT NOTICE

FCC - UNITED STATES

This equipment has been tested and found to comply with the limits for a class A digital device, pursuant to Part 15 of the FCC Rules and Regulations. These limits are designed to provide reasonable protection against harmful interference when the equipment is operated in a commercial environment. This equipment generates, uses, and can radiate radio frequency energy and, if not installed and used in accordance with the instruction manual, may cause harmful interference to radio communications. Operation of this equipment in a residential area is likely to cause harmful interference in which case the user will be required to correct the interference at his own expense.

FCC Registration Number: **DUF6VT-12874-OT-T**

DOC - CANADA

The Canadian Department of Communications label identifies certified equipment. This certification means that the equipment meets certain telecommunications network protective, operational, and safety requirements. The Department does not guarantee the equipment will operate to the users satisfaction.

Before installing this equipment, users should ensure that it is permissible to be connected to the facilities of the local telecommunications company. The equipment must also be installed using an acceptable means of connection. The customer should be aware that compliance with the above conditions may not prevent degradation of service in some situations.

Repairs to certified equipment should be made by an authorized Canadian maintenance facility designated by the supplier. Any repairs or alterations made by the user to this equipment, or equipment malfunctions, may give the telecommunications company cause to request the user to disconnect the equipment.

Users should ensure, for their own protection, that the electrical ground connections of the power utility, telephone lines, and internal metallic water pipe system, if present, are connected together. This precaution may be particularly important in rural areas.

CAUTION: Users should not attempt to make such connections themselves, but should contact the appropriate electric inspection authority, or electrician, as appropriate.

DOC Registration Number: **1736 4528 A**

Notice:

The Load Number (LN) assigned to each terminal device denotes the percentage of the total load to be connected to a telephone loop which is used by the device, to prevent overloading. The termination on a loop may consist of any combination of devices subject only to the requirement that the sum of the load numbers of all the devices does not exceed 100.

Notice:

DoorKing does not provide a power transformer on units sold into Canada. Use only transformers that are CSA listed to power the telephone entry system. 1802, 1803, 1808, 1810, 1814, 1815, 1818 and all "P" series systems require a 16.5-volt, 20 VA transformer. The models 1816 and 1817 require a 16.5-volt, 40 VA transformer. The model 1812 requires a 24-volt, 20 VA transformer.

Listing:

This product has been tested to and found to be in compliance with the U.L 294 Safety Standard by Intertek Testing Services NA Inc. (a Nationally Recognized Testing Laboratory) and is ETL listed.

IMPORTANT INFORMATION

- Prior to beginning the installation of the telephone entry system, we suggest that you become familiar with the instructions, illustrations, and wiring guidelines in this manual. This will help insure that your installation is performed in an efficient and professional manner.
- The proper installation of the telephone entry panel is an extremely important and integral part of the overall access control system. Check all local building ordinances and building codes prior to installing this system. Be sure your installation is in compliance with local codes.
- When used to control a door or pedestrian gate, try to locate the telephone entry system as near as possible to the entry point. The unit should be mounted on a rigid wall to prevent excessive shock and vibration from closing doors or gates. Continuous vibration and shock from slamming doors or spring-loaded pedestrian gates will damage the circuit board. **Under no circumstances should the unit be mounted directly to a moving door or gate.**
- **ADA mounting requirements for door control.** The mounting of the unit shall be in such a way that the LCD display is positioned so that it is readily visible to and usable by a person sitting in a wheelchair with an approximate eye level of 45 inches and shall comply with the following requirements:
 1. If mounted vertically or tipped no more than 30 degrees away from the viewer, the center line of the LCD shall be located a maximum of 52 inches above grade.
 2. If the clear floor space allows only forward approach to the system, the maximum high forward reach allowed is 48 inches above grade to the top of the keypad.
 3. If the high forward reach to the system is over an obstruction of greater than 20 inches but less than 25 inches, the maximum high forward reach allowed is 44 inches above grade to the top of the keypad.
 4. If the clear floor space allows parallel approach by a person in a wheelchair, the maximum high side reach shall be 54 inches above grade to the top of the keypad.
 5. If the high side reach is over an obstruction of 24 inches or less, the maximum high side reach allowed is 46 inches above grade to the top of the keypad.
- **When used to control a vehicular gate with an automatic gate operator, the telephone entry system must be mounted a minimum of ten (10) feet away from the gate and gate operator, or in such a way that a person cannot operate the entry system and/or touch the gate or gate operator at the same time.**
- Be sure that the system is installed so that it is not directly in the traffic lane. Goose neck mounting post and kiosks work well for these type systems. When planning where to locate the system, take into consideration traffic lane layouts, turn around lanes for rejected access, conduit runs, power availability, etc.
- Environmental factors must also be taken into account. Surface mount units are designed for direct outdoor installations, however it is preferable to protect them from direct exposure to driven rain or snow whenever possible. Flush mount and wall mount units must be protected from direct exposure to the elements. Be sure that ample lighting is provided so that guest can read both the directory and the operating instructions at night.
- This telephone entry system contains a number of static sensitive components that can be damaged or destroyed by static discharges during installation or use. Discharge any static prior to removing the circuit board from the lobby panel by touching a proper ground device.
- **Instruct the end user to read and follow these instructions. Instruct the end user to never let children play with or operate any access control device. This Owner's Manual is the property of the end user and must be left with them when installation is complete.**

FEATURES

- Can provide service for up to 1000 residents.
- System can be programmed from the front keypad or remotely using a touch-tone telephone.
- System keypad will emit DTMF tones after a call is answered allowing the system to be used with auto-attendants, answering machines, etc.
- Directory codes can be set from 1 to 4 digits in length and can be randomly assigned.
- 10 programmable area codes allow the system to be used in areas requiring 10 and 11-digit dialing.
- Two internal relays allow the system to control a main entry point plus an additional entry point.
- Built in time clock provides hold open time zones, entry code time zones and “Flash” entry codes.
- 5-digit entry codes available for special needs.
- Programmable switch inputs can be set to activate a relay or to dial a preprogrammed phone number.

SECTION 1 - INSTALLATION

Order your telephone line at least two weeks prior to the planned installation date. This will assure that a phone line is available when the unit is installed. The telephone company will require the following information from you:

Type:	Touch Tone, Loop Start
Ringer Equivalence:	0.0 A
Jack Type:	RJ11C
FCC Registration (US):	DUF6VT-12874-OT-T
DOC (Canada):	1736 4528 A
Electrical Listing:	Complies with U.L. 294 - ETL Listed

CALLER ID: You may want to consider ordering caller ID blocking from the telephone company for the entry system phone line. Without caller ID blocking, tenants with the proper phone equipment will be able to identify the telephone number that the entry system is installed on. This may or may not be desirable.

1.1 INSTALLATION GUIDELINES – ALL SYSTEMS

1. Open the cabinet of the telephone entry system and disconnect the keypad ribbon cable from the main circuit board.
2. Remove the 6-32 x 1/2 round head screws from the upper corners of the circuit board.
3. Remove the circuit board by gently pulling it out of the main terminal edge connector. **CAUTION** - the circuit board contains static sensitive components. Discharge any static electricity from your hands by touching a proper ground device before removing the circuit board. Place the circuit board where it will not be damaged.
4. Mount the cabinet of the telephone entry system. Be sure that mounting screws do not protrude into the cabinet where they could cause a short on the back of the circuit board. Make any necessary conduit connections.
5. Route wiring into the cabinet. Do not apply any power at this time.
6. Clean out the cabinet. Be sure that all dirt, metal and/or wood debris is removed from the cabinet and that the terminal strip edge connector is clean and free of any loose particles.
7. Re-install the circuit board into the cabinet by gently pushing the circuit board terminals into the edge connector. **CAUTION** - the circuit board contains static sensitive components. Discharge any static electricity from your hands by touching a proper ground device before removing the circuit board.
8. Secure the circuit board to the cabinet using the screws removed in step 2.
9. Plug the keypad ribbon cable into the circuit board. The cable points down.



WARNING! If this entry system is used to control a vehicular gate with an automatic gate operator, the entry system must be mounted a minimum of ten (10) feet away from the gate and gate operator, or in such a way that a person cannot operate the entry system and touch the gate or gate operator at the same time.

1.1.1 Surface Mount 1803 and 1810 Units

Surface mount units can be mounted directly to a wall or pilaster, or can be post mounted using a DoorKing Architectural Style heavy-duty mounting post (p/n 1200-037 and 1200-038). Be sure the unit is mounted securely and is not subject to vibration from closing doors or gates.



WARNING! If this entry system is used to control a vehicular gate with an automatic gate operator, the entry system must be mounted a minimum of ten (10) feet away from the gate and gate operator, or in such a way that a person cannot operate the entry system and touch the gate or gate operator at the same time.

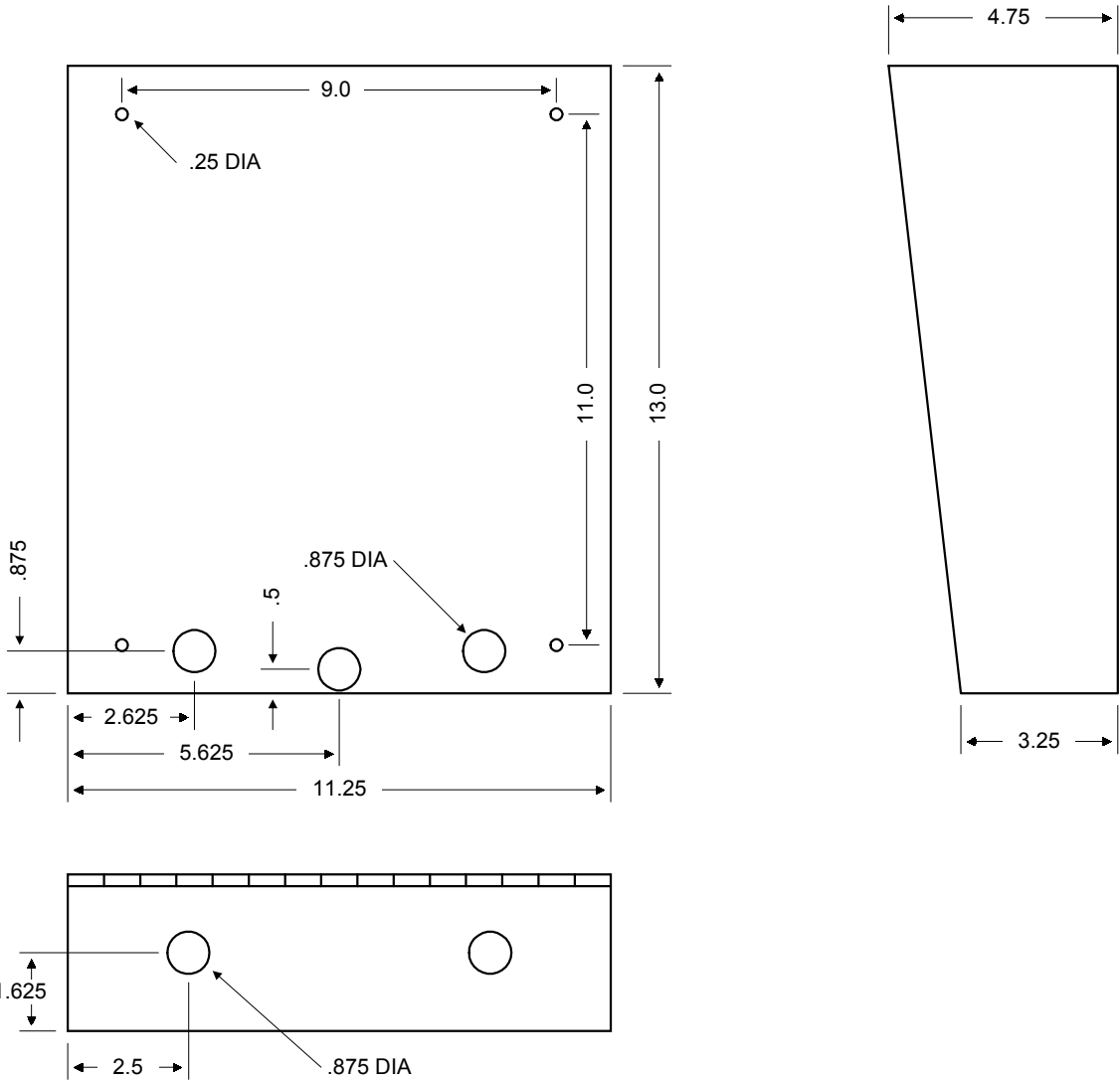

1.1.2 Surface Mount 1803 and 1810 Units with Recess Box

Surface mount units can be semi-flush mounted into a wall or pilaster by using the optional recess-mounting box (p/n 1803-150). Be sure the unit is mounted securely and is not subject to vibration from closing doors or gates.



WARNING! If this entry system is used to control a vehicular gate with an automatic gate operator, the entry system must be mounted a minimum of ten (10) feet away from the gate and gate operator, or in such a way that a person cannot operate the entry system and touch the gate or gate operator at the same time.

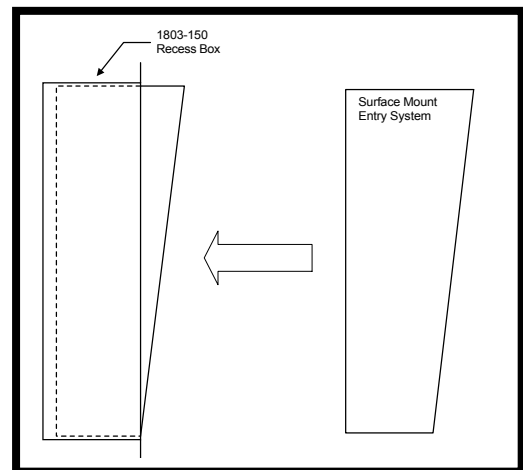
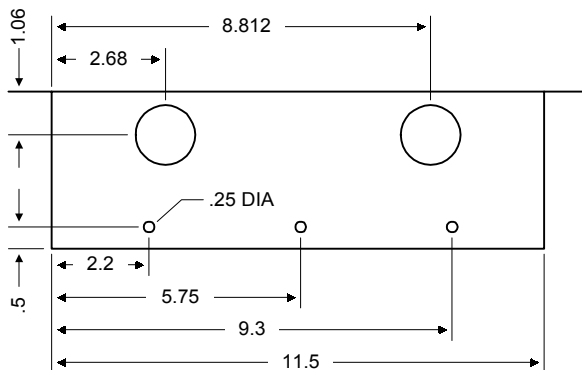
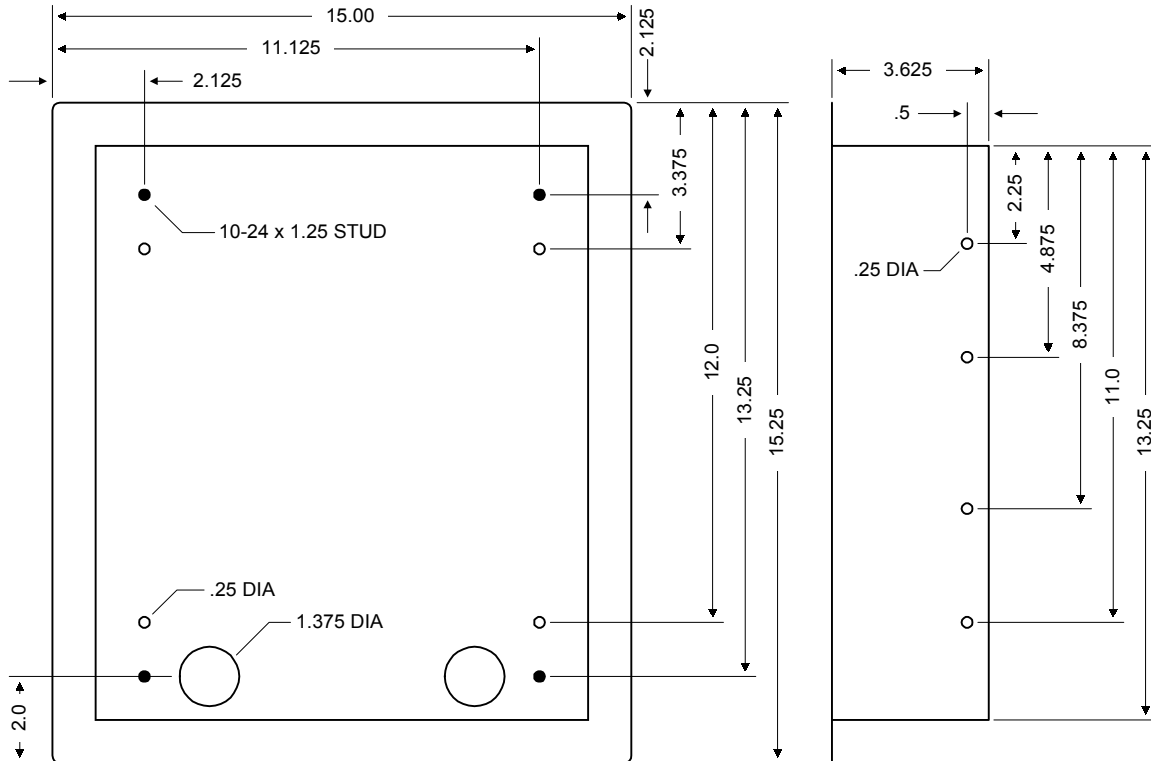

1.1.3 Flush Mount 1803 and 1810 Units

Flush mount units are installed into a wall with flush mount kits 1814-065 (stainless) or 1814-066 (gold). Flush mount kits are not included with the entry system. Flush mount units are not designed for direct exposure to the weather. Be sure the unit is mounted securely and is not subject to vibration from closing doors or gates.



WARNING! If this entry system is used to control a vehicular gate with an automatic gate operator, the entry system must be mounted a minimum of ten (10) feet away from the gate and gate operator, or in such a way that a person cannot operate the entry system and touch the gate or gate operator at the same time.

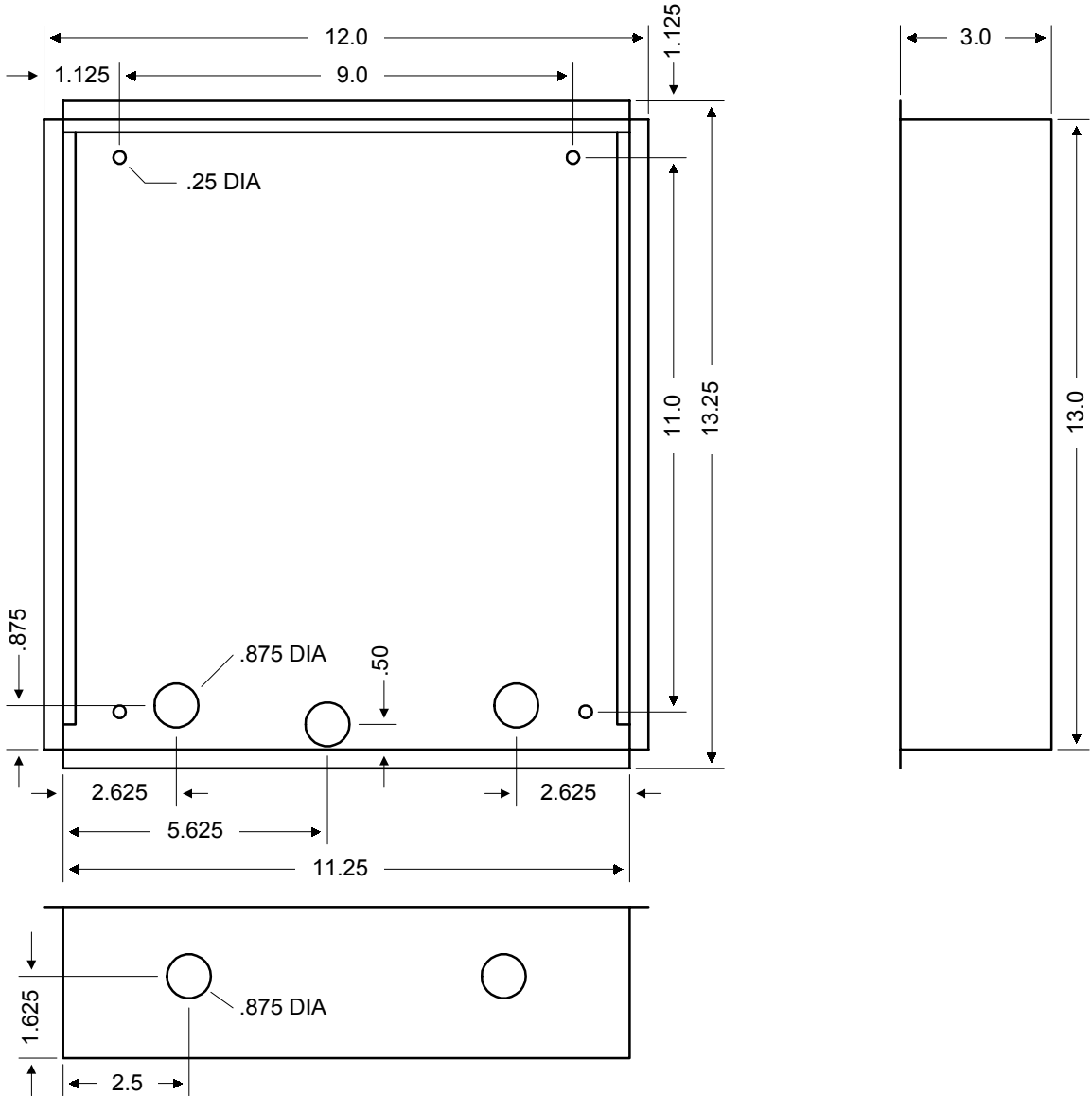

1.1.4 Flush Mount Rough-in Box (applies to 1803 and 1810 only)

The flush mount installation kit has two parts; the rough-in box and the trim ring. The rough-in box is installed first.

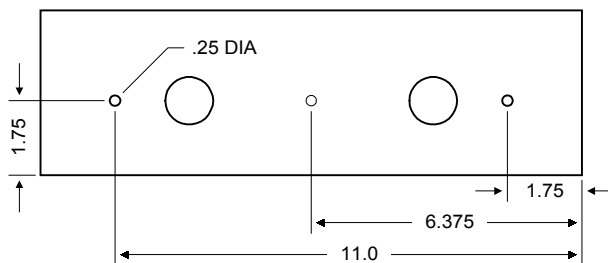
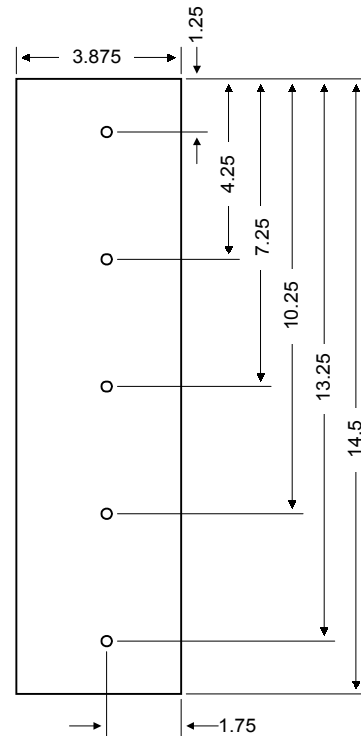
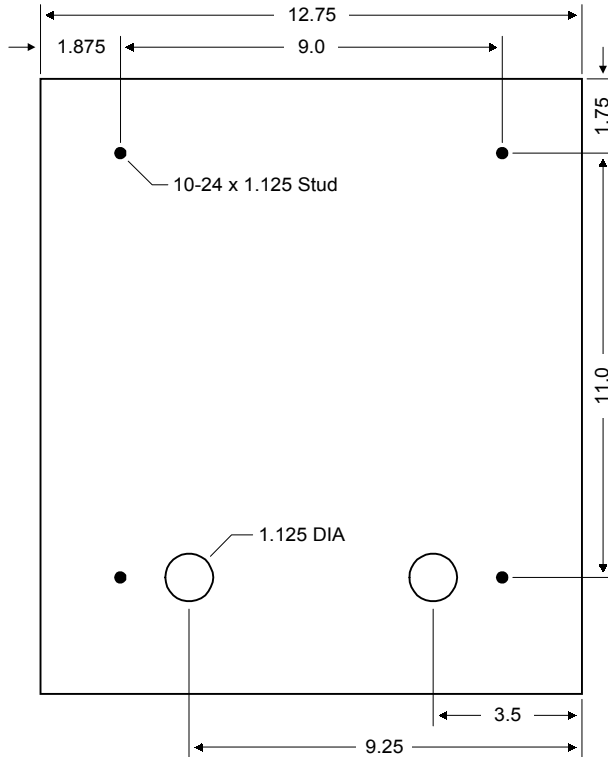

1.1.5 Flush Mount Trim Ring (use with 1803 and 1810 units only)

Flush mount units can be mounted by using the 1814-065 (stainless) or 1814-066 (gold) mounting kit. Flush mounting kits are not included with the unit. Flush mount units are not designed for direct exposure to the weather. Be sure the unit is mounted securely and is not subject to vibration from closing doors or gates.



WARNING! If this entry system is used to control a vehicular gate with an automatic gate operator, the entry system must be mounted a minimum of ten (10) feet away from the gate and gate operator, or in such a way that a person cannot operate the entry system and touch the gate or gate operator at the same time.

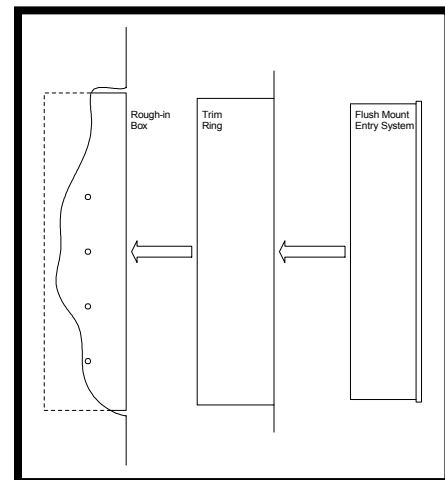
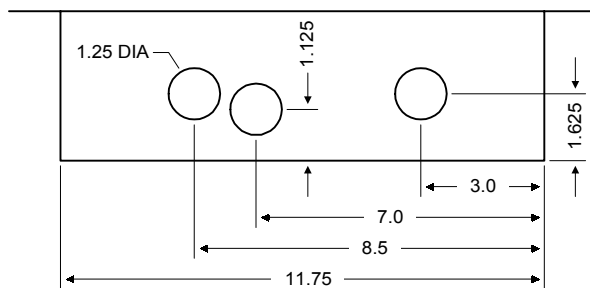
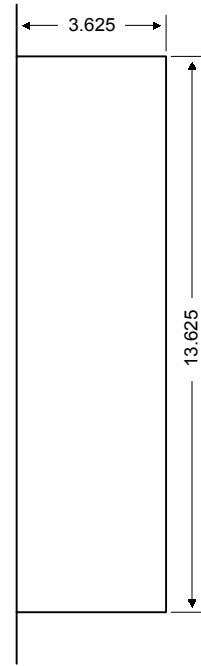
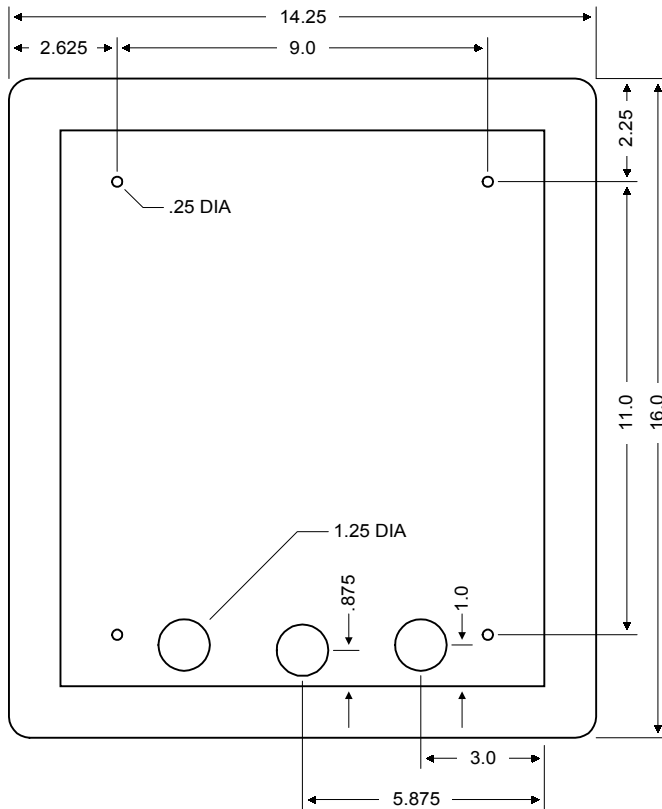

1.1.6 Flush Mount Surface Mounting Kit (use with 1803 and 1810 units only)

Flush mount units can be surface mounted by using the optional 1814-152 surface mount trim ring. Flush mount units are not designed for direct exposure to the weather. Be sure that the unit is securely mounted and is not subject to vibration from closing doors or gates.



WARNING! If this entry system is used to control a vehicular gate with an automatic gate operator, the entry system must be mounted a minimum of ten (10) feet away from the gate and gate operator, or in such a way that a person cannot operate the entry system and touch the gate or gate operator at the same time.

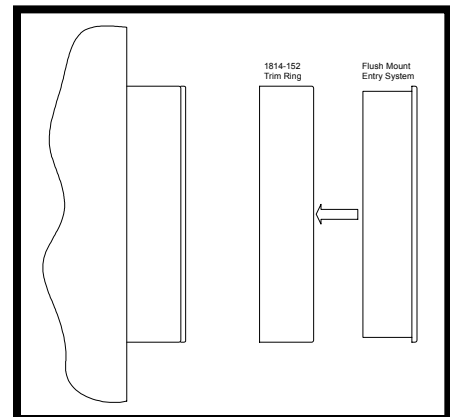
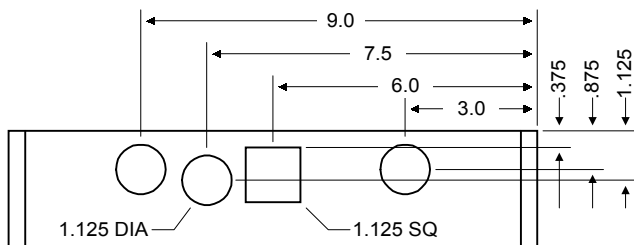
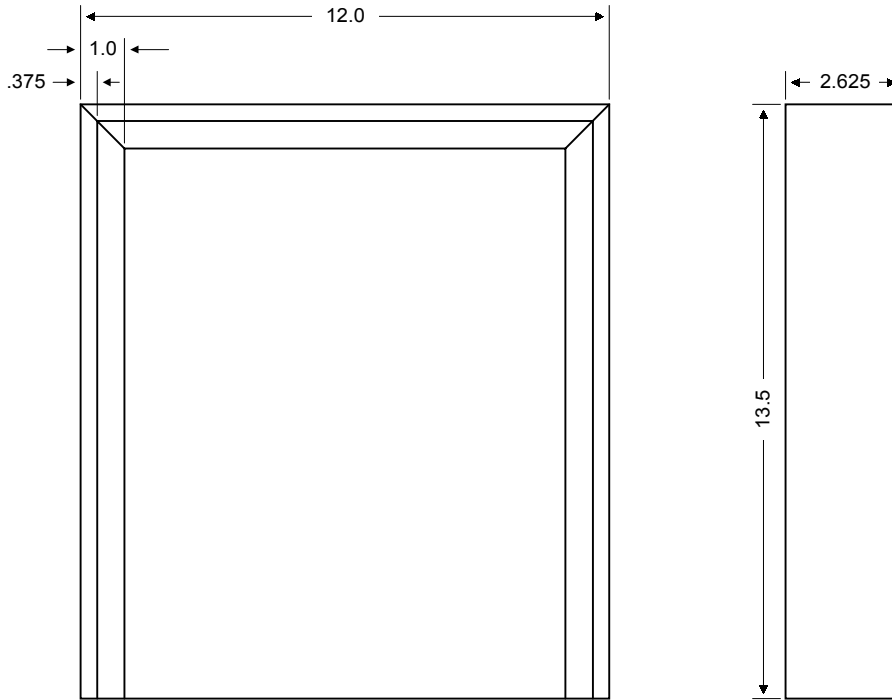

1.1.7 1802 Surface Mount Only

Surface mount units can be mounted directly to a wall or pilaster, or can be post mounted using a DoorKing mounting post (p/n 1200-045 and 1200-046). Be sure the unit is mounted securely and is not subject to vibration from closing doors or gates.



WARNING! If this entry system is used to control a vehicular gate with an automatic gate operator, the entry system must be mounted a minimum of ten (10) feet away from the gate and gate operator, or in such a way that a person cannot operate the entry system and touch the gate or gate operator at the same time.

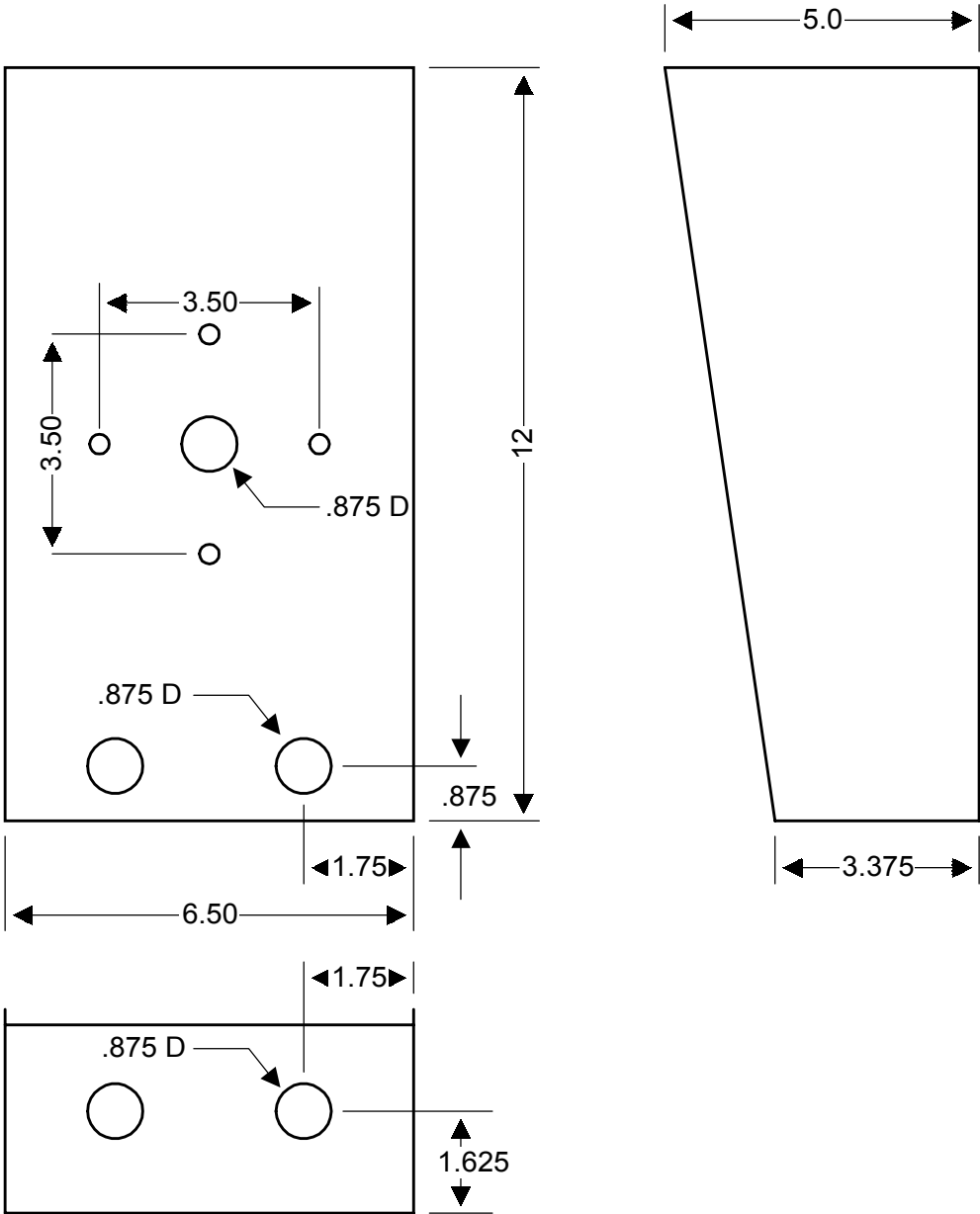

1.1.8 1808 Surface Mount Only

Surface mount units can be mounted directly to a wall or pilaster, or can be post mounted using a DoorKing mounting post (p/n 1200-045 and 1200-046). Be sure the unit is mounted securely and is not subject to vibration from closing doors or gates.



WARNING! If this entry system is used to control a vehicular gate with an automatic gate operator, the entry system must be mounted a minimum of ten (10) feet away from the gate and gate operator, or in such a way that a person cannot operate the entry system and touch the gate or gate operator at the same time.

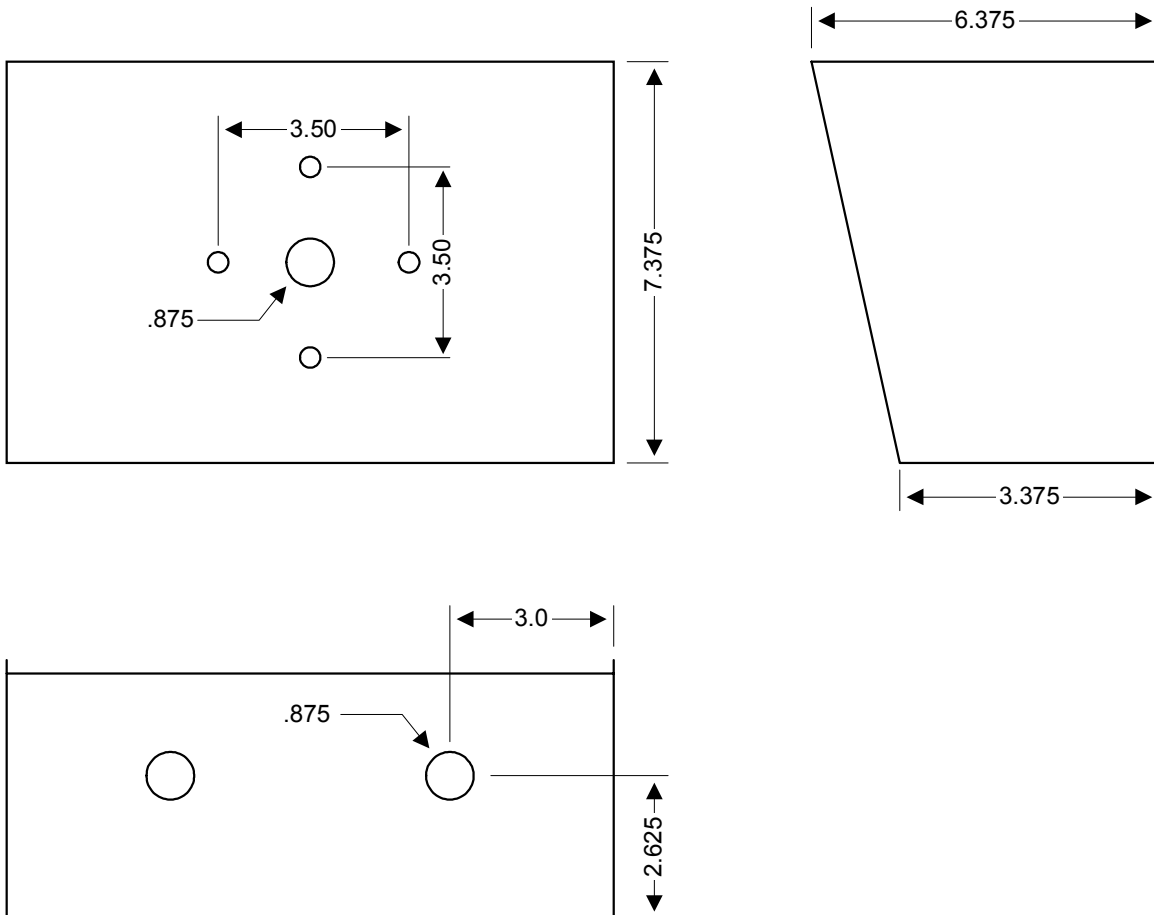

1.2 MEMORY CHIP INSTALLATION

The telephone entry system is shipped with a memory chip packaged in a separate box inside the shipping container. The memory chip must be installed for the telephone entry system to operate.

CAUTION!! Do not install the memory chip with power to the telephone entry system turned on. Attempting to install the memory chip with power on will irrevocably damage the chip.

CAUTION!! The memory chip is a static sensitive component. Discharge any static electricity from your hands by touching a proper ground device before removing the control board. Handle the memory chip with care.

1. The large memory chip socket is colored blue and is located on the right hand side of the circuit board. Be sure that the handle is in the un-locked position (towards the left). Be sure that power to the telephone entry system is off.
2. Carefully insert the memory chip into the socket. The small half circular indentation on the chip must be at the top. **CAUTION:** Installing the memory chip upside down will cause permanent damage to the chip. Be sure that the memory chip is seated correctly in the socket.
3. Move the lever on the chip socket to the locked position (towards the right).

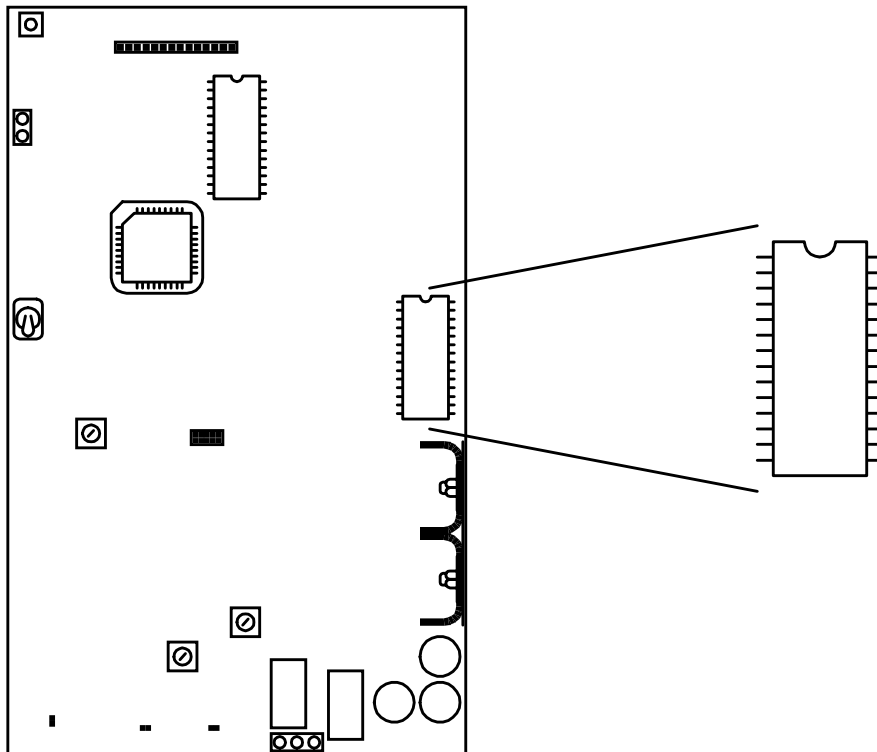

1.3 POSTAL LOCK INSTALLATION

At some locations, such as gated communities, it will be necessary to provide access to the mail carrier so that they can deliver the mail. Mail carrier access will be provided by the installation of an Arrow Postal Lock. This is the same lock that the Post Office uses for gang mailboxes. These locks are not available to the public. The installer or the building owner/manager will have to call the Post Office and arrange for the installation of this lock into the telephone entry system. The 1802, 1803 and 1810 units are all pre-wired to accept the installation of the postal lock.

The 1808 unit cannot accept the postal lock. If you are using the 1808 and need postal service access, use the DoorKing Postal Lock Box (P/N 1402-080).

Prior to installation of the postal lock, be sure power to the telephone entry system is turned off.

1. Remove the hole plug on the faceplate of the telephone entry system.
2. Cut the wire tie wrapped around the micro switch next to the postal lock access hole.
3. Remove the two hex nuts from the postal lock-mounting studs. Mount the postal lock on the two studs and secure with the hex nuts.

When the lock is installed, check to be sure that the pawl of the lock, in its extended position, is depressing the micro switch (the micro switch is wired normally closed). When the mail carrier inserts his key and turns the postal lock, the pawl is withdrawn and the micro switch will activate the relay that has been programmed for this function for the programmed strike time.

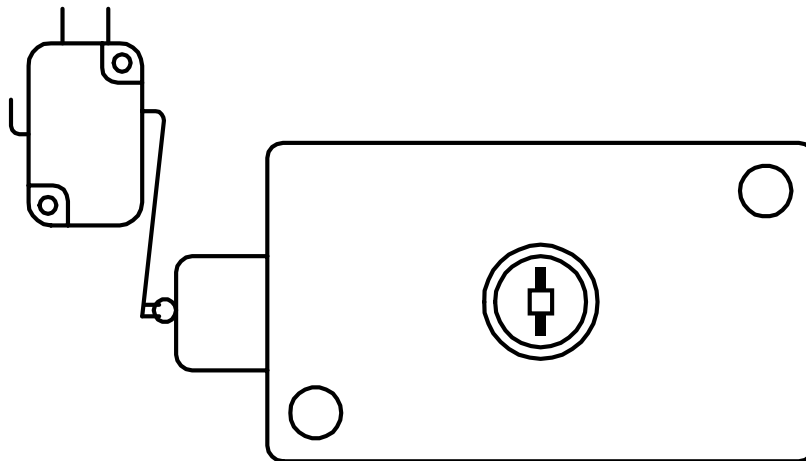

SECTION 2 – WIRING & ADJUSTMENTS

Prior to installing wiring to the telephone entry system, we suggest that you become familiar with the instructions, illustrations, and wiring guidelines in this manual. This will help insure that you installation is performed in an efficient and professional manner.

The wiring of the telephone entry panel is an extremely important and integral part of the overall access control system. Use proper wire for the communication line, power wires, and be sure that the system is properly grounded. Check all local building ordinances and building codes prior to installing this system. Be sure your installation is in compliance with National Electric and local building codes.



WARNING! If this telephone entry system is used to control a vehicular gate with an automatic gate operator, the telephone entry system must be mounted a minimum of ten (10) feet away from the gate and gate operator or in such a way that a person cannot operate the entry system and touch the gate or gate operator at the same time. If this unit has not been installed in compliance with these instructions, do not proceed with any wiring until the unit has been moved and re-installed in accordance with these instructions.

Use only the supplied transformers (or U.L. listed equivalent) to power the telephone entry system (16.5 VAC, 20 VA, 60 Cycle). Do not connect the power transformer to a receptacle controlled by a switch.

Do not power any other devices (electric strikes, magnetic locks, etc.) from this power transformer. For wire runs up to 100 feet, use 18 AWG, 600 volt insulated wire. For wire runs up to 200 feet, use 16 AWG, 600 volt insulated wire. Power wires are susceptible to noise and hum pickup; therefore it is preferable that you keep power wire runs as short as possible.

This telephone entry system contains a number of static sensitive components that can be damaged or destroyed by static discharges during installation or use. Discharge any static prior to removing the circuit board from the lobby panel by touching a proper ground device.

Proper grounding of this system is a requirement. The use of surge suppressers can significantly reduce the chance of component failure because of static charges or surges. To be effective, ground connections should be made with a minimum 12 AWG, 600 volt insulated wire to a ground point within 10 feet of the telephone entry system. The ground point must be at an electrical panel, a metallic cold water pipe that runs in the earth, or a grounding rod driven at least ten (10) feet into the soil.

Be sure that you use proper wire that has an insulation rated for an underground environment. All wires should be placed in conduits. Proper pre-planning can greatly ease the installation and wiring of this system. Always check with the local building code to determine the type of wire required in your municipality.

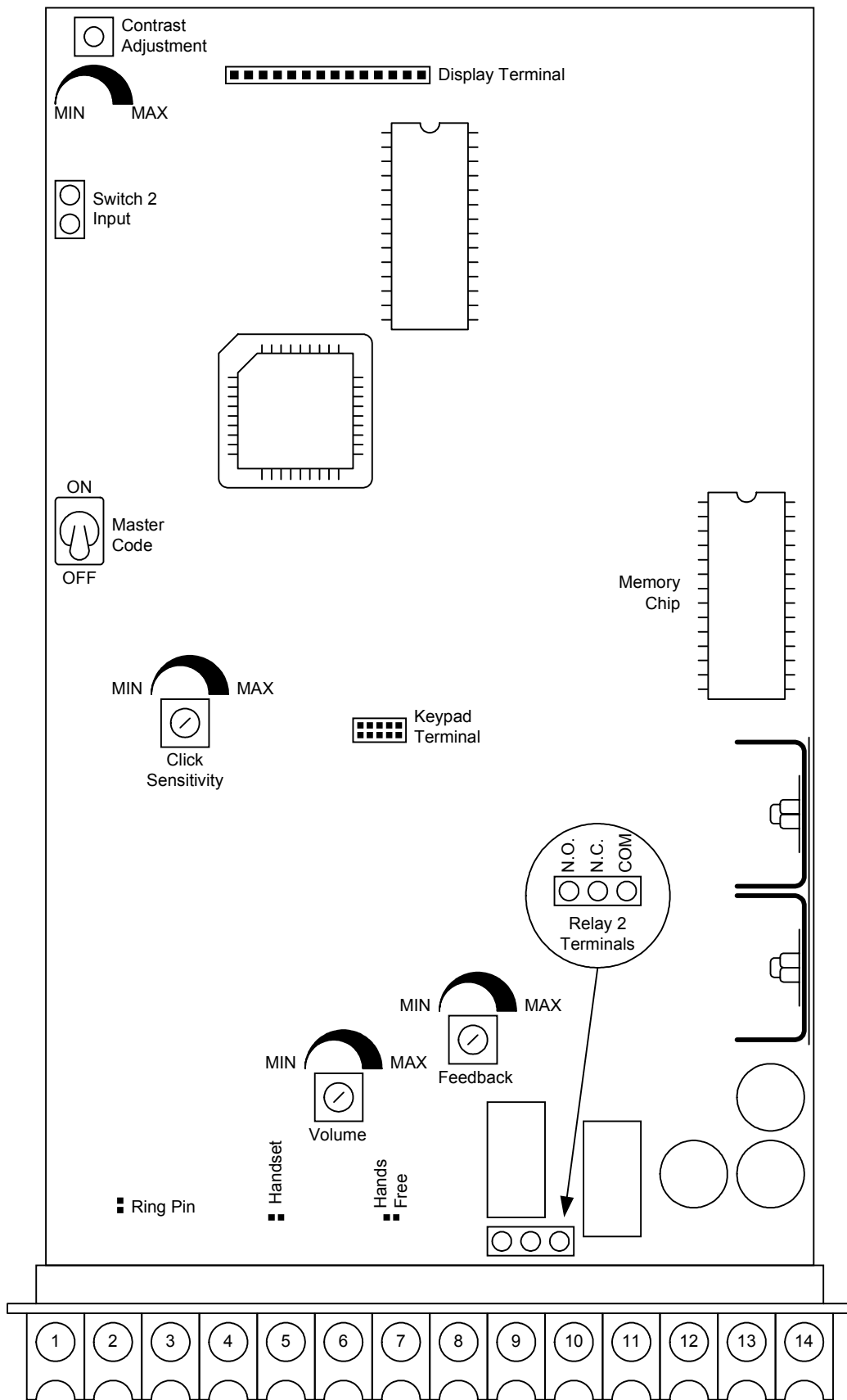

Field Wire Diagram - 1862-010 Control Board

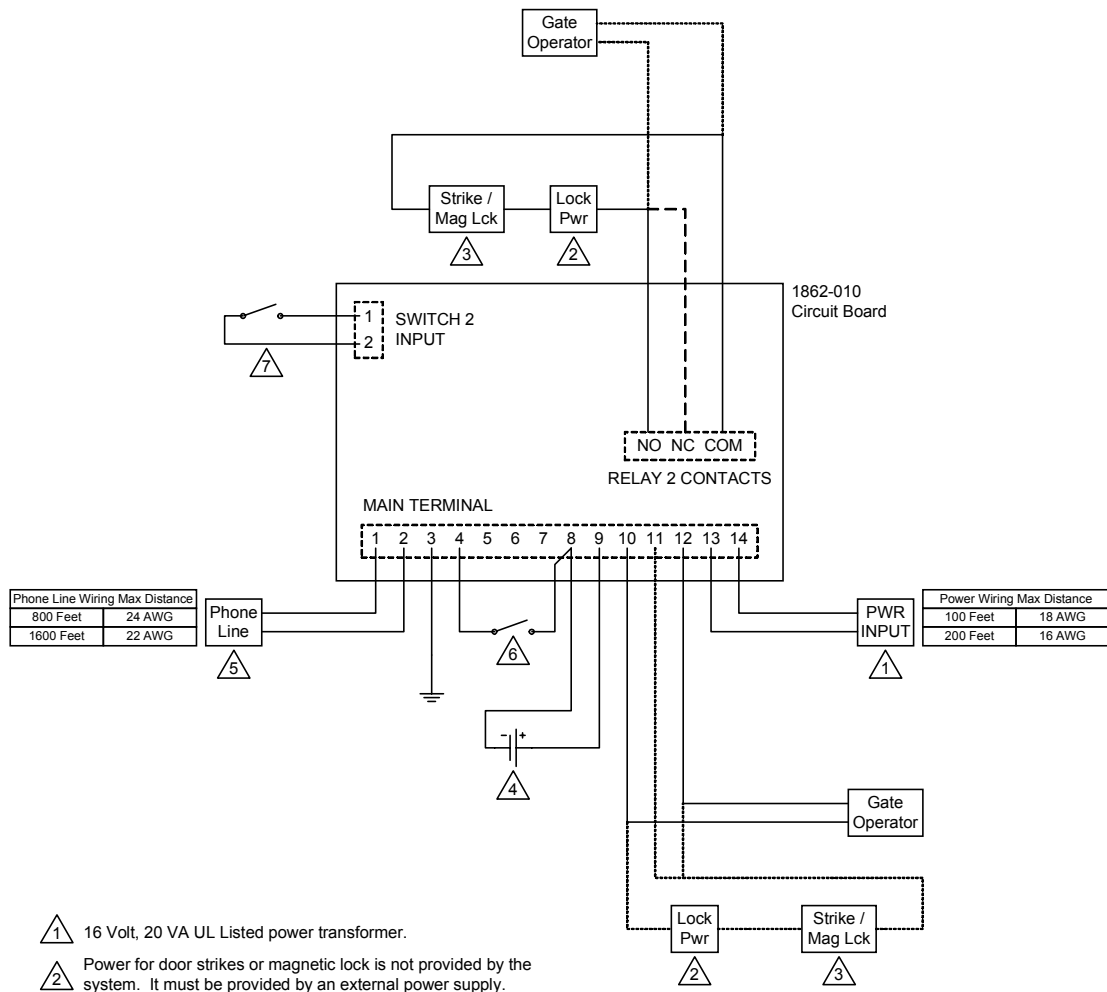

Phone Line Wiring Max Distance	
800 Feet	24 AWG
1600 Feet	22 AWG

Power Wiring Max Distance	
100 Feet	18 AWG
200 Feet	16 AWG

- ⚠️ 1 16 Volt, 20 VA UL Listed power transformer.
- ⚠️ 2 Power for door strikes or magnetic lock is not provided by the system. It must be provided by an external power supply.
- ⚠️ 3 Electric strikes are wired to Normally Open (N.O.) contacts; magnetic locks are wired to the Normally Closed (N.C.) contacts.
- ⚠️ 4 Optional 12 Volt gel cell for backup power.
- ⚠️ 5 Dedicated Central Office (C.O.) phone line - touch tone, loop start.
- ⚠️ 6 A switch closure across terminals 4 & 8 will activate relay 1 for its programmed strike time. This is where the postal switch is prewired.
- ⚠️ 7 A switch closure across these terminals will activate relay 2 for its programmed strike time or cause the system to dial a preprogrammed phone number. See 3.1.6.

All wiring to be performed in accordance with National Electric Code.

DOORKING, INC., INGLEWOOD, CA 90301		
Title: Field Wire Diagram - 1862 Control Board		
Date: 2/02	Dwg. No. MFW-1862-010	Rev. A

2.1 TERMINAL DESCRIPTION

MAIN TERMINAL	DESCRIPTION
1	Phone Line Connection – 800 ft. maximum with 24 AWG wire; 1600 ft. maximum with 22 AWG wire.
2	Phone Line Connection – 800 ft. maximum with 24 AWG wire; 1600 ft. maximum with 22 AWG wire.
3	Earth Ground Only – Not a Low Voltage Common!
4	Switch Input 1. A closure between terminals 4 and 8 will cause relay 1 to activate for the programmed strike time. The Postal Switch is connected here.
5	Microphone Input – White Wire.
6	Microphone Input – Green Wire.
7	Speaker Output.
8	Common for switch input 1, speaker and battery NEGATIVE (12 VDC).
9	Microphone Input – Red Wire and battery POSITIVE (12 VDC).
10	Relay 1 Common.
11	Relay 1 Normally Closed (N.C.).
12	Relay 1 Normally Open (N.O.).
13	16 VAC Input Power – 20 VA minimum. 100 ft. maximum with 18 AWG wire; 200 ft. maximum with 16 AWG wire.
14	16 VAC Input Power – 20 VA minimum. 100 ft. maximum with 18 AWG wire; 200 ft. maximum with 16 AWG wire.
RELAY 2 TERMINAL	DESCRIPTION
Left	Relay 2 Normally Open (N.O.).
Center	Relay 2 Normally Closed (N.C.).
Right	Relay 2 Common.
SWITCH 2 INPUT	DESCRIPTION
1 & 2	Switch Input 2. A closure between these terminals will cause relay 2 to activate for the programmed strike time or dial a preprogrammed phone number (see 3.1.6).

Do not run high voltage (115 V) power lines and communication lines in the same conduit. These should be in separate conduits at least six (6) inches apart. **Be sure that all phone line wiring is twisted and completely isolated from ground.**

Use only the supplied 16.5 VAC (or U.L. listed equivalent) to power the entry system. **Do not power any other devices (electric strikes, magnetic locks, lights, etc.) from this transformer.** Do not run 16 VAC entry system power lines over 200 feet. It is advisable to keep these wires as short as possible. **Use 18 AWG wire for wire runs up to 100 feet, and 16 AWG wire for wire runs up to 200 feet.** Install a low voltage surge suppresser (DoorKing p/n 1878-010 or equivalent) to help protect the entry system from power surges.

2.2 ADJUSTMENTS

2.2.1 Speaker Volume

1. Open the front of the telephone entry system and locate the speaker volume adjustment.
2. Place a phone call from the telephone entry system to a resident. While they are talking, adjust the speaker volume potentiometer for adequate sound. To increase the volume rotate the potentiometer clockwise, to decrease the volume rotate the potentiometer counter clockwise.

2.2.2 Feedback

1. Open the front of the telephone entry system and locate the feedback adjustment.
2. Place a phone call from the telephone entry system to a resident. After they answer, ask the resident to remain silent.
3. While rubbing your finger across the microphone hole, rotate the feedback potentiometer clockwise, and then counter clockwise. When the noise from the speaker is minimum, this is the correct adjustment for the feedback potentiometer.

2.2.3 Click Sensitivity

1. Open the front of the telephone entry system and locate the click sensitivity adjustment.
2. Place a phone call from the telephone entry system to a resident with a rotary dial type phone. After they answer, ask the resident to dial 9 while you adjust the click sensitivity potentiometer (the resident may have to dial 9 several times for you to obtain the correct adjustment). When the door or gate opens, this is the correct adjustment for the click sensitivity.
3. NOTE: Adjusting the click sensitivity too high (potentiometer fully clockwise) could cause the system to respond to loud noises while it is in use. If this happens, rotate the click sensitivity potentiometer counter clockwise 1/8 turn and re-test the system. You may have to perform this step several times to find the correct adjustment.

2.2.4 Display Contrast (1802, 1803, 1810 only)

1. Open the front of the telephone entry system and locate the contrast adjustment.
2. Turn the master code switch on. The display will read MST CODE. While the display is lighted, turn the contrast potentiometer clockwise and then counter clockwise until the display is satisfactory.
3. Turn the master code switch off.
4. NOTE: Approximately 30 seconds after the master code switch is turned on, the system will signal a long tone. This is normal and can be ignored. After the master code switch is turned off, the display will read MST CODE for approximately 30 seconds.

2.2.5 Master Code Switch

The master code switch is left in the off position for normal operation. Turn the master code switch on when setting the system master code. See programming instructions to set the system master code.

If the master code switch is turned on and a new master code is not entered, the system will sound a long tone after approximately 30 seconds. This tone will continue every 30 seconds until a new master code is entered, or until the switch is turned off. After the switch is turned off, the display (1802, 1803, 1810 only) will remain lit for approximately 30 seconds, and then will go off.

2.2.6 Ring Pin

The ring pin-shortening bar is labeled RING on the control board. This shortening pin must be installed to allow the system to answer any calls placed to it. If remote programming or remote relay operation is to be used, the shortening bar must be installed. Removing the shortening bar will cause the system to never answer any call placed to it.

2.2.7 Handset / Hands Free

The handset shortening pins are labeled HS, and the hands free shortening pins are labeled HF on the control board. The shortening bar is factory set and will be placed in the HF position for hands free operation, or will be placed in the HS position for those entry systems ordered with the optional handset. Do not place shortening bars on both the HS and HF pins at the same time.

SECTION 3 – PROGRAMMING

The DoorKing 1802, 1803, 1808 and 1810 Telephone Entry Systems can be programmed from the keypad on the front of the entry system, or remotely from an off premise location using a touch tone telephone. When programming from an off site location with a touch-tone telephone, the RING pin must be installed on the circuit board (see 2.2.6). We recommend that you do not attempt programming from an off site location until you become familiar with these programming instructions.

Programming from the Keypad

Follow the programming instructions as described in each section of this manual. The system will prompt you with short (beep) tones when programming steps have been followed correctly, and with a long tone (beeeeeep) when the programming step is ended. The 1802, 1803 and 1810 systems have an LCD display that will prompt you for information that you will need to enter.

Programming from an Offsite Location

Follow these steps when programming the system from an offsite location. You must use a touch-tone telephone and the RING pin must be installed to perform off site programming.

1. Call the telephone number that the entry system is installed on from a touch-tone telephone. The entry system will answer with a one second tone.
2. Follow the programming instructions as described in each section of this manual. The system will prompt you with short (beep) tones when programming steps have been followed correctly.
3. When complete, hang up. (You cannot use 0 # to end remote programming sessions).

Programming Notes

When each programming step is performed correctly, a short tone (beep) will be heard. When the programming session is ended, a long tone (beeeeeep) will be heard.

The blank symbol _ in the programming steps indicates numbers that you will need to enter, one number per blank.

The amount of telephone numbers that can be programmed into the system is dependent on the memory size ordered. Memory sizes available are 25 - 75 - 125 - 250 - 500 - 1000. The memory size also determines the number of four-digit entry codes (memory size + 12) that can be programmed into the system. Five-digit entry codes are limited to six.

3.1 GENERAL PROGRAMMING

3.1.1 Master Code

This programming step sets the system MASTER CODE. The master code is the four-digit number required to gain access to the system memory. You need to know the master code prior to performing any of the programming functions on the following pages.

NOTE: The master code cannot be programmed from an off-site location. The master code can only be programmed from the system keypad.

Factory setting = 9999

1. Open the cabinet of the telephone entry system and turn the master code switch (the small toggle switch) on.
2. Enter a four-digit master code ____ then press * (beep).
3. Turn the master code switch off and close the cabinet.

3.1.2 Single or Multiple Systems

This program sequence sets the telephone entry system to operate as a single unit on the phone line, or to share the phone line with other units. If multiple systems are sharing the same phone line, then each one must be set as a "multiple system" and each must have a unique master code.

Factory setting = 0 (Single System).

1. Press *04 and then enter the four-digit MASTER CODE ____ (beep).
2. Enter 0* (beep) for a single system **or** 1* (beep) for multiple systems.
3. Press 0# TOGETHER to end this programming step (beeeeeep).

3.1.3 Relay Strike Time

These steps will program Relay 1 and Relay 2 strike times. Strike times can be programmed from 1/4 second (enter 00 in step 3) up to 99 seconds by entering the desired time in seconds.

Factory setting for relay strike times are: Relay 1 = 01, Relay 2 = 01.

1. Press *03 and enter the four-digit MASTER CODE ____ (beep).
2. Press 1* to set relay 1, **or** 2* to set relay 2 strike time.
3. Enter the two-digit strike time __ (00-99) then press * (beep).
4. Repeat steps 2 and 3 to set the other relay strike time.
5. Press 0# TOGETHER to end this programming step (beeeeeep).

3.1.4 Talk Time

This programming sequence sets the maximum time allowed for conversation when the entry system places a call to the resident. The talk time can be set from 1 second up to 255 seconds (4 minutes, 15 seconds) and is entered as a three-digit number. For example, to set a talk time of 20 seconds, enter 020 in step 3. The talk time set here does not affect the telephone numbers that are programmed under directory codes 0, 00, 000, 0000 and 1, 01, 001, 0001. The talk time for these two directory codes are factory set to the maximum. Phone numbers programmed under these directory codes should be reserved for management or emergency phone numbers that generally require longer conversations.

Factory setting for talk time = 060 (60-sec).

1. Press *08 and enter the four digit MASTER CODE ____ (beep).
2. Enter three digits for talk time (seconds) ___ (001-255) then press * (beep).
3. Press 0# TOGETHER to end this programming step (beeeeeep).

3.1.5 Tone Open Numbers

These steps will program the tone open numbers for relays 1 and 2. You will need to enter a four-digit number (see chart below) to set the relay functions. If a function is not desired, enter # in place of a number. For example, if you want the relay to have a momentary activation function only, and you want the relay to activate when the number 9 is pressed, enter 9#### in step 3. Do not duplicate tone open numbers, i.e., don't set relay 1, and 2 tone-open numbers to 9.

Factory setting is: Relay 1 = 9876, Relay 2 = 5432.

1. Press *05 and enter the four-digit MASTER CODE ____ (beep).
2. Press 1* to set relay 1 **or** 2* to set relay 2 tone numbers.
3. Enter the four-digit tone open number code ____ then press * (beep).
4. Repeat steps 2 and 3 to set the other relay tone open numbers.
5. Press 0# TOGETHER to end this programming step (beeeeeep).

DIGIT	FUNCTION
1	Momentary activation. Relay will activate for the programmed strike time (3.1.3).
2	Relay hold. Relay will activate and remain activated until commanded to release.
3	Relay release. Deactivates the relay hold command.
4	Relay hold 1-hour. Relay will activate for 1-hour and then will automatically deactivate itself.

3.1.6 Postal Switch

This programming sequence will set how the two switch inputs on the telephone entry system control board will operate. Switch input 1 is labeled PSW (postal switch) and is found on terminal 4 of the main terminal strip. Switch input 2 is a two terminal auxiliary input located on the upper left hand corner of the control board. These switch inputs can be programmed to activate their respective relays (switch 1 - relay 1, switch 2 - relay 2). They can also be programmed so that switch 1 dials out the phone number programmed in directory code 0, 00, 000, or 0000, and switch 2 dials out the phone number programmed in directory code 1, 01, 001, or 0001. Each switch is programmed independently.

Factory setting is: Switch input 1 = 0 (relay 1 activates), Switch input 2 = 0 (relay 2 activates).

1. Press *23 and enter the four-digit MASTER CODE ____ (beep).
2. Press 1* (beep) to set switch 1, **or** press 2* (beep) to set switch 2.
3. Press 0* (beep) to set the switch input to activate the relay, **or** press 1* (beep) to set the switch input to dial-out a preprogrammed phone number.
4. Press 0# TOGETHER to end this programming step (beeeeeep).

3.1.7 Touch-tone / Rotary-dial

This programming sequence will set the telephone entry system to dial out in either a touch-tone or rotary format. Generally, this will be set for touch-tone.

Factory setting = 0 (touch-tone).

1. Press *07 and enter the four digit MASTER CODE ____ (beep).
2. Enter 0* (beep) for touch-tone **or** enter 1* (beep) for rotary.
3. Press 0# TOGETHER to end this programming step (beeeeeep).

3.1.8 Number of Rings to Answer

This programming sequence sets the number of rings to allow before the telephone entry system answers a call placed to it. This programming sequence does not affect the number of times that a resident's telephone will ring when a call is placed from the entry system to the resident.

Factory setting = 02 (two rings).

1. Press *18 and enter the four-digit MASTER CODE ____ (beep).
2. Enter the number of rings __ then press * (beep).
3. Press 0# TOGETHER to end this programming step (beeeeeep).

3.1.9 Keypad Function

This programming sequence sets the function of the 0 through 9, and the # keys on the keypad during conversation. The keys can be set to hang-up the entry system when they are pressed during conversation, or they can be programmed to DTMF tone out during conversation. The later may be desirable if the entry system is used with an auto-attendant type telephone system where the caller is prompted to enter numbers from a touch-tone telephone. HINT: If DTMF tones are required, program the # or * key to hang-up the system.

Factory setting = 0 for all numbers (hang-up).

1. Press *26 and enter the four-digit MASTER CODE ____ (beep).
2. Enter the desired key number _ then press * (beep).
3. Press 0* (beep) for hang-up, or press 1* (beep) for touch-tone.
4. Repeat steps 2 and 3 to program other keys.
5. Press 0# TOGETHER to end this programming step (beeeeeep).

3.1.10 Star (*) Key Function

This programming sequence sets the function of the * key on the keypad during conversation. This key can be set to hang-up the entry system when pressed during conversation, or it can be programmed to touch-tone out during conversation.

Factory setting = 0 (hang-up).

1. Press *27 and enter the four-digit MASTER CODE ____ (beep).
2. Press 0* (beep) for hang-up, or press 1* (beep) for touch-tone.
3. Press 0# TOGETHER to end this programming step (beeeeeep).

3.2 PHONE NUMBER PROGRAMMING

3.2.1 Programming the Directory Code Length

This programming sequence sets the directory code length to 1 - 2 - 3 or 4 digits. If 11 or more resident names or telephone numbers are going to be programmed into the system, the directory code must be at least two-digits. If 101 or more resident names or telephone numbers are going to be programmed, the directory code must be at least three-digits.

Factory setting is three (3) digits.

CAUTION: This programming sequence will delete all phone numbers and directory codes that have been previously programmed into the system.

1. Press *20 and enter the four-digit MASTER CODE ____ (beep).
2. Enter the directory code digit length (1-2-3 or 4) then press * (beep). This programming sequence will automatically end itself. This will be indicated by a long tone (beeeeeep).

3.2.2 Programming 7-digit Phone Numbers

In this programming sequence, the directory codes and 7-digit phone numbers will be programmed into the system. Be sure you have programmed the directory code length that you desire as described in 3.2.1. **Changing the directory code length after programming the telephone numbers will erase all the numbers and directory codes that have been programmed.** To program phone numbers that will be referenced to an area code (long distance calls and 10 digit calling), follow the instructions under Long Distance Phone Number Programming on the next page. If you use directory codes 0, 00, 000, 0000 and/or 1, 01, 001, 0001 remember that the talk time for these directory codes are factory set to the maximum and cannot be changed. Use these directory codes to program management or emergency phone numbers, which generally require longer conversation periods.

NOTE: If this telephone entry system is being used in an area that requires 10-digit dialing, proceed to 3.2.3 and 3.2.4 to program the area code and phone number.

1. Press *01 and enter the four-digit MASTER CODE ____ (beep).
2. Enter the directory code (1, 2, 3 or 4 digits depending on what was programmed in 3.2.1) then press * (beep).
3. Enter the seven-digit phone number _____ then press * (beep). If the number that you are entering in this step is less than seven-digits, enter # in the empty spaces. For example, if the system is connected to a PBX that requires four-digit extension numbers and you want to enter extension 2217, you would enter this number as 2217#### then press * (beep).
4. Repeat steps 2 and 3 to enter additional directory codes and phone numbers.
5. Press 0# TOGETHER to end this programming step (beeeeeep).

3.2.3 Programming Area Codes

Up to 10 different area codes can be programmed for any 10-digit or long distance calling requirements and will be referenced 0 through 9 (for a total of 10). The area codes will be entered as a four-digit number (1 + the three digit area code). If area codes are being programmed to facilitate 10-digit calling requirements, precede the three-digit area code with #.

1. Press *24 and enter the four-digit MASTER CODE ____ (beep).
2. Enter a 1-digit area code reference number (0 through 9) then press * (beep).
3. Enter the area code ____ then press * (beep). NOTE-1: for long distance calling requirements, enter 1 and the three-digit area code. NOTE-2: for 10-digit calling requirements, enter # and the three-digit area code.
4. Repeat steps 2 and 3 to enter additional area codes. Remember to use a different area code reference number when entering more area codes.
5. Press 0# TOGETHER to end this programming step (beeeeeep).

3.2.4 Programming Phone Numbers with Area Code Reference

In this section, phone numbers that are referenced to an area code (long distance and 10-digit dialing calls) will be programmed. Be sure that the area code(s) have been programmed as described in the preceding section.

NOTE: If long distance or 10-digit dialing is not required, program the seven digit telephone numbers as described in 3.2.2.

1. Press *41 and enter the four-digit MASTER CODE ____ (beep).
2. Enter a directory code (1, 2, 3 or 4 digits depending on what was programmed in 3.2.1) then press * (beep).
3. Enter the area code reference number _ then press * (beep).
4. Enter the seven-digit phone number _____ then press * (beep). If the number that you are entering in this step is less than seven-digits, enter # in the empty spaces. For example, if the system is connected to a PBX that requires four-digit extension numbers and you want to enter extension 2217, you would enter this number as 2217### then press * (beep).
5. Repeat steps 2, 3, and 4 to enter additional long distance phone numbers.
6. Press 0# TOGETHER to end this programming step (beeeeeep).

3.2.5 Deleting Individual Phone Numbers

This programming sequence is used to delete a single phone number under a known directory code.

1. Press *01 and enter the four-digit MASTER CODE ____ (beep).
2. Enter the directory code of the phone number to be deleted (1, 2, 3 or 4 digits depending on what was programmed in 3.2.1) then press * (beep).
3. Press ##### then press * (beep).
4. Repeat steps 2 and 3 to delete additional phone numbers.
5. Press 0# TOGETHER to end this programming step (beeeeeep).

3.2.6 Delete All Phone Numbers

This programming step deletes all phone numbers previously programmed into the system.
CAUTION: this programming step is irreversible once it is started.

1. Press *22 and enter the four-digit MASTER CODE ____ (beep).
2. Press 9999 then press * (beep). This programming sequence will automatically end itself. This will be indicated by a long tone (beeeeeep).

Sections 3,2,7 and 3.2.8 apply only to 1802, 1803 and 1810 units.

3.2.7 Display / Delete Phone Numbers

This program sequence is useful to display phone numbers when you do not know what directory code they have been programmed under. This sequence also gives you the option to delete the phone number after it is displayed.

1. Press * 25 and enter the four-digit MASTER CODE ____ (beep).
2. The first directory code will be displayed. Press * to view the phone number programmed under this directory code. If the first digit is flashing, this is the area code reference number and indicates a long distance phone number.
3. Press * to go to the next step.
4. Press * to move forward to the next directory code, **or** press 0 to delete the shown phone number and move forward to the next directory code.
5. After the last phone number is displayed and * or 0 is pressed, this programming sequence will automatically end itself. This will be indicated by a long tone (beeeeeep) **or** you can press 0#TOGETHER to end this programming step at any time (beeeeeep).

3.2.8 Display Phone Numbers with known Directory Codes

Use this programming sequence to display phone numbers programmed under known directory codes, i.e. if you wanted to see what phone number was programmed under directory code 2719 (assuming directory codes have been programmed for four digits). This programming sequence will not allow you to delete phone numbers.

1. Press *06 and enter the four-digit MASTER CODE ____ (beep).
2. Enter the directory code of the users phone number that you wish to display (1, 2, 3 or 4 digits depending on what was programmed in 3.2.1).
3. The phone number programmed under the directory code entered in step 2 will be displaced on the programming display. If C C C C C C is displayed, this indicates that no phone number has been programmed under the entered directory code. If the first digit is flashing, this is the area code reference code and indicates that the number displayed is a long distance number.
4. To display additional phone numbers press * and repeat step 2.
5. Press 0# TOGETHER to end this programming step (beeeeeep).

3.3 ENTRY CODE PROGRAMMING

3.3.1 Four-Digit Entry Code Programming

This programming sequence programs four-digit entry codes into the system memory. The number of four-digit entry codes that can be programmed is the same as the telephone number memory capacity, plus 12. We suggest that all entry codes that are programmed into the system be listed with the names of persons that they have been assigned to (see appendix).

1. Press *02 and enter the four-digit MASTER CODE ____ (beep).
2. Enter the four-digit entry code ____ then press * (beep).
3. Repeat step 2 to enter additional entry codes.
4. Press 0# TOGETHER to end this programming step (beeeeeep).

3.3.2 Delete Four-Digit Entry Codes

1. Press *14 and enter the four-digit MASTER CODE ____ (beep).
2. Enter the four-digit entry code ____ to be deleted and then press * (beep).
3. Repeat step 2 to delete more entry codes.
4. Press 0# TOGETHER to end this programming step (beeeeeep).

3.3.3 Delete All Four-Digit Entry Codes

This programming sequence deletes all four-digit entry codes that have been programmed into the system. CAUTION: this programming step is irreversible once it is started.

1. Press *00 and enter the four-digit MASTER CODE ____ (beep).
2. Press 9999 then press * (beep). This programming sequence will automatically end itself. This will be indicated by a long tone (beeeeeep).

3.3.4 Four-Digit Entry Code Divide Number

The four-digit entry codes can be made to activate either relay 1 or relay 2 by programming a four-digit divide number. Four-digit entry codes equal to or less than the divide number will activate relay 1. Four-digit entry codes greater than the divide number will activate relay 2. HINT: you can make all four-digit entry codes (except 0000) activate relay 2 by programming divide number 0000, or make all four-digit entry codes activate relay 1 by programming divide number 9999.

The factory default divide number is 9999.

1. Press *12 and enter the four-digit MASTER CODE ____ (beep).
2. Enter the four-digit divide number ____ then press * (beep).
3. Press 0# TOGETHER to end this programming step (beeeeeep).

3.3.5 Five-Digit Entry Code Programming

This programming sequence programs five-digit entry codes into the system memory. The number of five digit entry codes that can be programmed is limited to six. We suggest that all entry codes that are programmed into the system be listed with the names of persons that they have been assigned to (see appendix).

1. Press *09 and enter the four-digit MASTER CODE ____ (beep).
2. Enter the five-digit entry code _____ then press * (beep).
3. Repeat step 2 to enter additional entry codes.
4. Press 0# TOGETHER to end this programming step (beeeeeep).

3.3.6 Delete Five-Digit Entry Codes

1. Press *10 and enter the four-digit MASTER CODE ____ (beep).
2. Enter the five-digit entry code _____ then press * (beep).
3. Repeat step 2 to delete more entry codes.
4. Press 0# TOGETHER to end this programming step (beeeeeep).

3.3.7 Delete All Five-Digit Entry Codes

This programming sequence deletes all five-digit entry codes that have been programmed into the system. CAUTION: this programming step is irreversible once it is started.

1. Press *11 and enter the four-digit MASTER CODE ____ (beep).
2. Press 9999 then press * (beep). This programming sequence will automatically end itself. This will be indicated by a long tone (beeeeeep).

3.3.8 Five-Digit Entry Code Divide Number

The five-digit entry codes can be made to activate either relay 1 or relay 2 by programming a five-digit divide number. Five-digit entry codes equal to or less than the divide number will activate relay 1. Five-digit entry codes greater than the divide number will activate relay 2. HINT: you can make all five-digit entry codes (except 00000) activate relay 2 by programming divide number 00000, or make all five-digit entry codes activate relay 1 by programming divide number 99999.

1. Press *13 and enter the four-digit MASTER CODE ____ (beep).
2. Enter the five-digit divide number _____ then press * (beep).
3. Press 0# TOGETHER to end this programming step (beeeeeep).

3.4 TIME FUNCTIONS PROGRAMMING

3.4.1 Time Clock Programming

This programming sequence programs the calendar chip in the telephone entry system for the current time and date. The calendar chip must be programmed if you are going to use any of the time functions available with the entry system.

1. Press *33 and enter the four-digit MASTER CODE ____ (beep).
2. Enter the current hour and minutes ____ then press * (beep). Do not use military (24 hour) time format, simply enter the hour (2 digits) and the minutes (2 digits). For example, 8:30 is entered as 0830 whether it is AM or PM.
3. Press 0* (beep) for AM, **or** press 1* (beep) for PM.
4. Enter the month __ then press * (beep).
5. Enter the day of the month __ then press * (beep).
6. Enter the year __ then press * (beep).
7. Enter the day of the week _ (Sun = 1, Sat = 7) then press * (beeeeeep).

3.4.2 Automatic Relay Activation Time Zones

This program sequence sets up time zones to automatically activate and deactivate the relays on the control board. Each relay can be programmed with two independent time zones. Time zones 1 and 2 affect relay 1 operation; time zones 3 and 4 affect relay 2 operation. Use the chart in the appendix to record the time zones that are programmed. These time zones can be independently turned on or turned off after they have been programmed (see operating instructions 5.2.5).

1. Press *35 and enter the four-digit MASTER CODE ____ (beep).
2. Enter a time zone number (1, 2, 3 or 4) then press * (beep).
3. Press 1* (beep) to turn the time zone ON, **or** press 0* (beep) to turn the time zone OFF.
4. Enter the beginning hour and minutes ____ then press * (beep).
5. Press 0* (beep) for AM, **or** press 1* (beep) for PM.
6. Enter the ending hour and minutes ____ then press * (beep).
7. Press 0* (beep) for AM, **or** press 1* (beep) for PM.
8. Enter the days of the week _____ then press * (beep). To skip any days of the week, enter # in place of the day. For example, to have a time zone active on Saturday and Sunday only (Sun = 1, Sat = 7), enter 1 7 # # # # #.
9. Repeat steps 2 through 8 to enter additional time zones.
10. Press 0# TOGETHER to end this programming step (beeeeeep).

3.4.3 Four-Digit Entry Code Time Zone

This programming sequence sets up a time zone for the four-digit entry codes. This time zone uses a range of four-digit entry codes and can be programmed for certain days of the week. This time zone can be turned on and turned off after it is programmed (see operating instructions 5.2.4).

1. Press *36 and enter the four-digit MASTER CODE ____ (beep).
2. Press 1* (beep) to turn the time zone ON, **or** press 0* (beep) to turn the time zone OFF.
3. Enter the beginning hour and minutes __ __ __ then press * (beep). (Four-digit entry codes that are within the boundaries of the time zone will begin to work at this time.)
4. Press 0* (beep) for AM, **or** press 1* (beep) for PM.
5. Enter the ending hour and minutes __ __ __ then press * (beep). (Four-digit entry codes that are within the boundaries of the time zone will cease to work at this time.)
6. Press 0* (beep) for AM, **or** press 1* (beep) for PM.
7. Enter the days of the week __ __ __ __ __ then press * (beep). To skip any days of the week, enter # in place of the day. For example, to have a time zone active on Saturday and Sunday only (Sun = 1, Sat = 7), enter 1 7 # # # # #.
8. Enter the lower four-digit boundary ____ then press * (beep).
9. Enter the upper four-digit boundary ____ then press * (beep).
10. Press 0# TOGETHER to end this programming step (beeeeeep).

3.4.4 Five-Digit Entry Code Time Zone

This programming sequence sets up a time zone for the five-digit entry codes. This time zone uses a range of five-digit entry codes and can be programmed for certain days of the week. This time zone can be turned on and turned off after it is programmed (see operating instructions 5.2.4).

1. Press *37 and enter the four-digit MASTER CODE ____ (beep).
2. Press 1* (beep) to turn the time zone ON, **or** press 0* (beep) to turn the time zone OFF.
3. Enter the beginning hour and minutes __ __ __ __ then press * (beep). (Five-digit entry codes that are within the boundaries of the time zone will begin to work at this time.)
4. Press 0* (beep) for AM, **or** press 1* (beep) for PM.
5. Enter the ending hour and minutes __ __ __ __ then press * (beep). (Five-digit entry codes that are within the boundaries of the time zone will cease to work at this time.)
6. Press 0* (beep) for AM, **or** press 1* (beep) for PM.
7. Enter the days of the week __ __ __ __ __ then press * (beep). To skip any days of the week, enter # in place of the day. For example, to have a time zone active on Saturday and Sunday only (Sun = 1, Sat = 7), enter 1 7 # # # # #.
8. Enter the lower five-digit boundary ____ then press * (beep).
9. Enter the upper five-digit boundary ____ then press * (beep).
10. Press 0# TOGETHER to end this programming step (beeeeeep).

3.4.5 Flash Entry Codes

This programming sequence sets up "FLASH" four-digit entry codes. Flash codes are entry codes that will operate on a specific day of the month only - they will not operate before or after the programmed day. The flash code will be valid for a single 24-hour period only. For example, if you program a flash code on July 1st to be active on the 10th, the code will become valid at 00:00 AM on July 10th and expire at 11:59 PM. The code will not be valid on August 10th. You can program up to eight flash codes in the system. Flash codes 1 through 4 will activate relay 1, flash codes 5 through 8 will activate relay 2.

1. Press *15 and enter the four-digit MASTER CODE ____ (beep).
2. Enter a flash code number (1 - 8) then press * (beep).
3. Enter the day of the month that the code is to be active __ then press * (beep).
4. Enter a four-digit FLASH ENTRY CODE ____ then press * (beep).
5. Repeat steps 2 through 4 to enter additional flash codes.
6. Press 0# TOGETHER to end this programming step (beeeeeep).

SECTION 4 – OPERATING INSTRUCTIONS

Never allow children to operate or play with any access control device.

4.1 GENERAL INSTRUCTIONS

4.1.1 Guest Instructions

Instructions on the faceplate of the unit will instruct guest on the operation of the telephone entry system. Guests will locate a residents name and directory code in a directory associated with the telephone entry system. This may be a letter board type directory, an add-on directory or a built-in directory like that found in the 1810 unit.

When a directory code is entered on the keypad, the telephone entry system will call the preprogrammed telephone number stored under that directory code. If the line is busy, the system will emit a busy signal. Pressing the hang-up key (any key or the preprogrammed hang-up key) will hang the system up. Guest can then try again. Residents can avoid missing calls from the telephone entry system by ordering call waiting from the local telephone company.

The system can be programmed so that the keypad emits DTMF tones after a connection is made. For example, in a business application, a call from the telephone entry system may be answered by an auto-attendant requesting that you enter a person's extension number. This is possible with the system provided that it has been programmed to emit DTMF tones once the call is answered.

4.1.2 Responding to a Guest Call

When communication is established, the resident has the option of opening the door(s) or gate(s) by pressing the programmed tone open number(s) on their touch tone telephone, or they can deny access to their guest by pressing # on their telephone. If access is granted, the resident will hear a confirmation tone in their handset indicating that the door or gate has opened, then the system will automatically hang up.

Residents should be instructed by management to always press the # key on their telephone if they wish to deny a guest access. If a resident hangs up to deny access instead of pressing #, the telephone entry system will remain on line until its programmed talk time expires or until it detects dial tone.

Some newer type telephones emit a short tone rather than a continuous tone when their keys are pressed. This may cause the telephone entry system to not respond to the tone open number. If this happens, simply press the tone open number twice in rapid succession to open the door or gate.

If a resident is using rotary dial telephone, they will grant access to their guest by dialing 9. To deny access to their guest, residents with rotary phones must simply hang up.

4.1.3 Using an Entry Code

The four and five-digit entry codes will operate either relay 1, relay 2, or they can be programmed so that certain codes will activate only relay 1 while others will activate only relay 2. Both four and five-digit entry codes can be time zone restricted.

1. To use four-digit codes, press # and then enter the four-digit entry code ____ .
2. To use five-digit codes, press ## and then enter the five-digit entry code _____ .

If management decides to utilize resident entry codes, residents should be instructed to keep their unique code secret. Telling other persons their code or allowing other persons to use their code compromises security and defeats the purpose of the system.

4.2 SYSTEM ADMINISTRATOR

The administrator can perform the following operations from a remote location using a touch-tone telephone. You must know the phone number of the system and the system master code.

4.2.1 Remote Programming

1. Call the telephone number that the entry system is installed on. The system will answer with a short tone (beep). Note: the number of rings before the system answers is dependent on the programming in 3.1.8.
2. After the system answers, follow the desired programming steps in Section 3.
3. When complete, hang up. You cannot use 0# together to end the programming step from a touch-tone telephone.

4.2.2 Remote Relay Activation

1. Call the telephone number that the entry system is installed on. The system will answer with a short tone (beep). Note: the number of rings before the system answers is dependent on the programming in 3.1.8.
2. Press *16 and enter the four-digit MASTER CODE ____ (beep).
3. Press the desired tone open number _ (beep). NOTE: Refer to 3.1.5 to determine which tone open features have been programmed, i.e. momentary open, hold open, release, hold open one hour and then release.
4. Hang up.

4.2.3 Relay Check

The telephone entry system can be called and a check can be made to determine if any of the relays in the system are in a "hold open" mode. This check can be useful if your gate (or door) is held open and you suspect that the telephone entry system relay may be the cause.

1. Call the telephone number that the entry system is installed on. The system will answer with a short tone (beep). Note: the number of rings before the system answers is dependent on the programming in 3.1.8.
2. Press *16 and enter the four-digit MASTER CODE ____ (beep).
3. The system will emit a series of short tones if the relay is in a continuous activation mode.
 - Relay 1 activated: beep - pause - beep - pause . . .
 - Relay 2 activated: beep beep - pause - beep beep - pause . . .
 - Relay 1 & 2 activated: beep beep beep - pause - beep beep beep - pause . . .
4. Press the programmed tone number _ to deactivate the relay (beep). The system will automatically hang up.

4.2.4 Entry Code Time Zone Enable / Disable

The entry code time zones can be turned off or on remotely from a touch-tone telephone at any time without changing the time zone boundaries. To program the time zone boundaries, see sections 3.4.3 and 3.4.4. Entry code time zones can also be turned off or on at the system keypad by skipping step 1 and proceeding directly to step 2 in the sequence below.

1. Call the telephone number that the entry system is installed on. The system will answer with a short tone (beep). Note: the number of rings before the system answers is dependent on the programming in 3.1.8.
2. Press *36 for four-digit entry code time zones **or** press *37 for five-digit entry code time zones and enter the four-digit master code ____ (beep).
3. Press 0* (beep) to turn the time zone OFF, **or** press 1* (beep) to turn the time zone ON.
4. Hang up or if at the system keypad, press 0# together (beeeeeep).

4.2.5 Auto Relay Time Zone Enable / Disable

The four time zones that automatically activate and deactivate the relays can be turned off or on from a touch-tone telephone at any time without changing the time zone boundaries. To program the auto relay activation time zone boundaries, see section 3.4.2. Auto relay time zone boundaries can also be turned off or on at the system keypad by skipping step 1 and proceeding directly to step 2 in the sequence below.

1. Call the telephone number that the entry system is installed on. The system will answer with a short tone (beep). Note: the number of rings before the system answers is dependent on the programming in 3.1.8.
2. Press *35 and enter the four-digit master code ____ (beep).
3. Enter the time zone number _ that you want to turn off **or** on, then press * (beep).
4. Press 0* (beep) to turn the time zone OFF, **or** press 1* (beep) to turn the time zone ON.
5. Hang up or if at the system keypad, press 0# together (beeeeeep).

4.3 MISCELLANEOUS OPERATING INSTRUCTIONS

4.3.1 Switch Input Operation

The two switch inputs can be programmed to either activate their respective relay (switch 1 input activates relay 1; switch 2 input activates relay 2) or they can be programmed to call the phone number programmed under the first two directory codes (switch 1 input calls the phone number programmed under directory code 0, 00, 000 or 0000; switch 2 input calls the phone number programmed under directory code 1, 01, 001 or 0001). Each switch input is programmed independently (3.1.6).

Switch 1 input is typically used as the postal switch and is pre-wired and pre-programmed for postal switch operation. We suggest that switch input 1 should be left programmed to activate relay 1 to allow the mail carrier entry.

Switch 2 input can be programmed as the application requires. For example, if the telephone entry system is controlling a vehicular gate with relay 1 and a pedestrian gate with relay 2, a postal lock box (DoorKing P/N 1402-080) could be installed at the pedestrian gate for the mail carrier and connected to switch input 2. In this manner, the postal lock box would allow the mail carrier access through the pedestrian gate when it is activated. Another use of switch input 2 is to program the input to call a preprogrammed telephone number instead of activating relay 2. An auxiliary button can be installed and connected to switch input 2 and labeled "assistance." When the button is pressed, the system will automatically dial the phone number programmed under directory code 1, 01, 001 or 0001.

4.3.2 Talk Time

The talk time for directory codes 0, 00, 000, 0000 and 1, 01, 001, 0001 is factory set to 4 minutes 15 seconds and cannot be changed. These directory codes should be reserved for use with management or emergency phone numbers that typically require longer talk times. For example, if directory code 000 was programmed to call a management phone number, the system will allow the full 4 minutes and 15 seconds of talk time before automatically ending the call.

4.3.3 Line Sharing

More than one telephone entry system can share the same phone line provided that the units have been programmed for multiple systems on the same line (see 3.1.2). When the unit is programmed for multiple systems sharing the same line, it checks the phone line for 48 volts (not busy) before attempting to place a call. If the phone line is in use, the system will emit a busy signal. If two or more systems are sharing the same phone line, it is important that each system be programmed with its own unique master code. When more than one system is on the same phone line, and a call is placed from one of the systems to a resident, only the system that placed the call will respond to any tone open numbers. Do not be concerned that all the units will activate their relay when the resident presses the tone open number.

4.3.4 Connection to a PBX

If the telephone entry system is going to be connected to a PBX system, you may need to program extension numbers in place of a seven-digit telephone number. To do this, enter the extension number and fill the remaining spaces with the # key in the phone number programming step. For example, if the PBX system uses four-digit extensions and you want to program extension 2217 as a phone number, in step 3, section 3.2.2 press:

3. 2 2 1 7 # # # * (beep).

If the PBX system requires you to dial 9 to obtain an outside line, and you want to program some outside line phone numbers in the system, program the number 9 as one of the alternate area codes. In step 3, section 3.2.3 press:

3. 9 # # # *(beep).

Then program the outside phone number as a long distance number (3.2.4) using the area code reference number used to program 9.

4.3.5 Areas with 10-digit Dialing

If the telephone entry system is installed in an area where the telephone company has instituted 10 digit dialing, simply program the required number of alternate area codes into the system without preceding the area code with the number 1. If 310 was one of the area codes required, in step 3, section 3.2.3 press:

3. 3 1 0 # * (beep).

Then program the outside phone number as a long distance number (3.2.4) using the area code reference number used to program 310. Program additional area codes and phone numbers as described in sections 3.2.3 and 3.2.4.

SECTION 5 – MAINTENANCE

The DoorKing telephone entry system is essentially a maintenance free device. When the unit is properly installed, it should provide years of trouble free service. Maintenance is limited to updating the directory and phone number and/or entry codes when residents move in or out.

The faceplate of the unit should be cleaned on a regular basis to keep contaminants in the air from sticking to the surface and possibly causing pitting. When cleaning the faceplate of the system, never use an abrasive cleaner or cloth. Stainless steel cleaner works very well with a soft cloth for systems with a stainless steel faceplate. A clean damp soft cloth should be used to clean gold plated faceplates.

5.1 REPLACEMENT PARTS

The following items are replaceable and can be ordered from your installing dealer.

Light Bulb	GE 1893 – DoorKing P/N 1808-005
Keypad	Replacement keypad – DoorKing P/N 1804-055 Replacement keypad gold – DoorKing P/N 1804-037
Transformer	Replacement power transformer – 16 VAC, 20 VA U.L. Listed DoorKing P/N 1804-060

5.2 TROUBLE SHOOTING

If problems should develop with your telephone entry system, refer to the trouble-shooting guide on the following pages to try and correct any problems. Our experience has shown that a majority of reported problems are actually programming related and can be corrected on site. If problems persist and they cannot be corrected, contact your authorized DoorKing dealer for assistance. Before performing any trouble-shooting, check the following:

1. Have a good VOM meter handy to check voltages and continuity.
2. Have a telephone test set (DoorKing p/n 1800-050 or equivalent) to check the telephone line. Noise on the phone line will cause problems with the entry system.
3. Be sure that the entry system case is properly grounded.
4. Be sure that the telephone wires are twisted.
5. A hum on the system indicates that the phone line or 16 VAC power lines may be grounded. Check to be sure that the phone lines or power lines are not shorted to ground.
6. Check the 16 VAC system power. Be sure that the transformer is properly rated (16 VAC, 20 VA). Keep the wire run from the transformer to the entry system as short as possible. Use 16 or 18 AWG, 600 volt insulated wire only. **The importance of proper power wiring cannot be over stressed!**
7. Isolate the telephone entry system. Disconnect any external devices, such as gate operators, electric strikes, magnetic locks, etc., which may affect the operation of the system.

SYMPTON	POSSIBLE SOLUTION(S)
Cannot get into programming mode.	<ul style="list-style-type: none"> • Wrong master code entered. Start over. • Waiting too long between pushing buttons. Enter information quicker. • Keypad is not plugged into board correctly. Cable points down. • Memory chips are installed upside down.
System emits a long tone and cancels programming.	<ul style="list-style-type: none"> • Waiting too long between pushing buttons. • Forgetting to press * first when programming.
Keypad is dead.	<ul style="list-style-type: none"> • No power. Check for 16 VAC input power. • Check that the keypad is properly connected to the circuit board. The cable on the plug points down when connected to the circuit board.
Buzz or noise on the phone line.	<ul style="list-style-type: none"> • Disconnect the phone line from the system and check it with a handset. If line is noisy, problem is with the phone line and not the entry system. • Check for any shorts to ground behind the circuit board. • Check for pinched wires near the door hinge. • Check for 16-volt power shorted to ground. • Check for phone line shorted to ground. • Check that phone wires are twisted. • Check that the proper type of phone wire was used for an outdoor and / or underground application. • Check that all wires, speaker, keypad, etc. are isolated from ground. • Check that the cabinet is properly grounded. Be sure that case ground (terminal 3) is not used as a low voltage common. • Check for excessive voltage drop on 16 VAC power.
Ringing or howling from the speaker.	<ul style="list-style-type: none"> • Feedback improperly adjusted (4.2). • Volume is set too high (4.1).
After dial out, dial tone is heard on the speaker.	<ul style="list-style-type: none"> • Phone line is a rotary-dial line. Have the phone company change it to a touch-tone line.
Door strike locks on.	<ul style="list-style-type: none"> • Excessive voltage-drop on 16 VAC line. • Using a transformer with too low VA rating. • Relay strike time programmed too long (3.1.3).
Door strike or gate operator holds open.	<ul style="list-style-type: none"> • Auto relay time zone enabled. Turn auto relay feature off or reprogram the time zone (5.2.5). • System was given a hold open command. Call the system and press the tone deactivate number (5.2.2).
Entry system will not answer when called.	<ul style="list-style-type: none"> • Ring pin is not installed (4.6). • Number of rings to answer is set to high. Reprogram (3.1.8). • Bad phone line or insufficient ring voltage.
Rotary dial 9 will not activate relay.	<ul style="list-style-type: none"> • Adjust click sensitivity (4.3).
Touch-tone 9 will not activate relay.	<ul style="list-style-type: none"> • Re-program tone-open number to 9 (3.1.5). • If resident phone emits a short pulse rather than a long tone, press 9 twice in rapid succession 99. • Try another phone that is known to work. • Lower speaker volume (4.1) and re-adjust feedback (4.2).
Relay activates but gate operator will not open.	<ul style="list-style-type: none"> • Re-program relay strike time for a longer period (3.1.3). • Check wiring to gate operator. • Check gate operator.
Postal switch will not activate relay.	<ul style="list-style-type: none"> • Be sure that the wire-tie has been clipped off the postal switch. • Be sure that the relay has been programmed for postal switch input (3.1.6).
Switch 2 input will not activate relay.	<ul style="list-style-type: none"> • Reprogram switch input 2 to activate relay (3.1.6).

SYMPTON	POSSIBLE SOLUTION(S)
Four-digit entry codes will not work.	<ul style="list-style-type: none"> • Forgetting to press # first. • Entry code is time zone restricted. Reprogram time zone or turn time zone off (5.2.4). • Entry code attempted was a flash code that is no longer valid.
Five-digit entry codes will not work.	<ul style="list-style-type: none"> • Forgetting to press ## first. • Entry code is time zone restricted. Reprogram time zone or turn time zone off (5.2.4).
Entry codes will not activate relay 1.	<ul style="list-style-type: none"> • Programmed entry codes are greater than the divide number. Reprogram divide number or program entry codes less than the divide number.
Entry codes will not activate relay 2.	<ul style="list-style-type: none"> • Programmed entry codes are less than or equal to the divide number. Reprogram divide number or program entry codes greater than the divide number
System emits a beep every 30 seconds.	<ul style="list-style-type: none"> • Master code switch is in the ON position.
LCD is unreadable (1802, 1803, 1810 units only).	<ul style="list-style-type: none"> • Adjust contrast.

5.3 ACCESSORIES

Surface Trim Ring	Use to recess surface mount 1803 or 1810 units into a wall or column. P/N 1803-150.
Flush Kit	Use to install flush style 1803 or 1810 units into a wall or column. Kit includes rough in back box and trim ring. P/N 1814-165 comes with stainless steel trim ring. P/N 1814-166 comes with gold plated trim ring.
Flush Ring	Use to surface mount a flush style 1803 or 1810 unit. P/N 1814-152.
Stainless Steel Case	Replaces the black steel surface mount case on the 1803 and 1810 units with a stainless steel case. P/N 1810-102.
Surge Suppressers	High voltage (120 V) suppresser: P/N 1878-076. Phone line suppresser: P/N 1878-077. Low voltage (28 V) suppresser: P/N 1878-078.
Mounting Post	Standard gooseneck mounting post: P/N 1200-045. Standard gooseneck mounting post – long: P/N 1200-046 Heavy-duty Architectural Style mounting post: P/N 1200-037. Heavy-duty Architectural Style mounting post – Long: P/N 1200-038.
Telephone Test Set	Includes clips, cord and carrying case. P/N 1800-050.
Battery	12 volt .8 amp hour gel cell provides stand by power during power interruptions. P/N 1801-008.

5.4 LOG TABLES

Complete the information in the tables on the following pages to maintain a record of the information that has been programmed into the telephone entry system if the system. Make copies of the resident log sheet so that you have enough to complete a listing of all residents and data.

MASTER CODE			

RELAY STRIKE TIME	
RELAY 1	RELAY 2

TONE OPEN NUMBERS RELAY 1	
Momentary	
Continuous	
Release	
Hold 1 Hour	

TONE OPEN NUMBERS RELAY 2	
Momentary	
Continuous	
Release	
Hold 1 Hour	

AREA CODES									
1	2	3	4	5	6	7	8	9	0

4-DIGIT ENTRY CODE TIME ZONE	
Begin Time	
End Time	
Days of Week	
Lower Boundary	
Upper Boundary	

5-DIGIT ENTRY CODE TIME ZONE	
Begin Time	
End Time	
Days of Week	
Lower Boundary	
Upper Boundary	

RELAY AUTO ACTIVATE TIME ZONES				
	ZONE 1	ZONE 2	ZONE 3	ZONE 4
Begin Time				
End Time				
Days of Week				

Resident Instruction Sheet



Your building / community has been equipped with a DoorKing Telephone Entry System that will provide communication for your guest from the lobby door / gated entrance to your home by use of the local telephone network. If you have any questions regarding the use or operation of this system, please see your system administrator (building manager / HOA representative) or call

Guest Communication

Your name (or apartment number) and telephone number have been programmed into the telephone entry system under a specific DIRECTORY CODE. This directory code can be from 1 to 4 digits long depending on the needs of the application. When a guest comes to visit you, they will look your name up in a directory. Next to your name will be listed your DIRECTORY CODE. When your guest enters this code on the system keypad, the system will place a call to your home. If your guest already knows your directory code, they can simply enter the code on the keypad without having to look up your name.

Granting or Denying Access

Once you have answered the phone call and you have identified your guest, you have the choice to either grant access or deny access to your guest.

To grant access to your guest, press _____ on your touch-tone telephone. The telephone entry system will respond with a confirmation tone indicating that the door or gate is opening and will automatically disconnect itself. Some newer telephones emit a very short duration tone when the number is pressed. If your telephone does this, you may have to press the open number twice in rapid succession to open the door or gate.

To deny access to your guest, press the # key.

Rotary Phone Only. If you have a rotary dial phone, dial 9 to grant access. To deny access, hang up.

Call Waiting

If you are on the telephone when a guest tries to contact you from the telephone entry system, they will hear a busy signal and will have to wait for you to end your call before they can contact you. To eliminate this problem, you can order call waiting from your local telephone company.

Privacy

If you do not want your name and/or apartment number listed in the electronic directory, inform the system administrator of this. Your telephone number can be stored in the system without your name being displayed on the directory. If you choose this option, you will need to inform your guest of your directory code, otherwise they will have no method of contacting you from the entry of your building / community through the telephone entry system.

Access Code

Your system may be equipped with an access code that will allow you to open the door / gate by entering this code on the system keypad. Your system administrator will advise you of your access code if this option is available. To use the access code, first press the # key, and then enter the four digit code.

System Administrator - Fill in the blanks above and copy this instruction sheet for your residents.