

# AMERICAN

SPRING AND HARDWARE

## INSTRUCTIONS FOR INSTALLING JAMB TYPE HARDWARE FOR ONE-PIECE RESIDENTIAL OVERHEAD GARAGE DOORS

Please read the following instructions carefully before proceeding, and follow them exactly. We urge you to remember that you are working with a door that may weigh up to 350 lbs. and recommend you exercise care and common sense when installing your garage door.

### The Following Cautionary Notes are Important:

1. DO NOT LIFT THE DOOR BY YOURSELF. Get help to make this safer and easier.
2. When the door is open (step 8a), make sure it is supported securely with a 2 x 4 board nailed in place.
3. Attach springs only when door is open and DO NOT CLOSE DOOR UNTIL SPRINGS ARE SECURELY FASTENED(step 8b)
4. If you require additional assistance, call 1-800-404-9347 or Contact a licensed garage door installer located in your local yellow pages under garage doors.

## STEP 4 LOCATE AND DRILL TOP MOUNTING HOLE AND SPRING ANCHOR HOLE

**NOTE:** Measurements given are for a standard installation where the back of the door, where the door angle mounts, is flush with the jamb. It is not recommended that a replacement set of hardware be installed in the existing jamb holes unless at least one of the following is done:

- a. Use through bolts instead of lag screws.
- b. Replace existing jambs.

Measure down 20" plus the thickness of door (Step 3) starting from the bottom of the header down the jamb to locate your top mounting hole. From the top mounting hole measure 54" down the jamb to locate the **spring anchor hole**. Repeat on other side. Then drill 1/4" pilot holes at each of these locations.

Nail rubber bumpers to bottom of header using pallet nails. Locate the bumpers approximately 10" from the jambs.

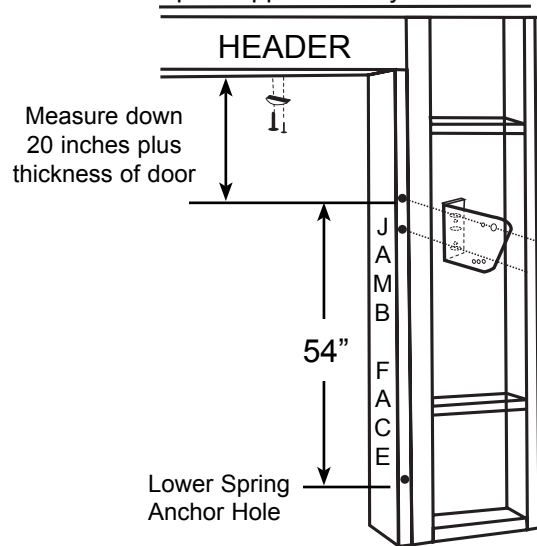

## STEP 1 OVERHEAD CLEARANCE

Measure from the bottom of the header upwards towards the ceiling and back into the garage from the inside of the header which must be free from obstructions. See illustration below.

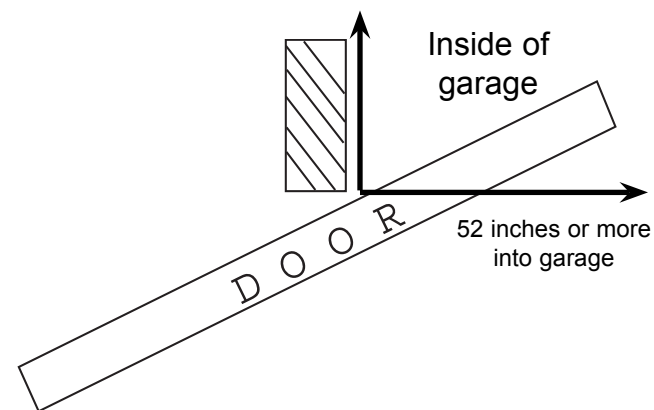

## STEP 5 FASTEN BASIC FRAMES TO JAMBS

Attach left or right side **basic frame** to the jamb by aligning the top slotted hole of the **master plate** with the pre-drilled top mounting hole on the jamb edge. Nail in place using a **duplex nail** (double headed nail) through the small hole under the top slotted hole in the master plate. Repeat on the other side. Next, locate and drill a 1/4" pilot hole through the lower slotted hole in the master plate on both jambs. Then, using the large 3/8 x 3-3/4" **lag screws** with 3/8" **washers** assembled, secure the master plates to the jambs. For best results, mount master plates flush with jamb face.

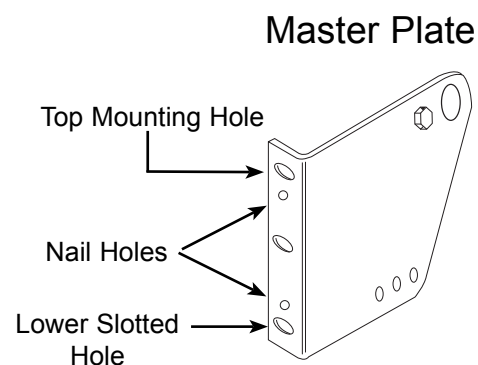

## STEP 2 OVERHEAD ADJUSTMENT HOLE SETTING

Adjustments, for overhead clearance, to hardware set should be made before installing. Your set is preset for 5" or more (hole 1) of overhead clearance which will work in most installations. If you have less than 5" of overhead clearance see drawing below for overhead adjustment hole setting.

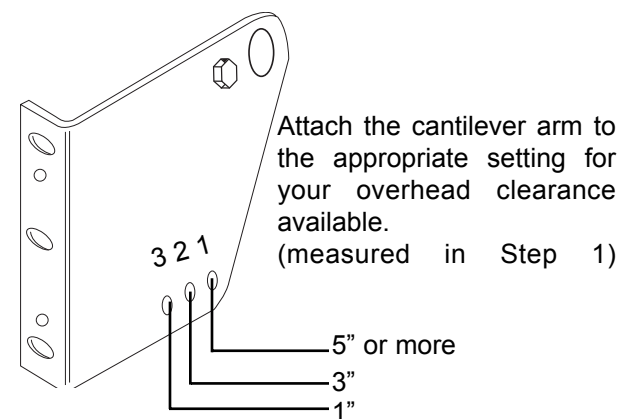

## STEP 6 FASTEN SPRING ANCHORS TO JAMBS

Using 3/8" x 3-3/4" lag screws with 3/8" washers, fasten spring anchor assemblies to jambs by inserting lag screw through the bottom link of the chain and into pre-drilled pilot hole. Tighten securely.

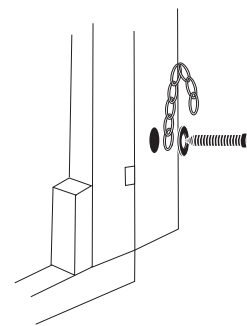

## STEP 7 ALIGNING AND FASTENING DOOR ANGLE

Place door in opening and shim up 3/8" off the floor. Center the door in the opening. Door should have 3/8" gap on each side. Make sure top of door is against the header. Loosen **carriage bolts** on **cantilever arms**. Now move **door angle** into position flat against the door. Drill 3 holes for each door angle, one at each end of the door angle and one near the center (use 3/16" drill bit for these pilot holes). Attach the door angles to the door using 5/16" x 1-1/2" lag screws, then tighten the carriage bolts on the cantilever arms again. While the door is still down, place the door stops between the door and jamb marking the extension of the door stop past the jamb. Do the same for the other side. For a metal door bolt door angle to door with 5/16" x 3/4 hex head bolts and nuts.

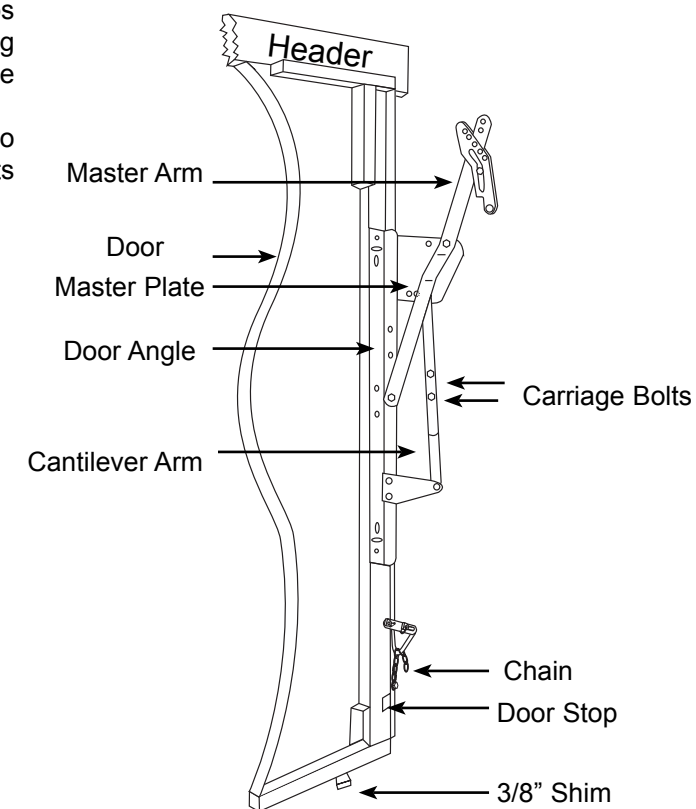

## STEP 3 MEASURING DOOR THICKNESS

Measure from front of door to back of door where door angle mounts including exterior panel. See illustration below.

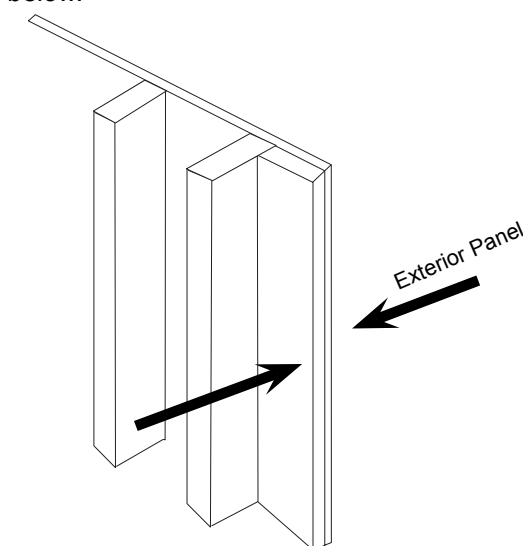

Select the appropriate spring installation for your hardware setup.

**STEP 8A**

Make sure hardware is securely fastened to the door and jambs by checking that all bolts nuts and lags are in place and securely tightened. Raise and prop door in the open position with a 2" x 4" wood member at the bottom center of the door and secure with nails (see illustration below).

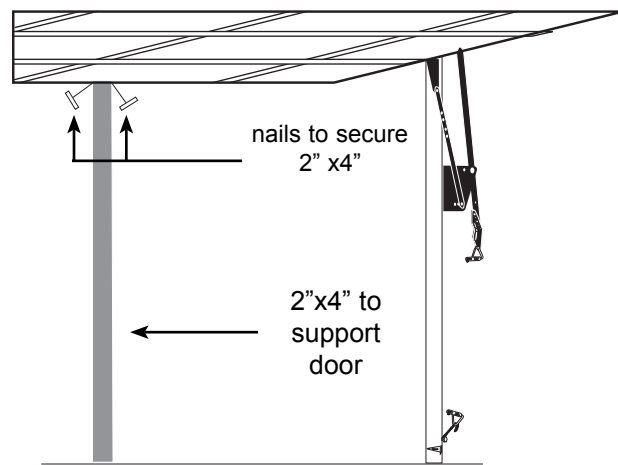

**Step 1. SINGLE SPRING INSTALLATION**

**"SL" Installation**

**A.** Install hook at end of spring into chain at bottom of door jamb. Attach Spanner Plate with 1/4" x 5/8" bolt & nut on hook.

**B.** Stretch spring (Max. 2") and hook over lower bushing on kicker, as shown. If hooks don't line up turn spring in the direction it turns easiest, until lined up.

**C.** Attach top spanner plate, nut, and bolt

**D.** Repeat on other side of door.

**Step 2. DOUBLE SPRING INSTALLATION**

**A.** Install hooks of two springs into chain at bottom of door jamb. Bolt hooks together with 1/4" x 5/8" bolt & nut.

**B.** Stretch springs (Max. 2"), one at a time and hook over lower bushing on kicker, as shown. If hooks don't line up turn in the direction it turns easiest, until lined up.

**C.** Bolt together with bolt and nut.

**D.** Repeat on other side of door.

**Step 1. SINGLE SPRING INSTALLATION**

**"C" hook Installation**

**A.** Install one "C" hook into chain at bottom of door jamb and the other one over the lower bushing in kicker.

**B.** Attach spring to lower "C" hook and install "L" shaped plate over open ends. Secure with "O" ring.

**C.** Stretch spring (2" Max.) and attach to upper "C" hook. Secure with plate and "O" ring.

**D.** Repeat on other side of door.

**Step 2. DOUBLE SPRING INSTALLATION**

**"W" hook Installation**

**A.** Install one "W" hook into chain at bottom of door jamb and the other one over the lower bushing in kicker.

**B.** Attach two springs to lower "W" hook & install plate over the ends. Secure with "O" ring.

**C.** Stretch springs (Max. 2") one at a time and attach to upper "W" hook. Secure with plate and "O" ring.

**D.** Repeat on other side.

If you experience excessive noise while the door is being closed, first secure door in the open position in the same manner as before. Remove spring from upper attachment (at kicker), twist spring(s) 180 degrees in the direction they turn most easily. Resecure springs according to instructions then, only after all parts are secured, remove prop and close door.

**STEP 9 ATTACH DOOR PULL**

Approx. 18" from the bottom, find the middle point of the door and attach the screw eye there. Run the rope through the screw eye and secure with a knot at on end. Run the other end of the rope through handle and secure with knot.

**STEP 10 ATTACHING OUTSIDE HANDLE**

Using the #14 X 1-1/2" screws, attach the **handle** to the outside center of the door about 20" from the bottom. For metal doors use 3/16"x1-1/2" bolt and nut.

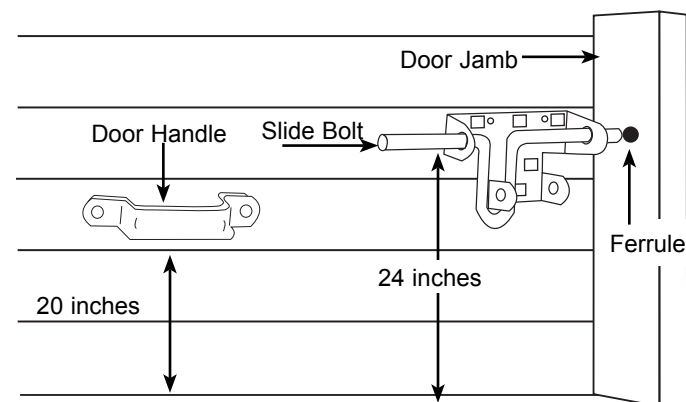

**STEP 11 ATTACH SLIDE BOLT TO THE DOOR**

At a point approx. 24" from the bottom of the door, place the **slide bolt** at the edge of the door so that the end of the bolt (in the open position) is flush with the edge of the door. Mark the center of the holes in the slide bolt frame and drill 1/4" holes through the door. Attach slide bolt with 1/4" carriage bolts (3" or 4" long as provided) using 1/4" washers and nuts on the inside of the door. Next, move the slide bolt until it contacts the jamb, mark this spot. Open the door (always prop it open when working near the door) and drill a 3/4" hole at the point marked on the jamb. Press the **ferrule** into the hole. Your installation is finished at this point but please check and tighten all nuts and lag screws.

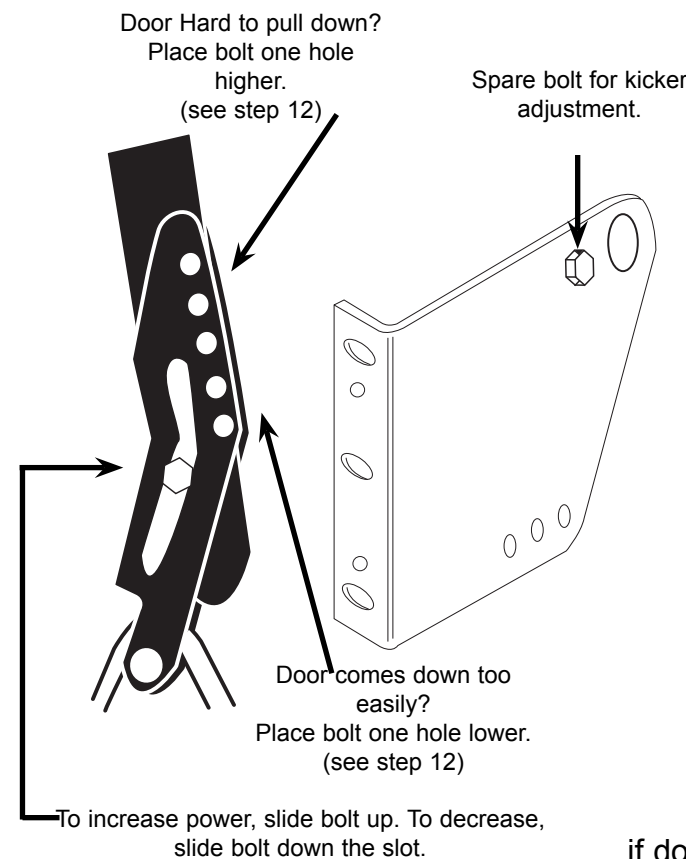

**STEP 12 CHECK BALANCE OF DOOR**

(Door must be in open position for this procedure.)

If door is hard to pull down, or comes down too easily. Remember to always properly secure the door in the open position, before making any adjustments.

**HARD TO PULL DOWN:** Use bolt provided in master plate and place in first empty hole above existing bolt on kicker and secure with nut. Then remove existing bolt and use for other side. When done place spare bolt in master plate.

**DOOR COMES DOWN TOO EASILY:** Use bolt provided in master plate and place in first empty hole below existing bolt on kicker and secure with nut. Then remove existing bolt and use for other side. When done place spare bolt in master plate. See illustration at left.

if door is hard to pull down remove shoulder bolt from master plate and insert it into next available hole hole in above bolt already in kicker.

**LIMITED WARRANTY**

American Spring warrants this product to be free of defects in material or workmanship for a period of one year after date of purchase. We agree to repair or replace, at our option, any part or parts which fail in service during the one year period, without charge for parts or labor.

Any failure due to defects in material or workmanship should be reported promptly to your dealer with full information as to type of failure and date of purchase. Do NOT send hardware directly to American Spring prior to our authorization IN WRITING, as we will not accept unauthorized shipments to our plant. This could result in freight charges both to and from our plant which you may have to pay.

**NOTICE-** Damages resulting from negligence, modification of the product in the field, or accident, ARE NOT covered by this warranty. Hardware and springs can be damaged from excessive stretch of springs, overloading hardware, abuse, or misapplication, and failure from such conditions are not covered by the warranty.

Instructions for installation, care, and safe use of this product are available from your dealer or American Spring. These instructions must be followed. Failure to do so can result in property damage, personal injury, or shortened service life.

Except to the extent prohibited by your state law, all implied warranties made by American Spring in connection with this product, including the warranty of merchantability, are limited in duration to a period of one year from date of original purchase, and no implied warranty shall apply to this product after said period of one year. American Spring assumes no consequential damages sustained in connection with this product. Except as stated above, no other warranties, written or verbal, are authorized to be made by anyone.

American Spring  
Gardena, California 90248