



# EH100-8/EH100-10 Enclosure

## INDOOR, SECURITY RATED, WALL/PEDESTAL MOUNT

### Product Features

- Low Cost
- Indoor Applications
- Aluminum Construction
- Adjustable Camera Mount
- Wall or Pedestal Mounting
- Attractive, Rugged Powder Coat Finish
- Single Tamper-Proof Screw Provides Quick Access and Increased Security



EH100-8 ENCLOSURE

The **EH100 Series** are low cost, light duty, indoor camera enclosures designed for use with various cameras on the market. These enclosures will accommodate fixed focal length lenses or motorized zoom lenses. All-aluminum construction and rugged powder-coated surfaces make the **EH100 Series** a lightweight, attractive camera enclosure for most indoor applications.

The simple, interlocking clamshell design with removable housing provides a fast, simple installation. Once installed, access to camera and lens only requires removal of one tamper-proof screw.

The **EH100 Series** enclosures have an adjustable camera sled that, when installed upside down, can also serve as an elevation block.

A knockout on the base of the enclosure provides the opening for all cabling or a 0.5-inch conduit connection.

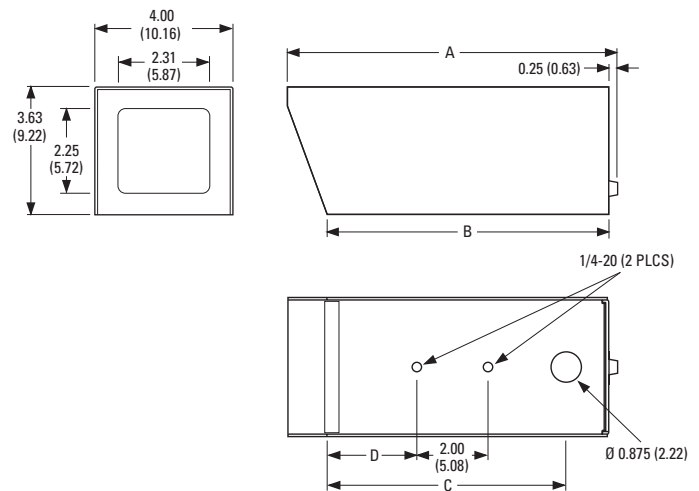

	A	B	C	D
EH100-8	9.25 (23.50)	8.00 (20.32)	6.81 (17.30)	2.59 (6.58)
EH100-10	11.25 (28.58)	10.00 (25.40)	8.81 (22.38)	3.59 (9.12)

NOTE: VALUES IN PARENTHESES ARE CENTIMETERS;  
ALL OTHERS ARE INCHES.



# TECHNICAL SPECIFICATIONS

## MODELS

EH100-8	Security-rated, indoor enclosure, 7.50-inch (19.05 cm) maximum length for camera, lens, and cable connections
EH100-10	Security-rated, indoor enclosure, 9.50-inch (24.13 cm) maximum length for camera, lens and cable connections

## MECHANICAL

Camera Mounting Maximum Camera and Lens Size	Multiple holes on adjustable camera sled  Accepts camera and lens combinations* (including BNC connector) up to:
EH100-8	2.75" H x 3.50" W x 7.50" L (6.99 x 8.89 x 19.05 cm)
EH100-10	2.75" H x 3.50" W x 9.50" L (6.99 x 8.89 x 24.13 cm)
Viewing Window	0.1875-inch (4.76 mm) thick Lexan®
Viewing Window Area	2.25" H x 2.31" W (5.72 x 5.87 cm)
Cable Entry	0.875-inch (2.22 cm) diameter knockout; will accept 0.5-inch (1.27 cm) conduit fitting
Security	Tamper-resistant button-head screw (hollow Allen wrench supplied)

\*Assumes lens is fully extended.

## GENERAL

Construction	Aluminum
Finish	Gray polyester powder coat
Environment	Indoor
Unit Weight	
EH100-8	1.35 lb (0.61 kg)
EH100-10	1.51 lb (0.68 kg)
Shipping Weight	
EH100-8	2 lb (0.9 kg)
EH100-10	3 lb (1.35 kg)

## RECOMMENDED MOUNTS

### Ceiling/Pedestal

EM1009U, EM1015U	Medium duty ceiling/pedestal mount; maximum load 40 lb (18.12 kg)
EM3000	Ceiling J-mount; maximum load 20 lb (9.06 kg).

### Wall

EM1450	Light duty wall mount; maximum load 20 lb (9.06 kg)
EM1900U	Medium duty wall mount; maximum load 40 lb (18.12 kg)
EM2400	Light duty (indoor) wall mount; maximum load 20 lb (9.06 kg)



### Pelco Worldwide Headquarters:

3500 Pelco Way, Clovis, California 93612-5699 USA  
**USA & Canada** Tel: (800) 289-9100 • FAX (800) 289-9150  
**International** Tel: (559) 292-1981 • FAX (559) 348-1120  
[www.pelco.com](http://www.pelco.com)

Pelco and the Pelco logo are registered trademarks of Pelco.  
Lexan is a registered trademark of the General Electric Company.  
Specifications subject to change without notice.  
©Copyright 2000, Pelco. All rights reserved.