

L555VDC4P

5~55mm F1.4 – CS-Mount

Compatible with 1/3" & 1/4" Cameras

- Focal Length:** 5~55mm
- Max. Relative Aperture:** 1:1.4
- Iris:** F1.4~Approx. F360
Built-in ND Spot Filter
- Angular Field of View:** 1/3": 53.1° × 40.0° at 5mm
4.8° × 3.6° at 55mm
1/4": 40.0° × 30.0° at 5mm
3.6° × 2.9° at 55mm
- Min. Object Distance (M.O.D.):** 0.3m @5mm (From Front Vertex)
0.8m @55mm (From Front Vertex)
- Optical Back Focal Distance:** 10.97mm (In Air)
- Operation:** Zoom: Manual
Focus: Manual
Iris: IG (Auto-Close System)
- Operation Voltage:** Close to Open: Less than 4V
Open to Close: More than 0.5V
- Operation Temperature:** -10 ~ +50°C (+14 ~ 122° F)
- Filter Size:** None
- Mount:** CS-Mount
(Adjustable Lens Position)
- Size, Approx. Weight:** 42 × 48 × 64mm (w/h/d), 100g
(Approx. 1.7 × 1.9 × 2.5in., 3.5oz.)

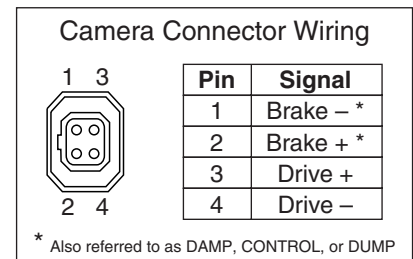
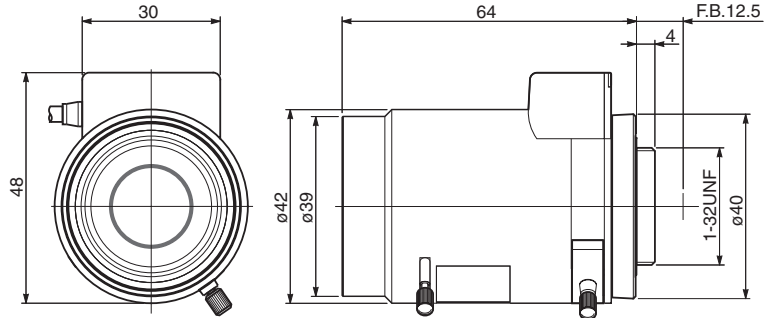

L555VDC4PIR

DAY NIGHT IR

5~55mm F1.4 – CS-Mount

Compatible with 1/3" & 1/4" Cameras

- Focal Length:** 5~55mm
- Max. Relative Aperture:** 1:1.4
- Iris:** F1.4~Approx. F360
Built-in ND Spot Filter
- Angular Field of View:** 1/3": 53.1° × 40.0° at 5mm
4.8° × 3.6° at 55mm
1/4": 40.0° × 30.0° at 5mm
3.6° × 2.9° at 55mm
- Min. Object Distance (M.O.D.):** 0.3m @5mm (From Front Vertex)
0.8m @55mm (From Front Vertex)
- Optical Back Focal Distance:** 11.47mm (In Air)
- Operation:** Zoom: Manual
Focus: Manual
Iris: IG (Auto-Close System)
- Operation Voltage:** Close to Open: Less than 4V
Open to Close: More than 0.5V
- Operation Temperature:** -10 ~ +50°C (+14 ~ 122° F)
- Filter Size:** None
- Mount:** CS-Mount
(Adjustable Lens Position)
- Size, Approx. Weight:** 42 × 48 × 64mm (w/h/d), 100g
(Approx. 1.7 × 1.9 × 2.5in., 3.5oz.)

