

## APCP-1700 POOL COVER PUMP

### EN ENGLISH

This instruction sheet provides you with the information required to safely own and operate your product. Retain these instructions for future reference.

The product you have purchased is of the highest quality workmanship and material, and has been engineered to give you long and reliable service. This product has been carefully tested, inspected, and packaged to ensure safe delivery and operation. Please examine your item(s) carefully to ensure that no damage occurred during shipment. If damage has occurred, please contact the place of purchase. They will assist you in replacement or repair, if required.

**READ THESE INSTRUCTIONS CAREFULLY BEFORE ATTEMPTING TO INSTALL, OPERATE, OR SERVICE YOUR PRODUCT. KNOW THE PRODUCT'S APPLICATION, LIMITATIONS, AND POTENTIAL HAZARDS. PROTECT YOURSELF AND OTHERS BY OBSERVING ALL SAFETY INFORMATION. FAILURE TO COMPLY WITH THESE INSTRUCTIONS COULD RESULT IN PERSONAL INJURY AND/OR PROPERTY DAMAGE!**

### SAFETY GUIDELINES



**WARNING:** To reduce the risk of injury, do not permit children to use this product unless they are closely supervised at all times.

**WARNING:** Risk of electric shock. Connect only to a grounding type receptacle protected by a ground-fault circuit interrupter (GFCI). Contact a qualified electrician if you cannot verify that the receptacle is protected by a GFCI.

**WARNING:** Do not bury cord. Locate cord to minimize damage from lawn mowers, hedge trimmers, and other equipment.

**WARNING:** To reduce the risk of electric shock, replace damaged cord immediately. Contact the manufacturer for replacement of the power cord.

**WARNING:** To reduce the risk of electric shock, do not use extension cord to connect pump to electric supply; provide a properly located outlet.

Never pump chemicals or corrosive liquids with this pump. This could damage the integrity of the enclosure and cause an electrical short. This pump has been evaluated for use with water only.

Never pump gasoline or other low flash point fluids with this pump. Explosion or fire could result. This pump has been evaluated for use with water only.

Do not run this pump dry. Running this pump without water may damage the integrity of the enclosures and cause electrical short.

If service is required, proceed carefully. The pump and surrounding areas may be covered with water. Never plug or unplug the device while standing in wet or damp surfaces. If necessary, remove power at the breaker panel or have certified electrician remove power before attempting to service. Serious or fatal shocks could result if proper procedures are not followed. Disconnect the power at the main electrical service box by switching the appropriate circuit breaker or removing fuse. In applications where screw type fuses are used, remove only the one hand while other hand or torso

is free from contact with anything. Do not stand in water or do not touch any other conductive surfaces.

Icy conditions can cause unnecessary wear on pump. When these conditions exist it is recommended, but not required, to remove the pump from the pool cover. Alternatively, if pump is left installed during these conditions, ensure power cord remains connected to a 115 VAC source.

PUMP SPECIFICATIONS								
			GALLONS PER HOUR					
VOLTS	AMPS	WATTS	1'	5'	10'	15'	20'	21.5'
115	2.2	270	1700	1500	1150	700	200	0

### CAPACITY SIZING INFORMATION

The 1700 GPH performance was obtained through a 1 inch I.D. tube, with friction losses neglected. Using a 3/4" garden hose 50 foot long reduces this performance to approximately 500 gallons per hour due to friction losses in the hose. If your area frequently has heavy rainfalls, (1" - 2" per hour), it may be necessary to use 1" tubing. This should be available in most pool supply stores.

The number of gallons of water that your pool will collect in a rainfall of one inch per hour can be computed as follows: Cover overall length (ft.) x cover overall width (ft.) x .6234 = gallons per hour.  
**NOTE:** This is cover dimension, and not pool dimension.

Examples:

- A 16' x 32' pool cover would collect 319 gallons (16 x 32 x .6234 = 319) in 1 hour, in 1" per hour rain.
- A 20' x 40' pool cover would collect 499 gallons (20 x 40 x .6234 = 499) in 1 hour, in 1" per hour rain.

### INSTALLATION



1. Verify that the electrical outlet to be used meets the requirements of the National Electrical Code (NEC), as well as local electrical codes including grounding and GFCI protection. Also verify that the outlet is properly sized and located for this pump. Your installation may require a certified electrician or plumber. See the ELECTRICAL CONNECTIONS section.
2. If necessary, check your plumbing codes to verify that final installation will be in compliance with their requirements.
3. Connect a garden hose to the hose adaptor, or use a 1" nipple and flexible PVC tubing secured to the pump discharge.  
**NOTE:** If flexible 1" PVC tubing is used, secure the free end so that it cannot blow back onto the pool cover in high wind.
4. Gently lower the pump onto the pool cover by holding onto the garden hose. Do not pull the power cord plug onto the pool cover. The pump is equipped with an eyelet opposite the discharge for attaching a positioning rope (not included). Use rope and a garden hose to position pump onto the pool cover. Two people should position the pump, with the first person holding the electrical cord plug and the second person positioning the pump at the desired location on the pool cover. The pump is equipped with an 18 AWG, 25-foot power cord with a 3-prong ,grounding-type plug.
5. Once the pump is in position and proper electrical connections have been made, it is ready for testing. See the ELECTRICAL CONNECTIONS section.

During the rainy season, check daily to ensure that the pump is functioning properly. During high winds or excessive movement of the pool cover, be certain that the power supply cord has not been pulled onto the cover, and that the pump is still upright with the discharge hose properly positioned. If you plan to be away from your pool for an extended period, have someone periodically check your pump to verify that everything is functioning properly. Be sure to

review the SAFETY GUIDELINES and ELECTRICAL CONNECTIONS sections with them.

### OPERATION



The water level switch is activated by a float mechanism. This is caused by water rising around the float with the pump resting upright. This switch relies upon buoyancy force of the float to activate. The switch should cause pump to come on when the water level is approximately 2"-3" deep. Pump should remain running until the water level is approximately .50"-1.50" deep. **NOTE:** Temperatures near freezing may cause the ON level to go as high as 4", and the OFF to be as high as 2".

### ELECTRICAL CONNECTIONS



1. Your pump is supplied with a 3-prong electrical plug. The third prong grounds the pump to prevent possible electrical shock hazard. Do not remove the third prong from the plug.
2. A separate branch electrical circuit is recommended. The electrical power required is 5 amp at 115 VAC.
3. Be sure that electrical connection cannot be reached by rising water. Under no circumstances should the connection be located where it may become flooded or submerged by water.
4. Test the pump after all electrical connections have been made. Run water into area where pump is to be placed. Do not attempt to run the pump without water; this could cause damage to the pump. Fill the area to a normal ON level and allow the pump to remove water to a normal OFF level.

**WARNING:** Always disconnect the electrical power before touching the pump, discharge, or electrical plug when water is present in the area. Failure to do so can result in serious bodily injury and/

or property damage. Always connect the pump to a grounded receptacle. See SAFETY GUIDELINES.

### SERVICE INSTRUCTIONS



**WARNING:** Before servicing pump, disconnect it from electrical service, unplug cord, remove fuse, or turn off disconnect box.

The motor housing of the pump is completely sealed and requires no service. Disassembly of the motor housing or alteration of the power cord voids all warranty.

The motor is a continuous duty type with an automatic thermal overload protector device.

The pump can run against a restricted discharge without damage to the pump.

Keep pump clean and in a well maintained condition at all times. Pump should be thoroughly cleaned for summer storage.

If float becomes stuck, remove the float access cap on the bottom of the pump. Remove cap by turning towards the "OPEN" arrow as indicated on the cap. Clean as needed, then reinstall access cap.

This pump has an internal vent hole to prevent an air-lock condition. Periodically the vent hole can become obstructed and will require cleaning according to Figure 1 and the following steps:

1. Disconnect the pump from electrical service.
2. Loosen and remove the five screws from the outer blue cover. (**NOTE:** Only four of the five screws are shown in Figure 1.)
3. Remove the outer cover.
4. Clean debris from the vent hole.
5. Re-install the outer cover and screws.
6. Re-connect the pump to electrical service.

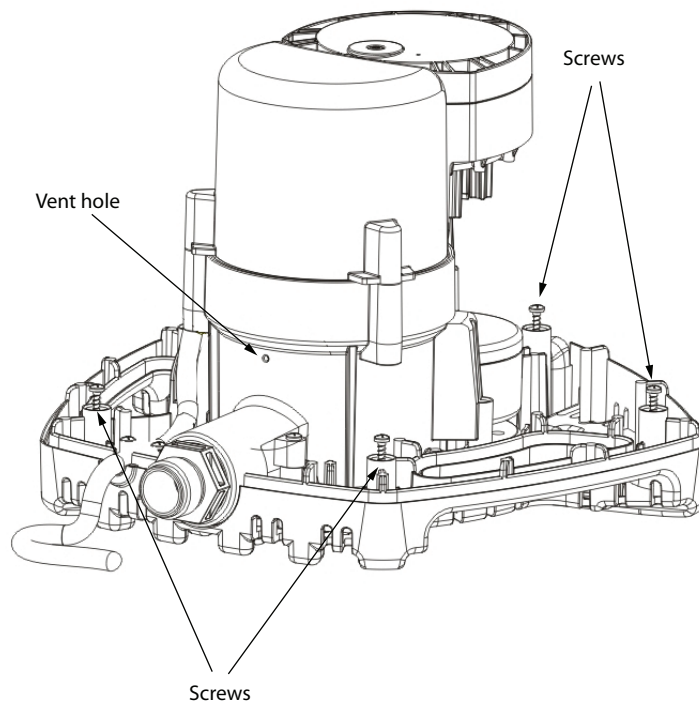
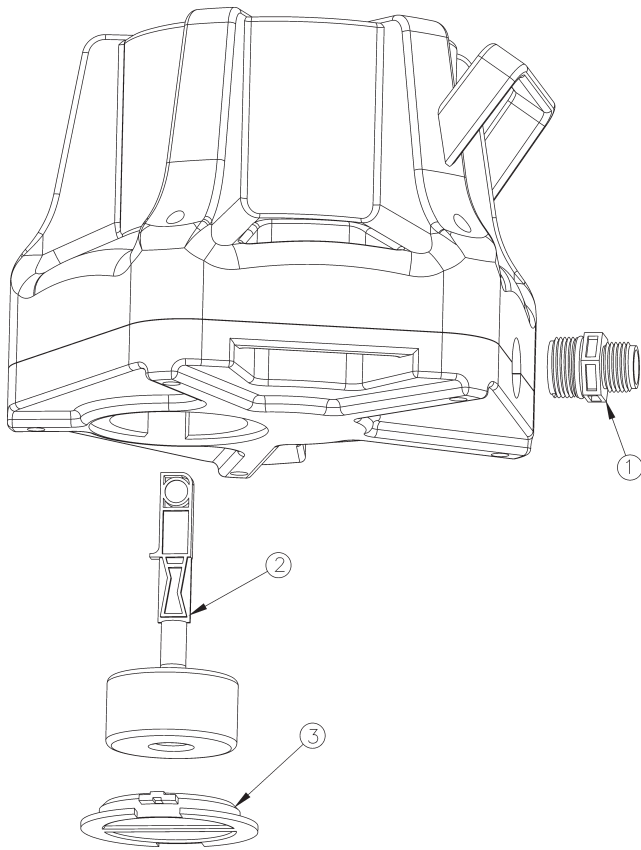

FIGURE 1



**FIGURE 2**

REPLACEMENT PARTS			
Item No.	Part No.	Description	Qty.
1	177343	Garden hose adapter	1
2	177344	Float/stem assembly	1
3	177345	Float access cover	1

**TROUBLESHOOTING INFORMATION**

SYMPTOM	CAUSE	REMEDY
Pump will not shut off.	Stuck float.	Clean area around float.
	Defective switch.	Contact factory.
	Pump is air locked.	Shut power off for approximately 1 minute, then restart. Repeat several times to clear air from pump.
	Liquid inflow matches or exceeds pump capacity.	Larger pump required, or multiple pumps. See capacity sizing information.
	Frozen water in discharge hose.	Thaw hose or replace hose.
Pump runs but will not discharge liquid.	Lift too high for pump.	Check pump specifications table.
	Inlet to impeller plugged.	Pull pump and clean.
	Pump is air locked.	Shut power off for approximately 1 minute, then restart the pump. Repeat several times to clear air from the pump. If this does not resolve the problem, the vent hole might be blocked. Clean the hole according the SERVICE INSTRUCTIONS section.
	Frozen water in discharge hose.	Thaw hose or change out.
Pump does not deliver rated capacity.	Lift too high for pump.	Check rated pump performance.
	Low voltage, speed too slow.	Check for proper supply voltage, ensuring that it corresponds to nameplate voltage.
	Impeller or discharge pipe is clogged.	Pull pump and clean. Check pipe for scale or corrosion.
Pump cycles continually.	No check valve in long discharge pipe allowing liquid to drain back onto cover.	Install a check valve in discharge line.
	Check valve leaking.	Inspect check valve for correct operation.
	Switch failed.	Have pump serviced.
	Volute clogged.	Clean screen and basket.
	Switch float stuck.	Remove access screen and clean debris from float.
	Motor failure.	Have pump serviced.
	Thermal protector activated.	Allow pump to cool.
	GFCI device activated.	Inspect all electrical connections and reset GFCI.

**LIMITED WARRANTY**

Your Little Giant product is guaranteed to be in perfect condition when it leaves our Factory. It is warranted against defective materials and workmanship for a period of 36 months from date of purchase by the user. Any product that should fail for either of the above two reasons and is still within the warranty period will be repaired or replaced at the option of Little Giant as the sole remedy of buyer. For our customers in the CONTINENTAL UNITED STATES: Please return the defective unit, postage paid, to the factory at 301 N. MacArthur, Oklahoma City, OK 73127-6616. All defective product returned under warranty will be fully inspected to determine the cause of failure before warranty is approved.

For our customers located elsewhere; it is not economical, due to duties and freight, to return the pump to the factory for inspection. Please return the defective unit to any authorized distributor or dealer with a brief written explanation of the problem. If there are no apparent signs of customer abuse, unit will be repaired or replaced. If dispute arises over replacement of the pump, the distributor or dealer is to segregate such items and hold for inspection by a representative of Little Giant Pump Company or notify factory with details of the problem for factory disposition and settlement of warranty claim.

**DISCLAIMER:**

THE FOREGOING WARRANTY IS AN EXCLUSIVE WARRANTY IN LIEU OF ANY OTHER EXPRESS WARRANTIES. ANY IMPLIED WARRANTIES (INCLUDING, BUT NOT LIMITED TO ANY IMPLIED WARRANTY OF MERCHANTABILITY OR FITNESS FOR A PARTICULAR PURPOSE) TO THE EXTENT EITHER APPLIES TO A PUMP SHALL BE LIMITED IN DURATION TO THE PERIODS OF THE EXPRESS WARRANTIES GIVEN ABOVE.

Warranty will be **VOID** if any of the following conditions are found:

1. Sealed motor housing opened.
2. Product connected to voltage other than indicated on nameplate.
3. Cord cut off to a length less than three feet.
4. Pump allowed to operate dry (fluid supply cut off).
5. Pump used to circulate anything other than fresh water at approximately room temperature.
6. Product abuse by customer.

Any oral statements about the product made by the seller, the manufacturer, the representatives or any other parties, do not constitute warranties, shall not be relied upon by the user and are not part of the contract for sale. Seller's and manufacturer's only obligation, and buyer's only remedy, shall be the replacement and/or repair by the manufacturer of the product as described above. NEITHER SELLER NOR THE MANUFACTURER SHALL BE LIABLE FOR ANY INJURY, LOSS OR DAMAGE, DIRECT, INCIDENTAL OR CONSEQUENTIAL (INCLUDING, BUT NOT LIMITED TO INCIDENTAL OR CONSEQUENTIAL DAMAGES FOR LOST PROFITS, LOST SALES, INJURY TO PERSON OR PROPERTY, OR ANY OTHER INCIDENTAL OR CONSEQUENTIAL LOSS), ARISING OUT OF THE USE OR THE INABILITY TO USE THE PRODUCT AND THE USER AGREES THAT NO OTHER REMEDY SHALL BE AVAILABLE TO IT. Before using, the user shall determine the suitability of the product for the intended use, and user assumes all risk and liability whatsoever in connection therewith.

Some states and countries do not allow limitations on how long an implied warranty lasts or the exclusion or limitation of incidental or consequential damages, so the above limitations or exclusions may not apply to you. This warranty gives you specific legal rights, and you may also have other rights which vary from state to state and country to country.

The National Electric Code (in the USA) and similar codes in other countries require a Ground Fault Circuit Interrupter (GFCI) to be installed in the branch circuit supplying fountain equipment rated above 15 volts. 115 volt GFCI's (with various cord lengths) are in stock, and we recommend each pump be used with a GFCI.

---

For parts or repair, please contact ..... 1-888-572-9933  
 For technical assistance, please contact ..... 1-888-956-0000

www.LittleGiantPump.com  
 CustomerService-WTS@fele.com

---